

High-quality in-place recycling of asphalt layers

COLD RECYCLERS

W 240 CR(i) | W 380 CR(i)



HIGH-QUALITY IN-PLACE RECYCLING OF ASPHALT LAYERS



Cold In-place Recycling (CIR) and Full Depth Reclamation (FDR): the CR series machines are used as part of a paving train for the economical cold in-place recycling of road pavements in a single pass adding cement, emulsion or foamed bitumen, featuring a mixing capacity of up to 800 t/h.

Traffic lanes are rehabilitated quickly and easily using the compact W 240 CR(i) cold recycler with integrated paving screed.

The powerful W 380 CR(i) rear loader recycles extra wide road pavements across the full width, offering exceptionally high daily performance rates.

Lateral premilling gives the cold recyclers the flexibility needed to rehabilitate road pavements in a single pass even at widths exceeding the machine's working width.

The cold recyclers can also be used as high-performance milling machines or to granulate pavement structures.

WIRTGEN RECYCLERS AND SOIL STABILIZERS

TRACTOR-TOWED STABILIZERS

- > Working width up to 2,500 mm
- > Working depth up to 500 mm

COLD RECYCLERS AND SOIL STABILIZERS (WHEELED CHASSIS)

- > Working width up to 2,400 mm
- > Working depth up to 560 mm

COLD RECYCLERS (CRAWLER UNIT CHASSIS)

- > Working width up to 3,800 mm
- > Working depth up to 350 mm

MOBILE COLD RECYCLING MIXING PLANT

- > Mixing capacity up to 240 t/h

LABORATORY EQUIPMENT

OVERVIEW OF HIGHLIGHTS

Perfectly Equipped

01 Simple Operating Concept

- > Flexible positioning of the main control panels in both directions of operation
- > All machine parameters are displayed on a high-resolution color screen
- > Four large, clearly structured control panels for operation by the ground crew
- > On-board diagnostic system for quick and easy assistance with maintenance procedures
- > Many new automated features enhance ease of operation
- > High-precision **LEVEL PRO** leveling system comprising different sensor models

02 Perfection in Visibility, Comfort and Ergonomic Design

- > Optimized machine geometry ensures perfect visibility
- > High-quality camera system comprising up to seven cameras
- > Clearly structured, adaptable operator's platform including canopy
- > Powerful LED lighting system for night operations
- > Easy start-up and quick modification of the machine to match the specific application



A W 240 CR(i) WITH PAVING SCREED

- > Recycling in a single pass using the W 240 CR(i)
- > VÖGELE paving screed with innovative automatic screed feature adaptable to the rear of the machine
- > **LEVEL PRO** leveling system ensures paving true to grade and slope
- > Material guide plate system at the front collects the milled material from previously performed lateral milling operations to allow variable paving widths
- > Compact machine size and ease of transport

03 Tremendous Performance

- > High-powered, high-torque diesel engine
- > Minimized engine noise emissions allow around-the-clock operations in urban environments
- > Emission standards US Tier 2 (no EU regulation) or strict emission standards EU Stage 5 / US Tier 4f
- > Intelligent engine-machine management system for maximum advance rates
- > All-track drive (ASC) and fourfold full-floating lifting column feature ensure optimum traction
- > Direct mechanical rotor drive ensures high efficiency

04 High-Precision, Reliable Injection Systems

- > Integrated injection systems for water, bitumen emulsion and foamed bitumen
- > **VARIO** injection bar - adjustment of injection pressure via variable nozzle openings
- > Metering panel with screen for reliable operation and easy monitoring of binder metering
- > Electrically heated bitumen system
- > Innovative process water monitoring for the production of foamed bitumen
- > Automatic self-cleaning and flushing feature for high functional reliability of the injection nozzles

05 Effective Cutting and Mixing Technology

- > Perfectly designed milling and mixing unit for both recycling and front-loading operations (milling)
- > Extremely hard-wearing **HT22** quick-change toolholder system
- > Hydraulic rotor rotation device and hydraulic or pneumatic pick ejector drift for quick and easy pick replacement
- > **MCS EXTEND** (Multiple Cutting System) available for working widths of 3.2 m, 3.5 m and 3.8 m



B W 240 CR(i) / W 380 CR(i) WITH REAR-LOADING FEATURE

- > Recycling in a single pass using the W 380 CR(i)
- > High-capacity folding and slewing discharge conveyor with continuously adjustable belt speed
- > Easy handling thanks to the large storage capacity of the paver's material hopper
- > Controlled transfer of excess material into trucks via the discharge conveyor
- > Material guide plate system at the front collects the milled material from previously performed lateral milling operations to allow variable paving widths

COLD RECYCLING WITH INTEGRATED PAVING SCREED

- 01 STREUMASTER binder spreader
- 02 Water tanker truck
- 03 Binder tanker truck

- 04 WIRTGEN cold recycler W 240 CR(i)
- 05 HAMM tandem roller

- 06 HAMM pneumatic-tyred roller

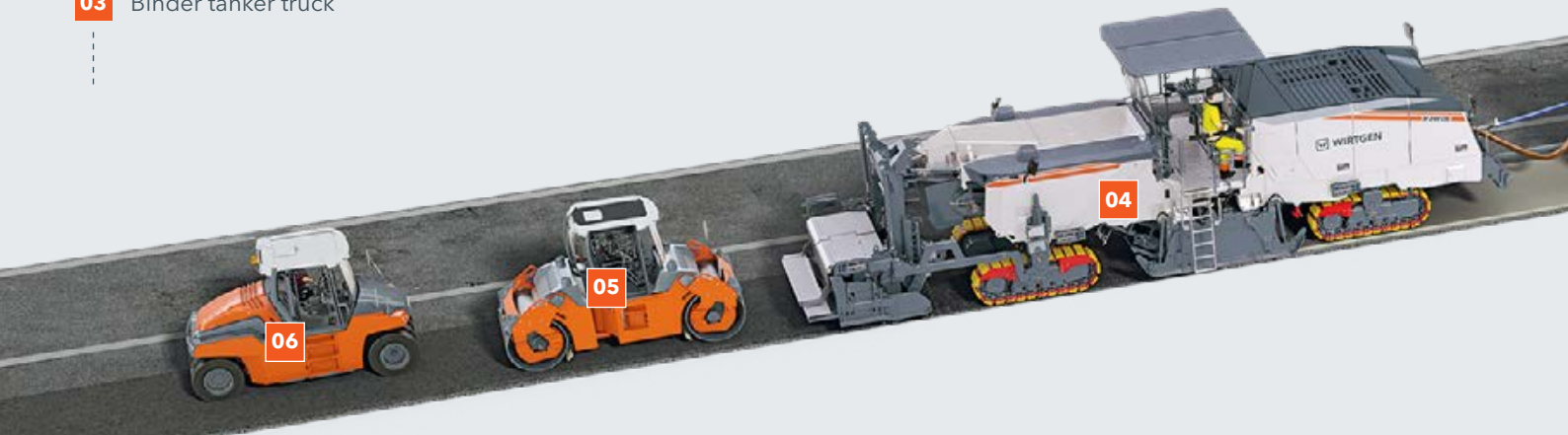

02

Direction of operation

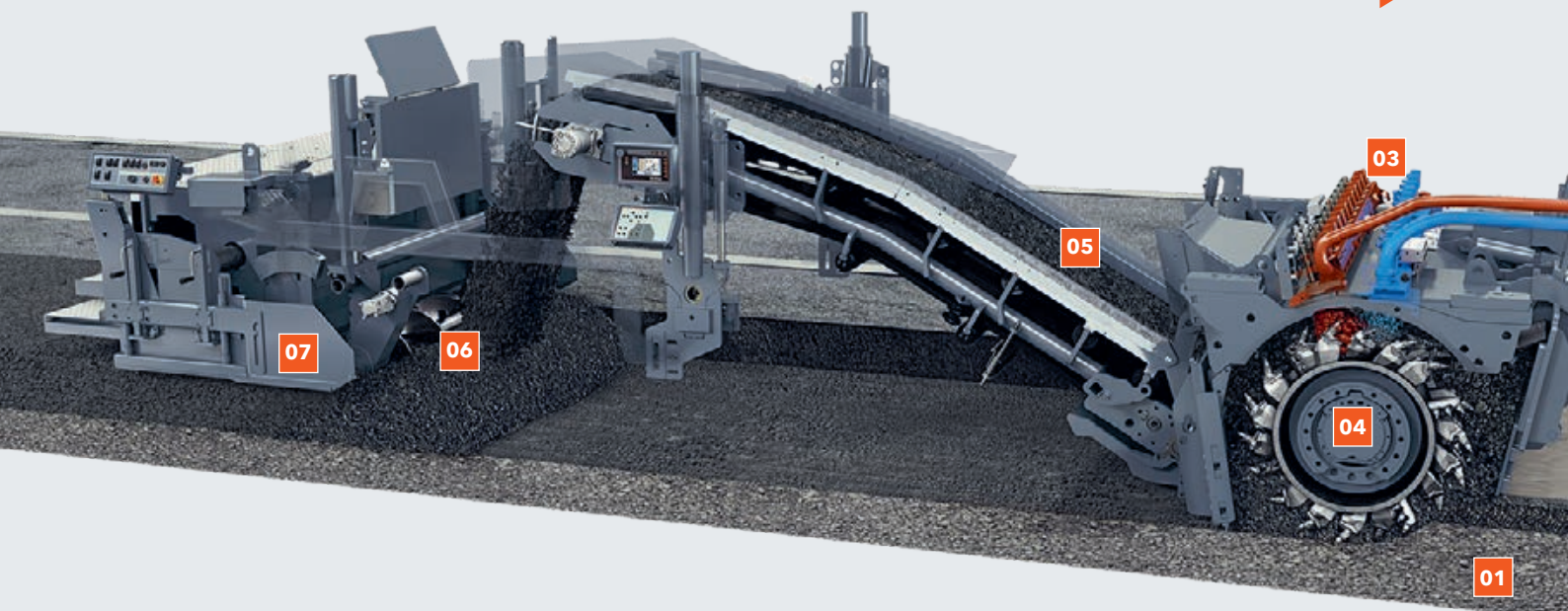

Recycling Train Including the W 240 CR(i)

Where specified, cement is pre-spread by a STREUMASTER binder spreader which is followed by water and binder tanker trucks. The milling and mixing rotor installed in the W 240 CR(i) granulates the asphalt layers. The pre-spread cement is mixed in at the same time while water and bitumen emulsion or foamed bitumen are injected into the mixing

chamber via injection bars. The recycled construction material is transported to the rear of the machine via the primary conveyor and paved true to grade and slope by the VÖGELE paving screed with integrated spreading auger. Final compaction of the material is then effected by HAMM rollers.



Direction of operation



01

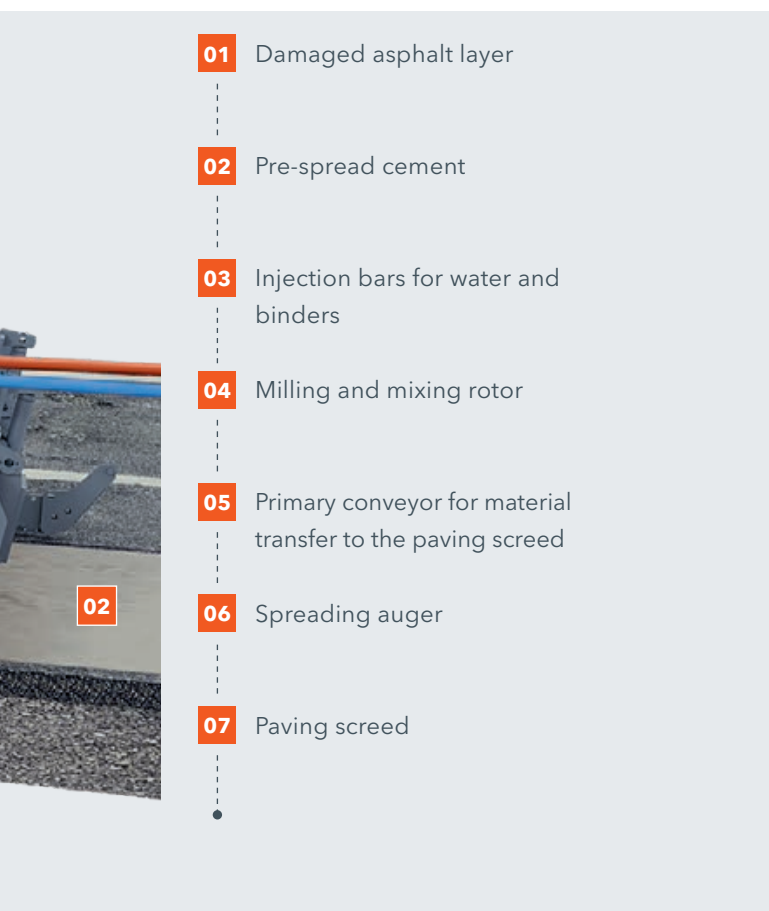

01 Damaged asphalt layer

02 Pre-spread cement

03 Injection bars for water and binders

04 Milling and mixing rotor

05 Primary conveyor for material transfer to the paving screed

06 Spreading auger

07 Paving screed

The robust milling and mixing rotor granulates the damaged asphalt pavement. The granulated material is mixed with injected binders and water in the mixing chamber, thus creating a new homogeneous mix in an in-situ process.

Due to the helical design of the milling and mixing rotor, the recycled mix is conveyed towards the centre and subsequently transported to the paving unit via the primary conveyor. The spreading auger distributes the material evenly ahead of the variable paving screed which then paves it true to grade and slope.

01 Recycling train including the W 240 CR(i).

02 Recycling material with the W 240 CR(i) (down-cut).

COLD RECYCLING WITH INTEGRATED REAR LOADING

- 01** STREUMASTER binder spreader
- 02** Water tanker truck
- 03** Binder tanker truck

- 04** WIRTGEN cold recycler W 380 CR(i)
- 05** VÖGELE asphalt paver

- 06** HAMM tandem roller
- 07** HAMM pneumatic-tyred roller

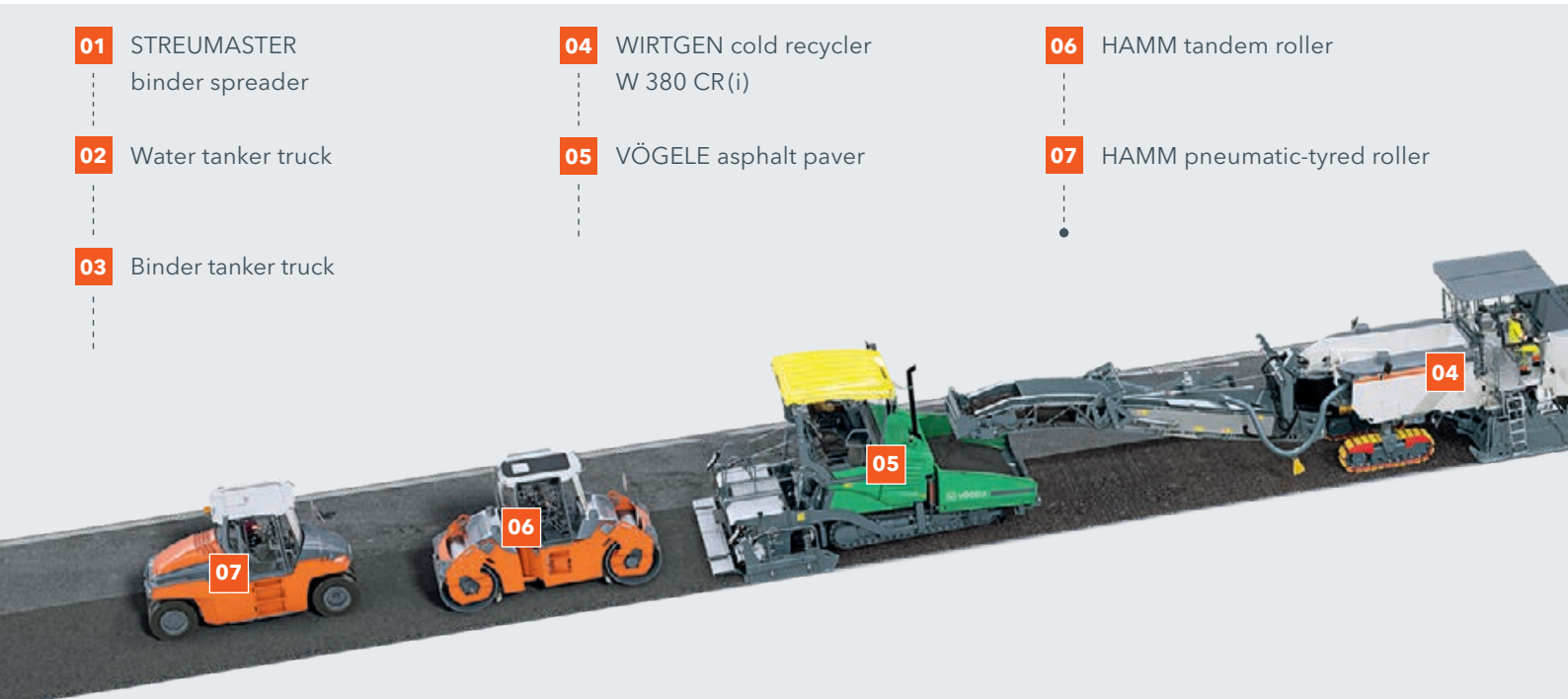

02

Direction of operation

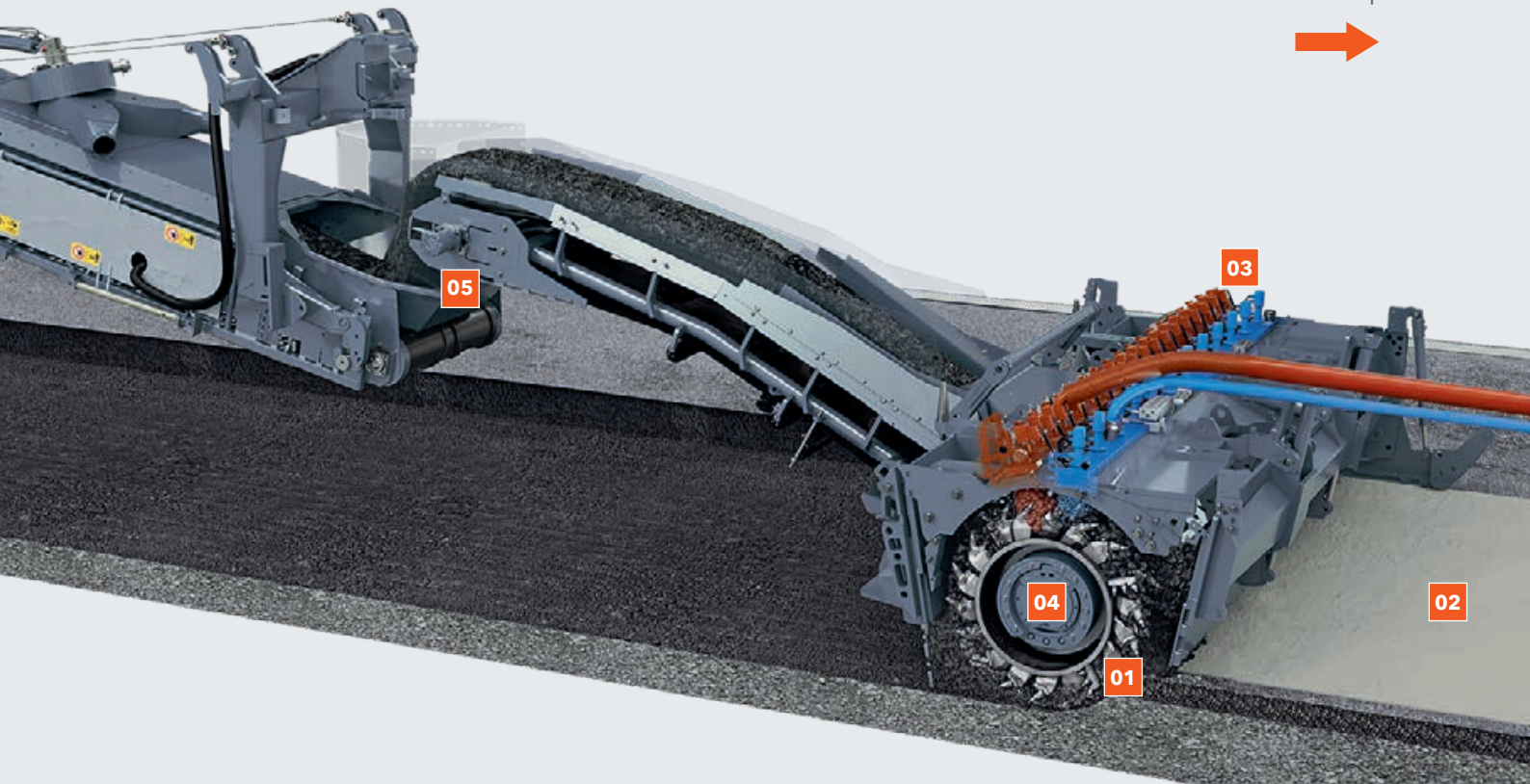

Recycling Train Including the W 380 CR(i)

Where specified, cement is pre-spread by a STREUMASTER binder spreader which is followed by water and binder tanker trucks. The milling and mixing rotor granulates the asphalt layers. The pre-spread cement is mixed in at the same time while water and bitumen emulsion or foamed bitumen are injected into the mixing chamber via injection bars. The recycled con-

struction material is picked up by the conveyor system and transported right into the material hopper of the VÖGELE asphalt paver for placing. Final compaction of the material is then effected by HAMM rollers.



Direction of operation



01 Damaged asphalt layer

02 Pre-spread cement

03 Injection bars for water and binders

04 Milling and mixing rotor

05 Primary conveyor and discharge conveyor for material transfer to the asphalt paver

The robust milling and mixing rotor granulates the damaged asphalt pavement. The granulated material is mixed with injected binders and water in the mixing chamber, thus creating a new homogeneous mix in an in-situ process.

Due to the helical design of the milling and mixing rotor, the recycled mix is conveyed towards the centre and subsequently transported to the material hopper of the asphalt paver via the conveyor system comprising primary and discharge conveyor. The asphalt paver then paves the material true to grade and slope.

01 Recycling train including the W 380 CR(i).

02 Recycling material with the W 380 CR(i) (down-cut)

APPLICATIONS OF THE COLD RECYCLERS

A Example of application using the W 240 CR(i)

Recycling with integrated paving screed (lateral premilling permits variable working widths)



B Example of application using the W 380 CR(i)

Recycling with loading conveyor and paver (lateral premilling permits variable working widths)



C Example of application using the W 240 CR(i) / W 380 CR(i)

Lateral premilling and recycling with loading conveyor and paver



D Example of application using the W 240 CR(i) / W 380 CR(i)

Cold milling with discharge conveyor and truck





SIMPLE OPERATING CONCEPT

Flexible Positioning of the Main Control Panels

Flexible positioning of the two functionally identical, individually adjustable main control panels on the left and right permits the cold recycler to always be operated in line with ergonomic principles, ensuring perfect visibility at the same time. When changing the machine's direction of operation, the control panels are simply mounted on the opposite side of the operator's platform. The machine can also be operated quite easily when standing transverse to the direction of travel.

Display of All Machine Parameters

All important machine and metering parameters can be adjusted and monitored quite easily via the clearly and logically structured control screen.

Four Large Control Panels for the Ground Crew

Four large, clearly structured control consoles enable numerous functions such as adjusting the material guide plates, side plates, rotor plate or machine height to be operated by the ground crew.

On-Board Diagnostic System

The machine's automatic self-diagnostic system autonomously monitors valves, sensors and control components. Numerous clearly visualized pages provide quick and accurate information on the machine's current operating parameters. In addition, the machine offers ready access to all servicing points.

01



Ergonomics for Every Job

Flexibly positionable control panels

Complete Control

Extra panels for operating personnel

Many New Automated Features

Operation of the machine is simplified enormously by a multitude of new automated features such as the alignment of the machine parallel to the pavement surface (PTS), load-controlled conveyor belt speed, or cleaning of the injection systems.

High-Precision LEVEL PRO Leveling System

The tried-and-tested LEVEL PRO leveling system includes control screens for the machine operator and ground crew, as well as a wide variety of different application-specific sensors ensuring precise milling results.



01 The control panels can be adjusted to perfectly meet the different job requirements.

02 The ground crew can easily adjust conveyor settings and the machine's advance rate or monitor metering functions.



PERFECTION IN VISIBILITY, COMFORT AND ERGONOMIC DESIGN

Perfect Visibility

The intelligent geometry of the machine frame provides a perfect view of important areas of the operation regardless of the job to be performed or the machine's working direction. The dual wasp waist, slanting engine cowling and separate viewing channel enable the operator to always keep an eye on both the zero-clearance side and the material loading process.

High-Quality Camera System

The robust camera system comprises up to seven cameras. High-resolution camera images can be simultaneously displayed on different screens. The camera image of the discharge conveyor can, for example, be displayed both on the camera screen and on the metering panel.

Clearly Structured Operator's Platform

The spacious operator's platform, which is equipped with one each stand-up seat left and right, provides ideal ergonomic

conditions for the machine operator to fully focus on his task. In addition, the machine is extremely quiet in operation. The operator's platform can be folded out to offer a workplace even beyond the edge of the machine. Depending on weather conditions, the canopy can additionally be moved to the left or right and extended on either side.

Powerful LED Lighting System

Intelligently arranged, bright LED working lights and LED lighting balloons offer perfect visibility in poor lighting conditions.

Easy Start-Up and Quick Modification

Modifications such as mounting or removing the conveyor or paving screed can be completed within a short period of time. The support arm installed to accommodate the push bar and hoses at the front of the machine additionally facilitates operation during tanker truck changes.



Stress-Free Operating

Large operator's platform

Ideal Overview of Important Working Areas

Practical camera system

- 01** Excellent lighting enables night operations to be completed rapidly and efficiently.
- 02** The operator always has an unobstructed view of the milling edge and discharge conveyor.
- 03** Different camera systems provide a good view of important areas of the operation.



03



Standard camera system comprising one camera:
area in front of the machine



Optional camera system comprising up to seven cameras:
area in front of the machine / front track units / front rotor plate / rear rotor plate / left side of the machine towards the front / paving screed / loading situation

TREMENDOUS PERFORMANCE

High-Torque Diesel Engine

The state-of-the-art diesel engine offers tremendous drive power and a high maximum torque, ensuring fast-paced operation and high production rates even at the maximum milling depth. It permits a wide range of applications at a mixing capacity of up to 800 t/h, making the cold recycler the ideal candidate also for power-sapping operations such as pulverizing hard pavement structures to the specified quality.

Minimized Engine Noise Emissions

Optimized machine settings, effective soundproofing and temperature-controlled fan speed team up to significantly reduce

noise emission levels. Our strict environmental standards thus enable operations to continue around the clock even in residential areas.

Different Exhaust Emission Standards

The engine technology installed in the W 240 CR / W 380 CR complies with the exhaust emission standards of US Tier 2 (no EU regulation) or lower. The W 240 CRi / W 380 CRi complies with the strict specifications of exhaust emission standards EU Stage 5 / US Tier 4f. The engine station of the W 240 CRi / W 380 CRi is additionally equipped with a dual diesel oxidation catalyst, thus dispensing with the need for a urea solution tank.



01

Built to Handle Every Challenge

Powerful engine

Quiet Mover

Focused on low environmental impact

02

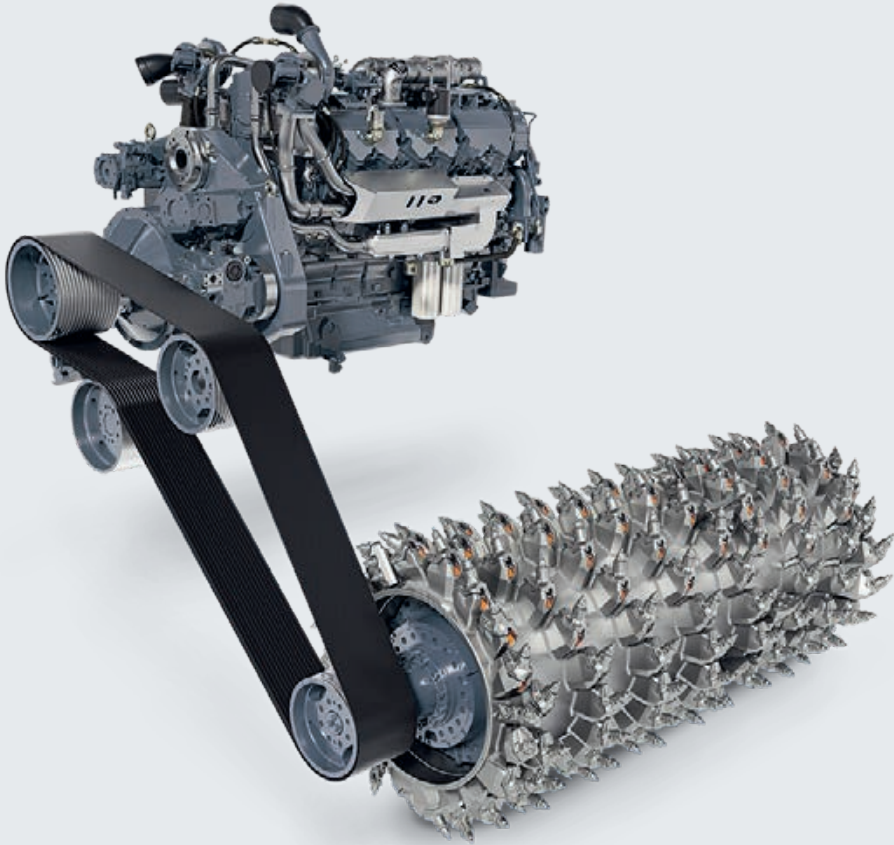

01 Low noise and exhaust emissions, paired with compact machine dimensions, allow operation even in urban environments.

02 The salient features of the cold recycler include three different rotor speeds, high engine power, mechanical rotor drive and speed-controlled fan drive.



TREMENDOUS PERFORMANCE

Intelligent Engine-Machine Management System

The machine's intelligent, fully electronic control system governs not only the interplay of important machine components but also the advance rate of the cold recycler in accordance with the machine and engine load. This relieves the machine operator of a tremendous part of his workload while at the same time improving machine performance. The machine's state-of-the-art technology reduces diesel consumption as well as CO₂ and noise emissions.

All-Track Drive (Asc) and Fourfold Full-Floating Lifting Column Feature

Quick manoeuvring and small turning radii are guaranteed by the machine's smooth hydraulic all-track steering system.

Electronic traction control ensures optimum driving performance regardless of ground conditions. The perfectly balanced fourfold full-floating feature and increased travel of the lifting columns can be relied on to not only quickly level out any ground irregularities but to also facilitate machine loading.

Direct Mechanical Rotor Drive

The mechanical milling and mixing rotor drive permits consistently high performance rates at high efficiency levels. This is of vital importance whenever high mixing performance is required – for example, when mixing the material from previously performed lateral milling operations with the layer yet to be granulated.



01

Lower Carbon Emissions, Higher Performance

Smart machine control

Optimal Traction

All-track steering



02



01 The compact W 240 CRi with integrated screed carrying out high-performance recycling operations on a motorway site.

02 Lateral premilling enables the cold recycler to rehabilitate even wider road surfaces.

HIGH-PRECISION, RELIABLE INJECTION SYSTEMS

Integrated Injection Systems

High-precision, microcontroller-controlled injection systems can be relied on to precisely govern the addition of water, bitumen emulsion or foamed bitumen. Multiple injection bars can be installed and different binders injected simultaneously depending on application requirements.

The hose connections and pumps of the injection systems are located at the front of the machine close to the tanker trucks to allow quick truck changes. Low suction points ensure good supply to the pumps and easy venting. Feed hoses installed in the machine frame provide a clear view of the process.

Adjustable Injection Pressure

The **VARIO** injection bars for foamed bitumen, emulsion and water feature nozzles with an adjustable cross-section to allow flexible adjustment of the spraying pressure. This permits the spray jet to penetrate more deeply into the granulated material while ensuring optimum distribution across the spraying width. The spraying width can additionally be adjusted to meet specific requirements.

Metering Panel For Easy Monitoring Of Binder Metering

The metering panel with screen can be used to adjust and monitor all important parameters related to binder metering. The main functions of the machine can also be selected via the metering panel.



Perfect Injection Pressure
VARIO injection bars

Precise Metering
Separate binding agent metering panel

Low spraying volume

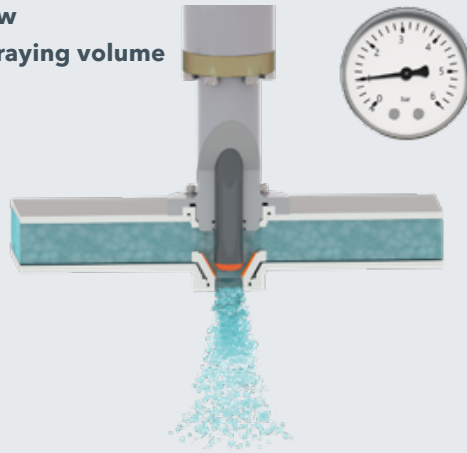

High spraying volume

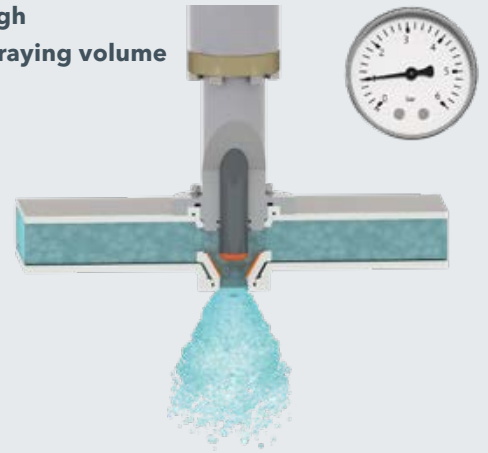

**Cleaning -
e.g. manual
pricking**

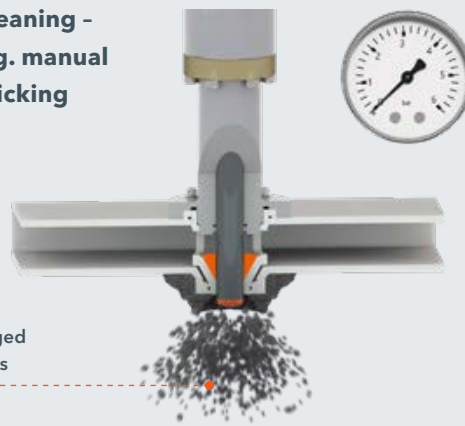

Dislodged
residues

Functional principle: variable nozzle cross-section of the injection bar for water or bitumen emulsion.

01 The injection system feeds water into the mixing chamber in a microcontroller-controlled process and in accordance with the mix formulation to achieve the optimum moisture content.

02 Two injection bars can be operated simultaneously when adding water and bitumen emulsion.

02

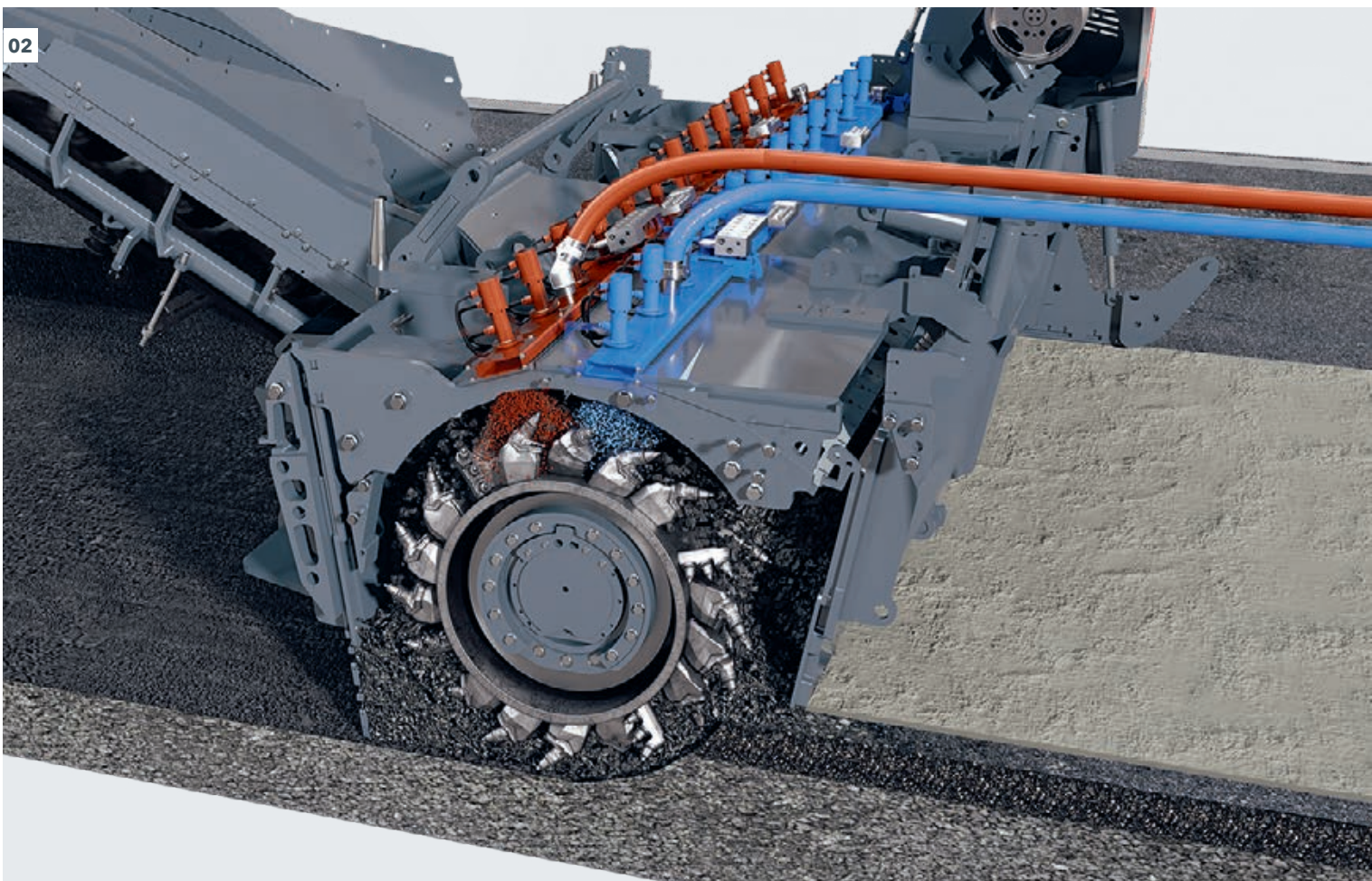

HIGH-PRECISION, RELIABLE INJECTION SYSTEMS

Electrically Heated Bitumen System

The bitumen-carrying components are electrically heated and fitted with short feed hoses to ensure easy, reliable processing of the hot bitumen at temperatures of up to 180°C. The temperature of the bitumen injection system can be adjusted in line with requirements so that it can also be used for processing bitumen emulsion at lower temperatures.

Process Water Monitoring for the Production of Foamed Bitumen

The continuous, unobstructed flow of the amount of process water injected into the expansion chamber during foamed bitumen production is monitored and displayed via the additional process water monitoring feature.

Automatic Self-Cleaning and Flushing Feature

During the recycling operation, any foreign matter is removed from the **VARIO** injection bars by means of time-controlled cleaning (flushing) of the injection nozzles. During breaks or at the end of the recycling operation, the nozzles are additionally cleaned manually or automatically by piercing the closing cylinder at the nozzle outlet.

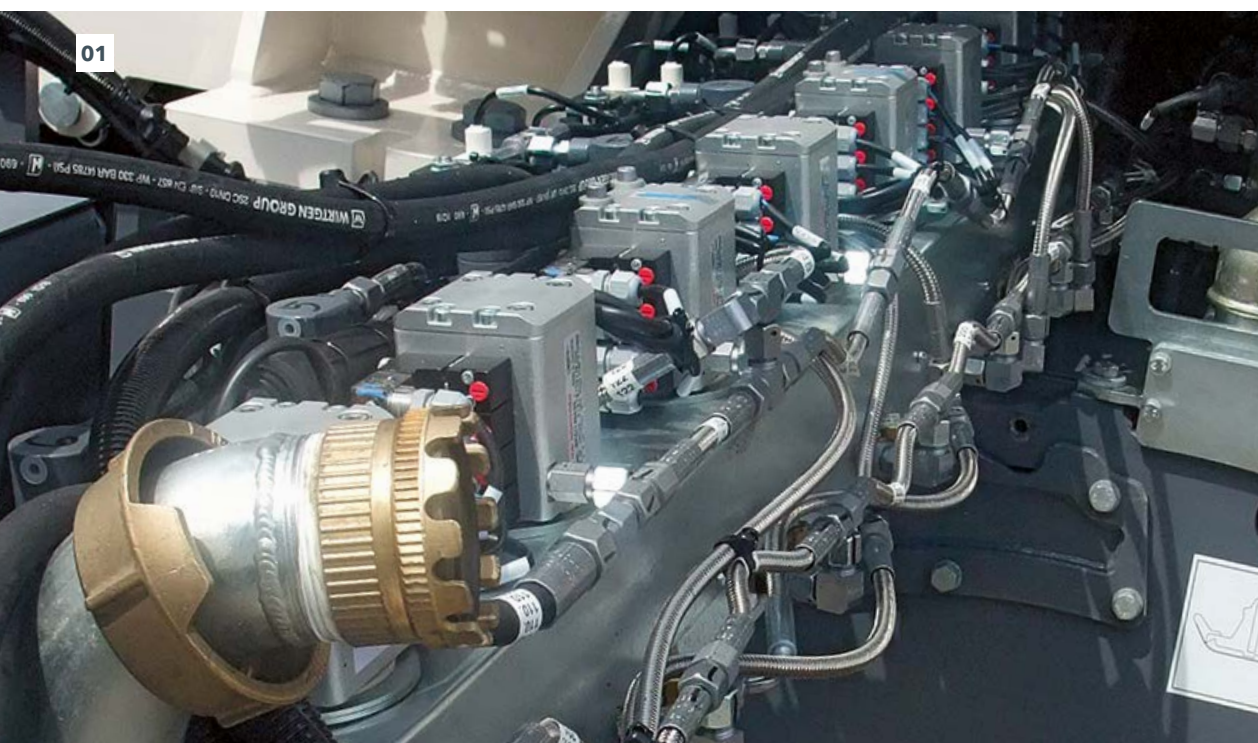

- 01** For base layers of exceptionally high quality, foamed bitumen is produced in separate expansion chambers by injecting water and compressed air into bitumen previously heated to approx. 180°C.
- 02** The microcontroller-controlled injection system injects foamed bitumen and water into the mixing chamber in precisely metered quantities.

Work without Interruptions
Automatic self-cleaning function

Small Injection Quantity

Large Injection Quantity



Foamed bitumen is produced by injecting compressed air and water into hot bitumen in a controlled process.

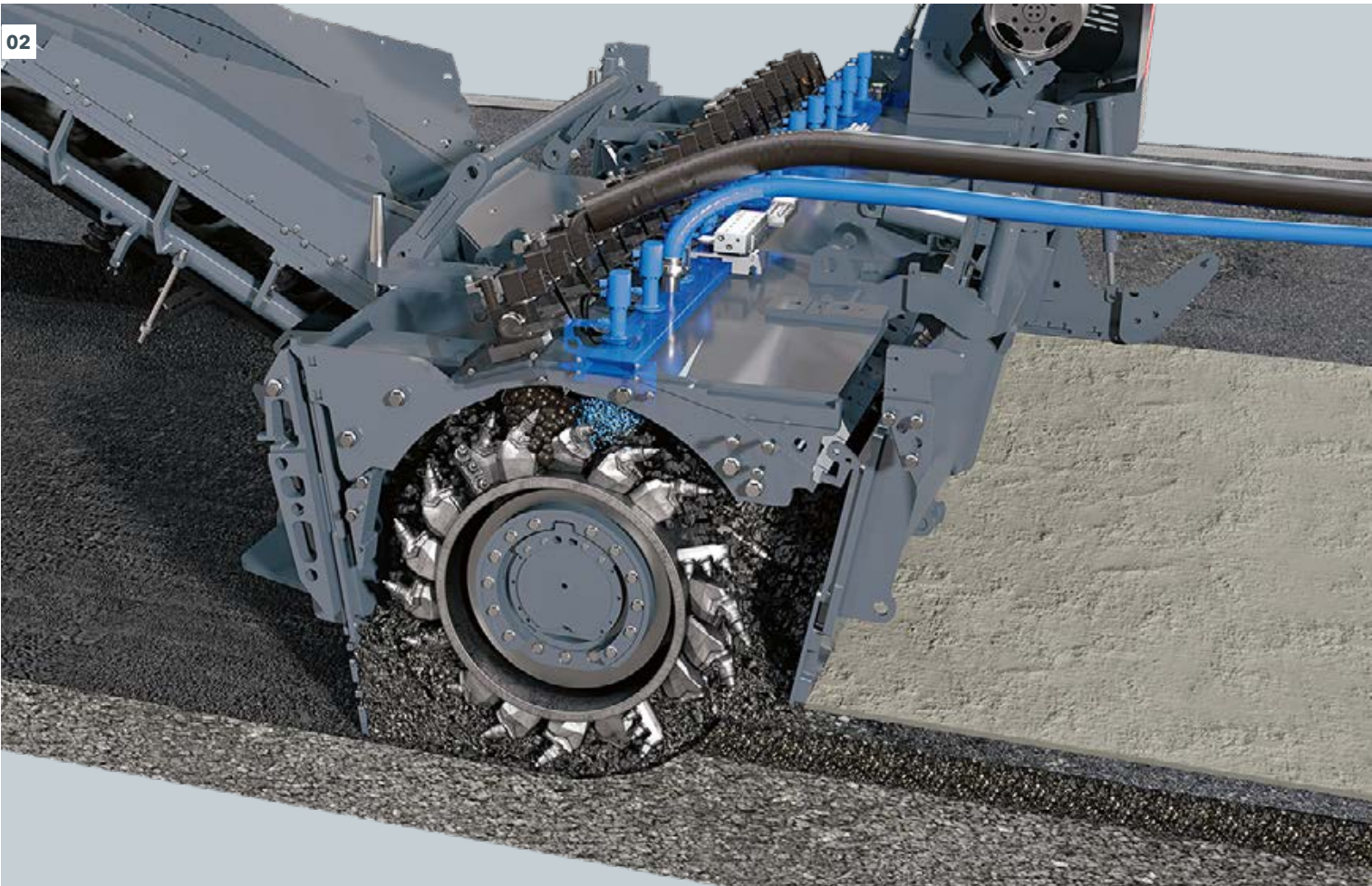

EFFECTIVE CUTTING AND MIXING TECHNOLOGY

Perfectly Designed Milling and Mixing Unit

The milling and mixing unit is designed for heavy-duty milling and mixing applications. It is ideally suited for both the down-cut process, which produces the ideal particle gradation and is the preferred method in cold recycling, and the tried-and-tested up-cut process which is used in front-loading milling operations. The side plates, scraper and rotor plate require only minor modifications to be suitable for use in both directions of operation. The large stroke of the machine's height adjustment feature and wide-opening rotor plate permit additional premilled material to be included in the recycling process.

Extremely Hard-Wearing HT22 Quick-Change Toolholder System

The milling and mixing rotors fitted with the HT22 quick-change toolholder system are ideally suited to perform complex recycling and milling operations. The upper parts of the quick-change toolholders can be replaced quickly and effortlessly right on the construction site.

Easy Pick Replacement

The hydraulically operated rotor rotation device, used in combination with the hydraulic pick ejector drift or pneumatic pick driver and ejector drift, facilitates pick replacement – even with the engine switched off. The large stroke of the machine's height adjustment feature and wide-opening rotor plate additionally optimize accessibility and operator comfort.

MCS for Working Widths of 3.2 m, 3.5 m and 3.8 m

To enhance the flexibility of the W 380 CR(i) the **MCS EXTEND** milling and mixing unit can be converted to working widths of 3.2 m, 3.5 m or 3.8 m within a short period of time. This is realized by mounting additional extension elements for the rotor, rotor housing and injection bars.

Reduced Wear

HT22

Extend Your Capabilities

MCS EXTEND for larger working widths



MCS **EXTEND** Milling and Mixing Unit of the W 380 CR(i) With a Working Width of 3,2 m

02

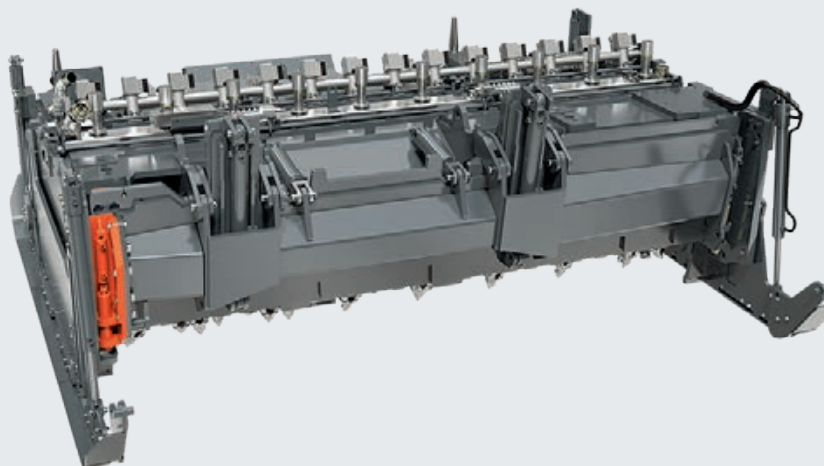

MCS **EXTEND** Milling and Mixing Unit of the W 380 CR(i) With a Working Width of 3,5 m

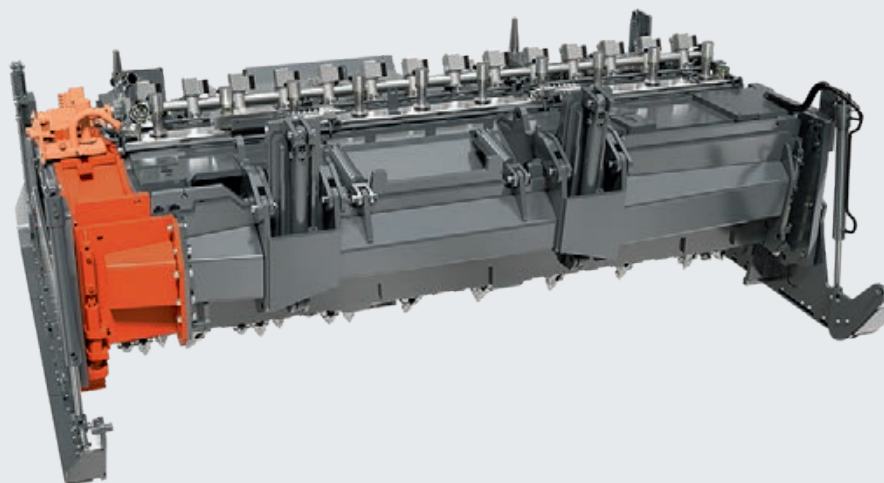

MCS **EXTEND** Milling and Mixing Unit of the W 380 CR(i) With a Working Width of 3,8 m

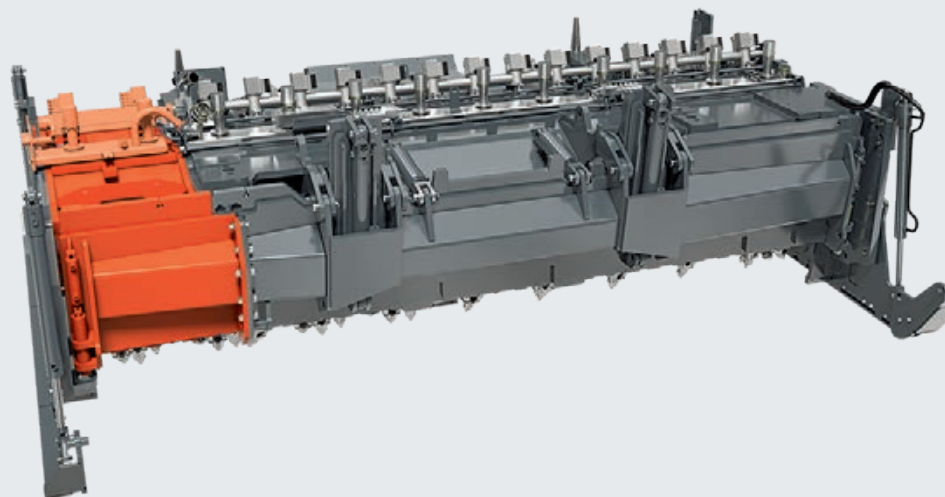

01 The milling and mixing unit is suitable for use in both directions of operation.

02 The MCS **EXTEND** milling and mixing unit of the W 380 CR(i) can be converted to working widths of 3.2 m, 3.5 m or 3.8 m.

W 240 CR(i) WITH INTEGRATED PAVING SCREED

Recycling In a Single Pass Using the W 240 CR(i)

The high mixing capacity of the W 240 CR(i) cold recycler permits the production of larger quantities of recycling mix. The milling and mixing rotor mills and mixes the granulated material with the specified binders prior to transferring the mix to the primary conveyor for transport to the adjustable paving screed. The screed not only offers variable paving widths but is also capable of recycling large lane widths in a single machine pass.

VÖGELE Paving Screed with Automatic Screed Feature

High-quality paving true to grade and slope is ensured by the tried-and-tested, continuously adjustable VÖGELE AB 375 T extending screed. The spreading auger spreads the mix across the full paving width ahead of the screed. The centrally split spreading auger can be operated in clockwise or counter-clockwise rotation. The AB 375 T screed offers numerous ef-

fective automatic features such as the auto-hold feature or automatic start-stop feature. The screed is installed at the rear of the machine and can be mounted or removed quickly and easily as required. In compact design and with integrated paving screed, the W 240 CR(i) is the perfect choice for performing recycling operations even in restricted conditions – for example, on secondary roads.

LEVEL PRO Leveling System

The integrated LEVEL PRO leveling system with clearly structured, fully adjustable control screens is equipped with Sonic Ski and cross slope sensors to ensure precise paving of the recycled mix to the specified level. The leveling system offers the big advantage of being perfectly matched with the machine technology of the cold recycler.



A Example of Application Using the W 240 CR(i)

Recycling with integrated paving screed
(lateral premilling permits variable working widths)



02

01 The integrated paving screed of the W 240 CR(i) paves the recycled mix to perfection.

02 The additional **LEVEL PRO** leveling screen and screed control screen are positioned in line with ergonomic principles.

W 380 CR(i) WITH INTEGRATED REAR LOADING

Recycling in a Single Pass Using the W 380 CR(i)

The W 380 CR(i) cold recycler boasts a mixing capacity of up to 800 t/h, which permits the production of larger quantities of recycling mix. The mix is then transferred to the VÖGELE paver following right behind the recycler via the integrated conveyor system. The powerful paving screed is capable of paving large layer thicknesses and large lane widths in a single machine pass.

High-Capacity Folding and Slewing Discharge Conveyor

The W 380 CR(i) is equipped with a powerful conveyor system with extremely high conveying capacity. The slewing, height-adjustable discharge conveyor with adjustable belt speed enables huge amounts of material to be moved with speed and flexibility. The discharge conveyor can additionally be mounted or removed quickly and easily as required.

Material Hopper with Large Storage Capacity

When cold recycling using the integrated rear-loading feature, the asphalt mix is transported into the paver's material hopper via the discharge conveyor. The hopper acts as an ideal material buffer with ample storage capacity, making it easy to equalize any ground irregularities.

Controlled Transfer of Excess Material

Excess material can be removed from the process and loaded into trucks via the slewable discharge conveyor.



B Example of Application Using the W 380 CR(i)
Recycling with loading conveyor and paver
(lateral premilling permits variable working widths)



01 The W 380 CR(i) recycles road pavements at a mixing capacity of up to 800 t/h.

W 240 CR - W 380 CRi WITH LATERAL PREMILLING



Material Guide Plate System for Variable Paving Widths

Granulated material produced in milling operations previously performed by small or compact milling machines is picked up via the adjustable material guide plate system installed at the front of the machine and added to the mixing process. The recycler's increased mixing capacity teams up with the adjustable paving screed, or the rear-loading process and VÖGELE paver following behind, to rehabilitate even variable pavement widths with flexibility and in a single machine pass.

The two guide plates of the material guide plate system can be independently adjusted mechanically to the width of the previously produced material windrow. Height and contact pressure are adjusted hydraulically.



01 - 02 The recycler picks up the granulated material produced in a previous milling operation via the integrated guide plate system to recycle the road pavement across the full width.

C Example of Application Using the W 240 CR(i) / W 380 CR(i)
Lateral premilling and recycling with loading conveyor and paver



W 240 CR - W 380 CRi: ADDITIONAL APPLICATIONS

In addition to the high-performance recycling of road pavements as the main application, the cold recycler is also capable of milling, homogenizing or granulating asphalt pavements. This maximizes machine utilization.

Milling:

The cold recycler can also be operated as an efficient high-performance large milling machine using the up-cut process. An ultra-strong engine and high conveying capacity make it the ideal candidate for milling jobs requiring extremely high outputs, such as the reclamation of asphalt pavements at full depth. High advance rates and milling depths guarantee the quick completion of large construction projects on motorways or airport runways.

Homogenizing:

The machine is also capable of homogenizing, for example, asphalt layers with an underlying gravel layer. The mixture is deposited and subsequently overlaid with new bound layers.

Granulating:

The powerful cold recycler granulates the damaged asphalt layers to specification without adding any binders to the process. The granulated construction material produced in the process is added to the existing granular layer and subsequently overlaid with a bound pavement layer.

01



- 01 The machine can be operated as an efficient high-performance large milling machine using the up-cut process.
- 02 Homogenizing asphalt base layers is also part of the cold recycler's scope of applications.
- 03 The W 240 CR(i) can be easily transported as a single unit.

02



Ease of Transport

The compact W 240 CR(i) can be easily transported as a single unit on a low-loader truck. This offers the major advantage of allowing the W 240 CR(i) to be transported with both the paving screed and discharge conveyor mounted on the machine.

The large milling and mixing unit of the W 380 CR(i) can be mounted or removed quite easily thanks to a quick-mounting feature and made ready for shipment on a mounting and transport carriage.

03







Cold In-place Recycling (CIR) and Full Depth Reclamation (FDR): the CR series machines are used as part of a paving train for the economical cold in-place recycling of road pavements in a single pass adding cement, emulsion or foamed bitumen, featuring a mixing capacity of up to 800 t/h. Traffic lanes are rehabilitated quickly and easily using the compact W 240 CR(i) cold recycler with integrated paving screed. The powerful W 380 CR(i) rear loader recycles extra wide road pavements across the full width, offering exceptionally high daily performance rates.



| TECHNICAL SPECIFICATIONS | W 240 CR | W 240 CR i |
|--|---|---|
| Milling and Mixing Rotor | | |
| Working width | 2,350 mm | |
| Working depth ¹⁾ | 0 to 350 mm | |
| Drum diameter with tools | 1,140 mm | |
| Rotor speed at maximum operating speed | 108 rpm | 100 rpm |
| Engine | | |
| Manufacturer | Caterpillar | |
| Type | C27 ATAAC | |
| Cooling | Water | |
| Number of cylinders | 12 | |
| Power | at 2,100 rpm: 708 kW / 950 HP / 963 PS | at 2,000 rpm: 653 kW / 875 HP / 888 PS |
| Maximum power | at 1,800 rpm: 708 kW / 950 HP / 963 PS | at 1,800 rpm: 775 kW / 1.038 HP / 1.054 PS |
| Displacement | 27.2 l | |
| Fuel consumption, full load | 187 l/h | 195 l/h |
| Fuel consumption, field mix | 75 l/h | 80 l/h |
| Exhaust emission standard | no EU regulation / US Tier 2 | EU Stage 5 / US Tier 4f |
| Electrical System | | |
| Voltage supply | 24 V | |
| Filling Capacities | | |
| Fuel | 1,400 l | |
| Hydraulic fluid | 350 l | |
| Water | 4,000 l | |
| Driving Performance | | |
| Operating and travel speed | 0 to 88 m/min (0 to 5.3 km/h) | |
| Track Units | | |
| Track units, front and rear (L x W x H) | 2,250 x 370 x 790 mm | |
| Conveyor System | | |
| Belt width of primary conveyor | 1,100 mm | |
| Belt width of discharge conveyor | 1,100 mm | |
| Theoretical capacity of discharge conveyor | 668 m ³ /h | |

¹⁾ The maximum working depth may deviate from the value indicated due to tolerances and wear.

| W 380 CR | W 380 CRi |
|---|---|
| 3,800 mm | |
| 0 to 350 mm | |
| 1,140 mm | |
| 108 rpm | 100 rpm |
| Caterpillar | |
| C27 ATAAC | |
| Water | |
| 12 | |
| at 2,100 rpm: 708 kW / 950 HP / 963 PS | at 2,000 rpm: 653 kW / 875 HP / 888 PS |
| at 1,800 rpm: 708 kW / 950 HP / 963 PS | at 1,800 rpm: 775 kW / 1,038 HP / 1,054 PS |
| 27.2 l | 27.2 l |
| 187 l/h | 195 l/h |
| 75 l/h | 80 l/h |
| no EU regulation / US Tier 2 | EU Stage 5 / US Tier 4f |
| 24 V | |
| 1,400 l | |
| 350 l | |
| 4,000 l | |
| 0 to 88 m/min (0 to 5.3 km/h) | |
| 2,250 x 370 x 790 mm | |
| 1,100 mm | |
| 1,100 mm | |
| 668 m ³ /h | |

| TECHNICAL SPECIFICATIONS | W 240 CR | W 240 CR i |
|--|-----------|------------|
| Weight of Basic Machine | | |
| Empty weight of machine in standard design excluding operating fluids | 45,800 kg | |
| Operating weight, CE ²⁾ | 48,500 kg | |
| Maximum operating weight (full tanks, full range of equipment) | 59,400 kg | |
| Weights of Operating Fluids | | |
| Filling of water tank | 4,000 kg | |
| Filling of fuel tank (0.83 kg/l) | 1,150 kg | |
| Additional Add-On Weights | | |
| Operator and tools | | |
| > Operator | 75 kg | |
| > 5 pick containers | 125 kg | |
| Injection systems in lieu of standard | | |
| > Minus ESL: Injection openings in rotor housing closed | -400 kg | |
| > Dual ESL: Injection system with VARIO injection bars for water and bitumen emulsion | 310 kg | |
| > ESL foamed bitumen: Injection system with VARIO injection bars for water and foamed bitumen | 840 kg | |
| Optional additional equipment | | |
| > Paving screed and spreading auger | 4,900 kg | |
| > Material guide plates on the front track units | 900 kg | |
| > Canopy | 500 kg | |
| > Minus discharge conveyor | -2,850 kg | |
| > VCS extraction system | 250 kg | |
| Transport Weights of Single Components | | |
| Empty weight of machine in standard design excluding milling and mixing unit | - | |
| Milling and mixing unit on transport carriage (L x W x H : 4,750 x 2,900 x 2,400 mm) | - | |
| Transport carriage for milling and mixing unit | - | |

²⁾ Machine in standard design, half-full water tank, half-full fuel tank, operator, on-board tools, excluding optional equipment features

| | W 380 CR | W 380 CR i |
|--|----------|------------|
| | | 50,300 kg |
| | | 53,000 kg |
| | | 58,900 kg |
| | | 4,000 kg |
| | | 1,150 kg |
| | | 75 kg |
| | | 125 kg |
| | | -400 kg |
| | | 350 kg |
| | | 900 kg |
| | | - |
| | | 900 kg |
| | | 500 kg |
| | | -2,850 kg |
| | | 250 kg |
| | | 35,100 kg |
| | | 16,500 kg |
| | | 1,300 kg |

SIDE VIEW / TOP VIEW W 240 CR(i) INCLUDING DISCHARGE CONVEYOR

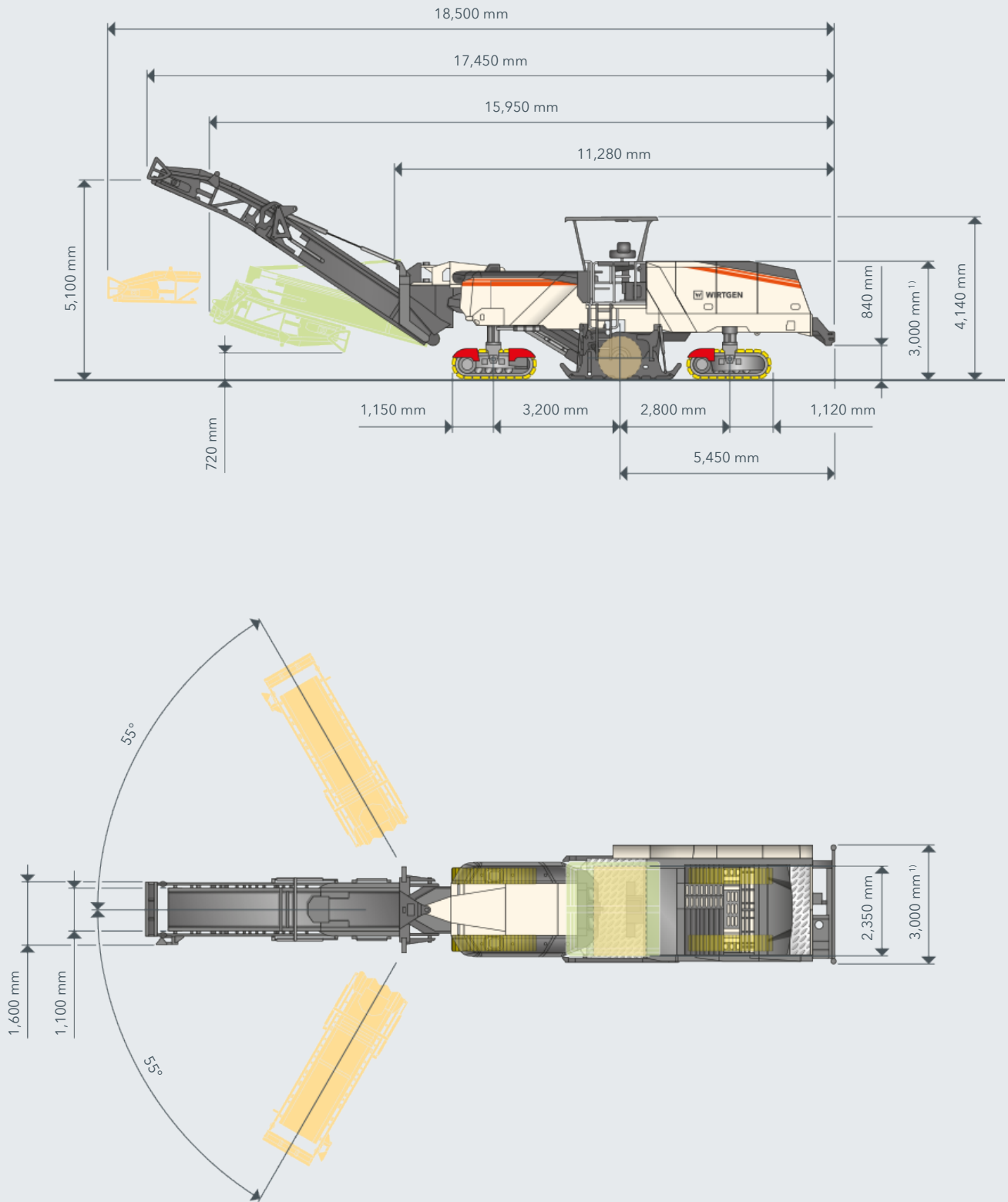

¹⁾ Dimensions for low-loader transport

SIDE VIEW / TOP VIEW W 240 CR(i) INCLUDING PAVING SCREED AND SPREADING AUGER

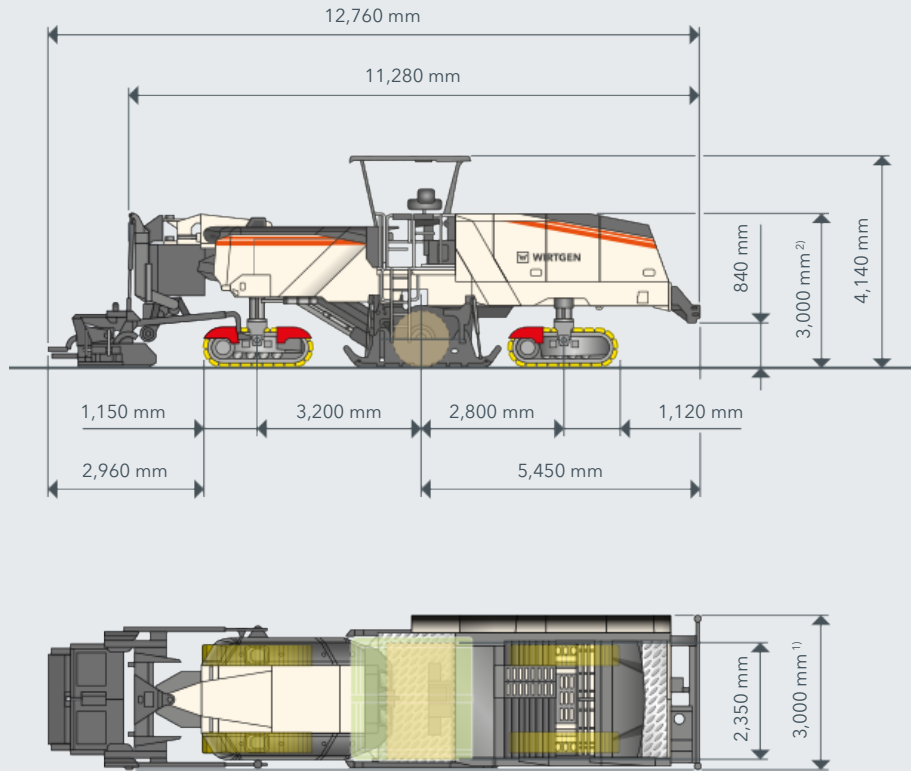

¹⁾ Dimensions for low-loader transport

REAR VIEW W 240 CR(i)

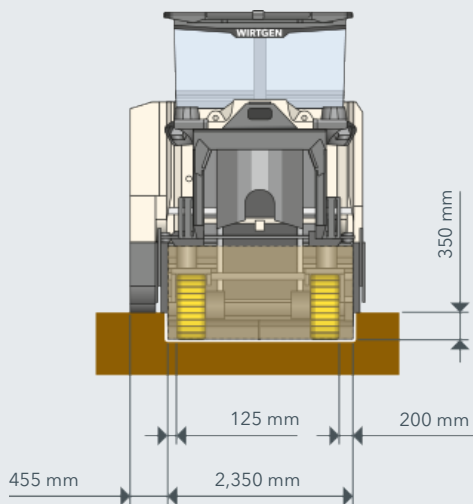

GROUND CLEARANCE W 240 CR(i)

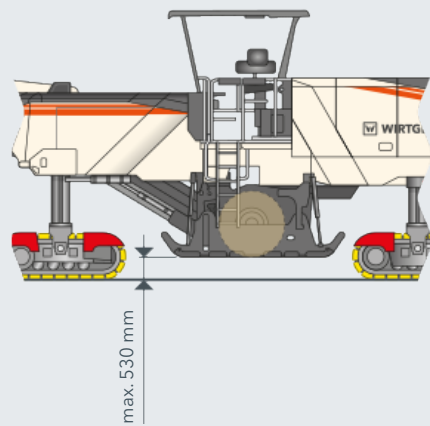

OPERATING RADIUS W 240 CR(i) INCLUDING DISCHARGE CONVEYOR

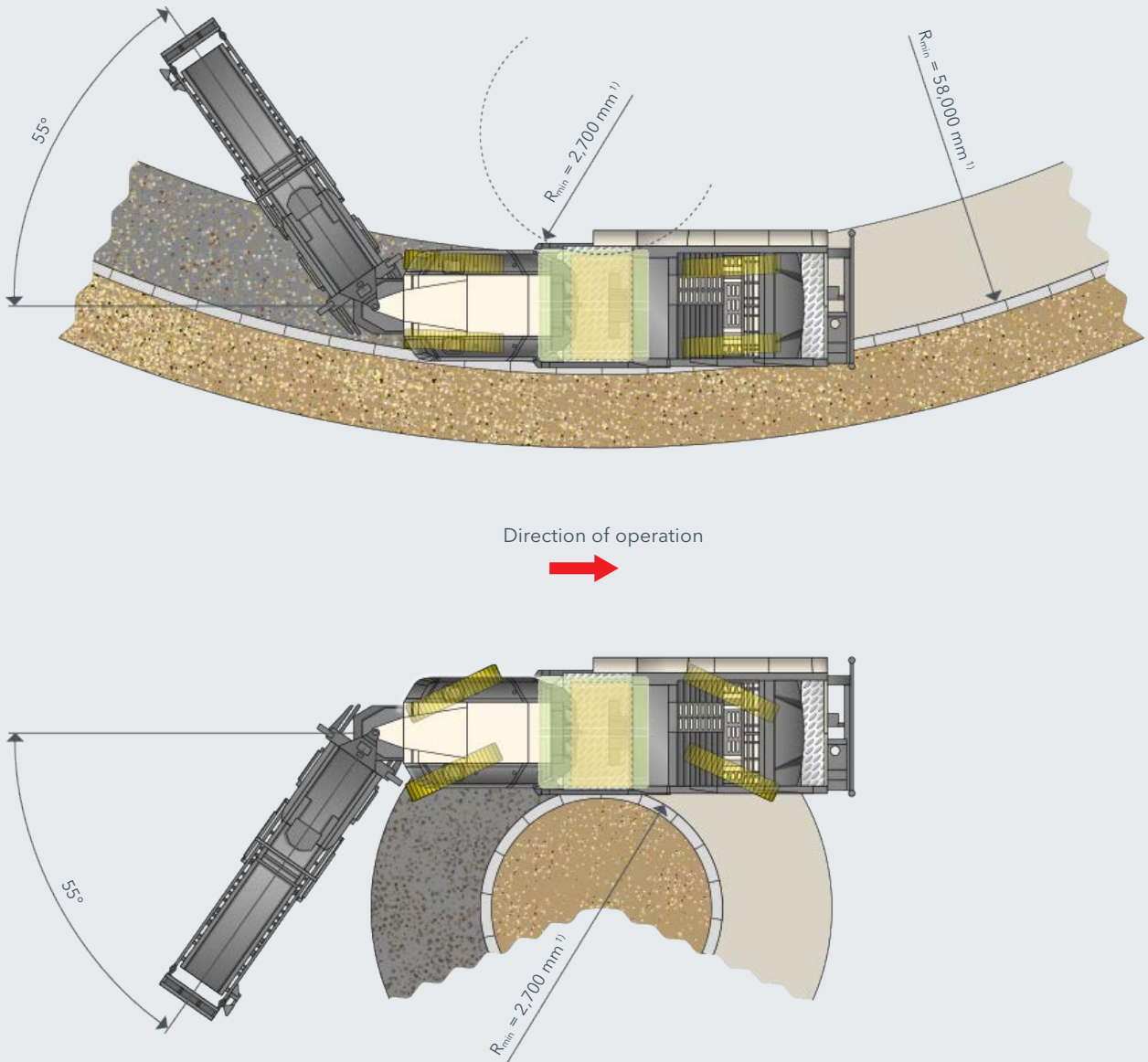

¹⁾ Small operating radii may lead to increased wear of the milling and mixing rotor.

OPERATING RADIUS W 240 CR(i) INCLUDING PAVING SCREED

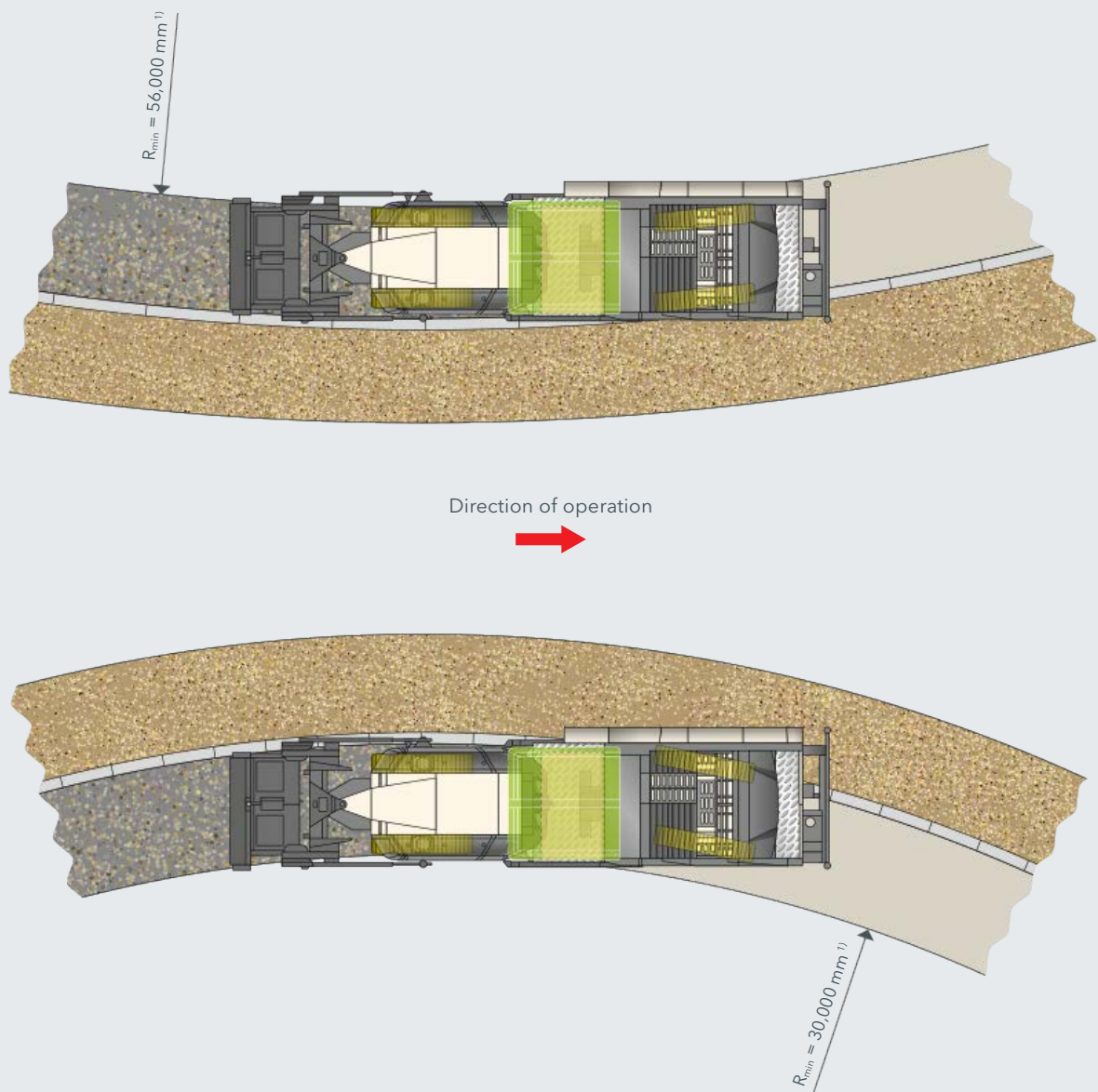

¹⁾ Small operating radii may lead to increased wear of the milling and mixing rotor.

SIDE VIEW / TOP VIEW W 380 CR(i)

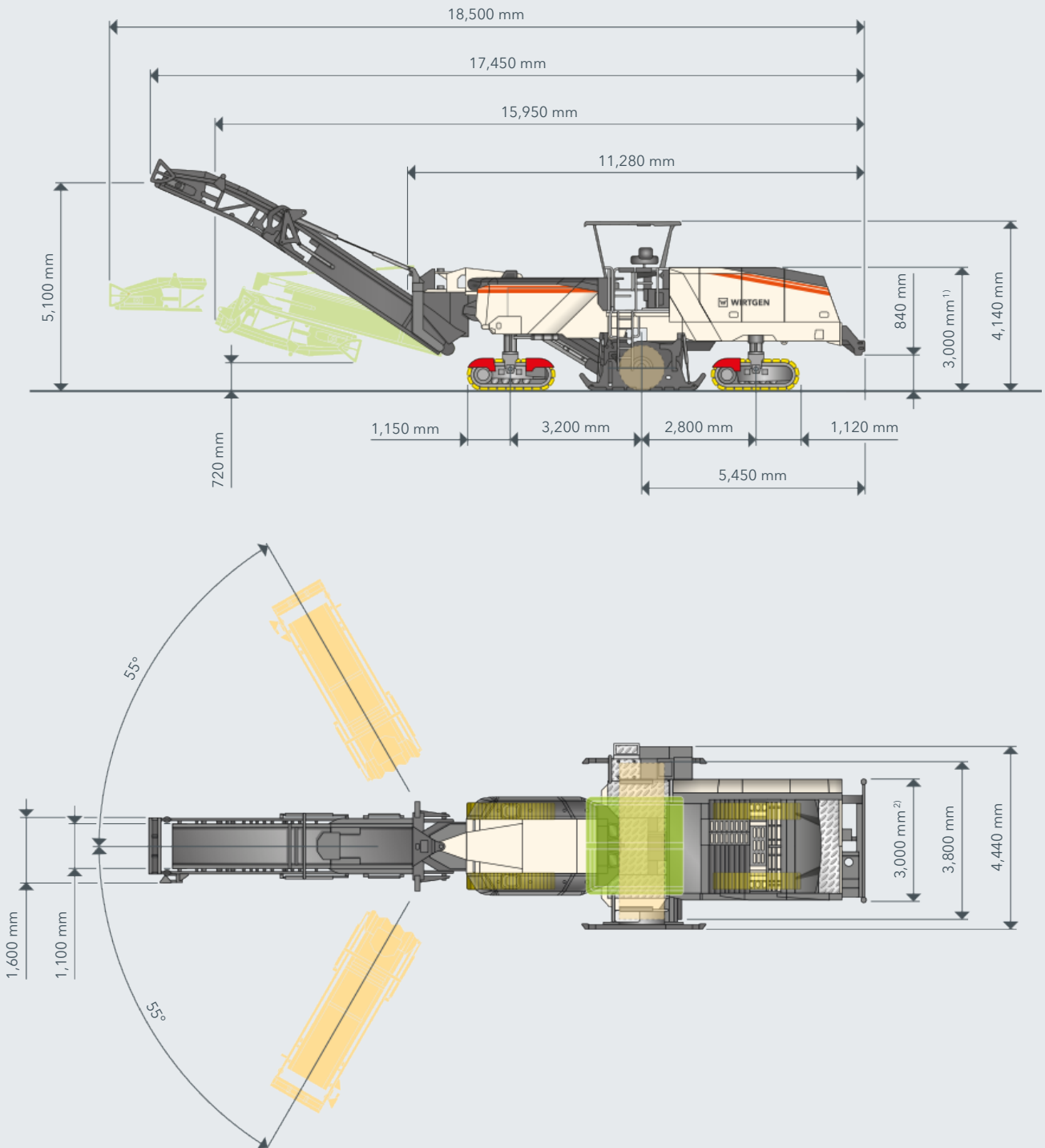

¹⁾ Dimensions for low-loader transport

²⁾ Transport width excluding milling and mixing unit

REAR VIEW W 380 CR(i)

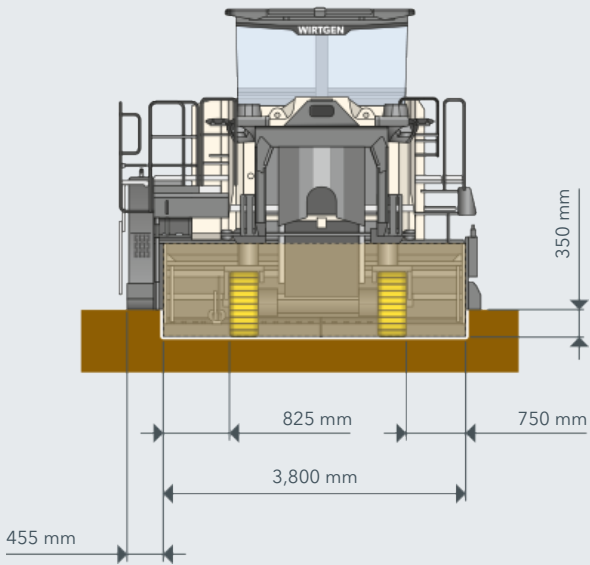

GROUND CLEARANCE W 380 CR(i)

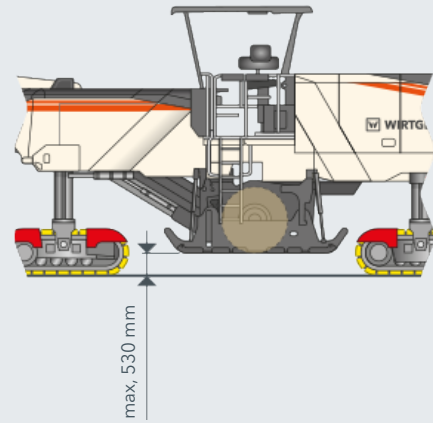

OPERATING RADIUS W 380 CR(i)

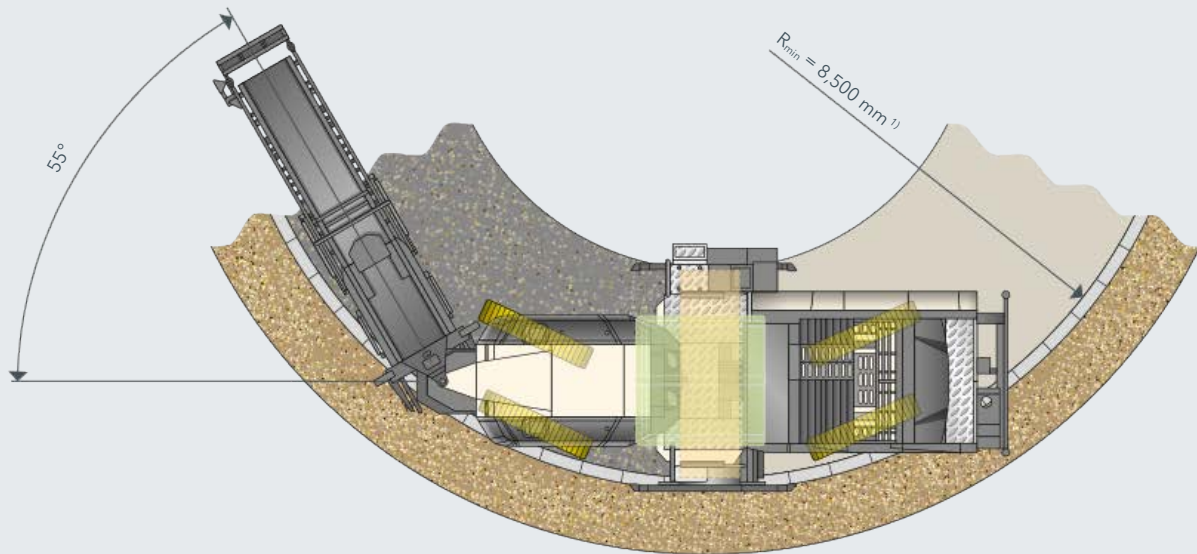

Direction of operation

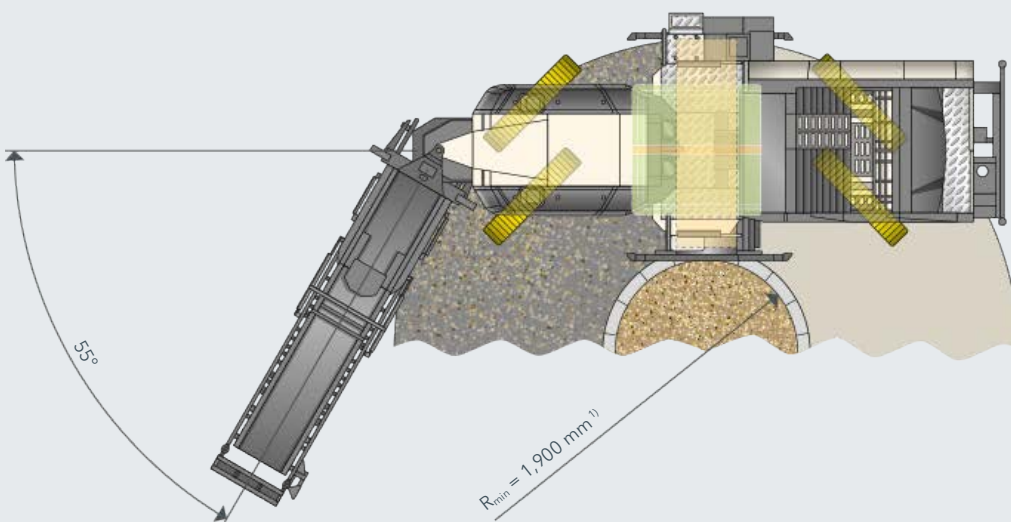

¹⁾ Small operating radii may lead to increased wear of the milling and mixing rotor.

TRANSPORT DIMENSIONS

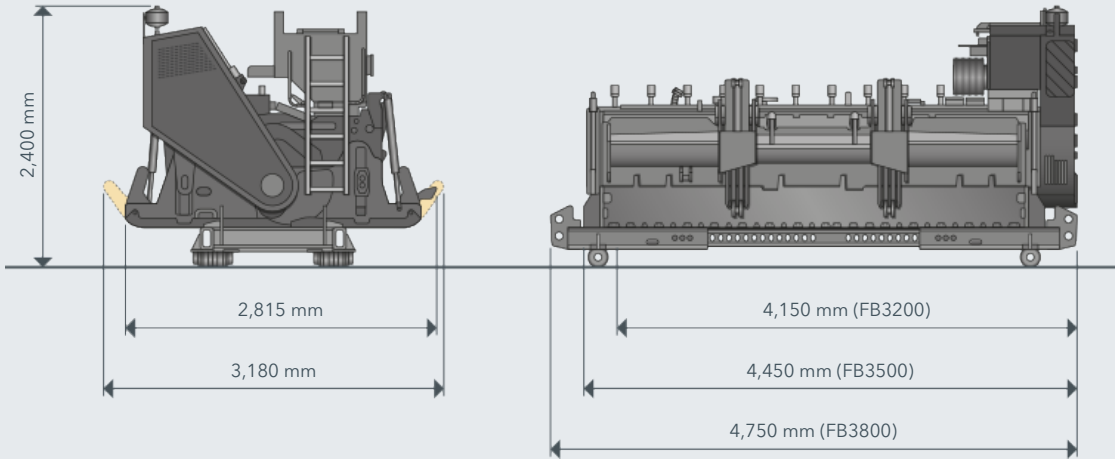

Milling and mixing unit FB3800 including transport carriage

| STANDARD EQUIPMENT | W 240 CR(i) | W 380 CR(i) |
|--|-------------|-------------|
| Basic machine | | |
| > Base machine with engine | ■ | ■ |
| > The machine can be used as a cold recycler in rear-loading mode or as a cold milling machine in front-loading mode | ■ | ■ |
| > Soundproof lining of engine compartment | ■ | ■ |
| > Diesel engine power controller for optimum milling and mixing results | ■ | ■ |
| > Load limit controller for optimum operation in down-cut mode | ■ | ■ |
| > Engine cooling system with temperature-controlled fan speed | ■ | ■ |
| > Machine frame providing optimum visibility for rear- and front-loading operations | ■ | ■ |
| > Air compressor system, max. 8 bar | ■ | ■ |
| > Battery-operated hydraulic unit | ■ | ■ |
| > Mechanical drum drive via high-performance V-belts with automatic belt tensioner | ■ | ■ |
| > Milling drum gearbox for down-cut operation in rear-loading mode | □ | □ |
| Milling and Mixing Unit | | |
| > Three electrically selectable milling drum speeds | ■ | ■ |
| > Quick and easy conversion from rear-loading to front-loading operation | ■ | ■ |
| > Water spray system with automatic on / off function including two spray bars in the milling and mixing unit | ■ | ■ |
| > Hydraulically movable and adjustable front drum plate with exchangeable carbide elements | ■ | ■ |
| > Rear drum sealing plate with hydraulic conveyor lifting feature and exchangeable carbide elements | ■ | ■ |
| > Hydraulically lifting side plates, optimized for both directions of operation | ■ | ■ |
| > Milling drum housing FB2350 | ■ | — |
| > Milling drum housing FB3800 | — | □ |
| Milling and Mixing Rotor | | |
| > Milling and mixing rotor FB2350 HT22 LA15 D20 with 198 picks | ■ | — |
| > Milling and mixing rotor FB3800 HT22 LA15 D20 with 294 picks | — | □ |
| > Power multiplier for defined bolt tightening when changing the milling drum unit | — | ■ |
| Loading of the Milled and Mixed Material | | |
| > Conveyor system with manually or automatically adjustable conveying speed | ■ | ■ |
| > Two slewing speeds on the hydraulically foldable discharge conveyor | ■ | ■ |
| > Water sprinkling system in the primary conveyor | ■ | ■ |
| > Primary conveyor: 1,100 mm discharge conveyor belt width, material depressor with scraper function | ■ | ■ |
| > Discharge conveyor, 1,100 mm wide, with hydraulic folding device | □ | ■ |
| Injection System / Addition of Binders | | |
| > Single ESL (FB2350): spraying system with VARIO spray bar for water or bitumen emulsion (800 l/min) | □ | — |
| > Single ESL (FB3800): spraying system with VARIO spray bar for water or bitumen emulsion (800 l/min) | — | □ |
| > Model without extension elements for spraying system | — | □ |
| Paving Unit | | |
| > Model without spreading auger and without paving screed | □ | — |

| STANDARD EQUIPMENT | W 240 CR (i) | W 380 CR (i) |
|---|--------------|--------------|
| Machine Control and Leveling System | | |
| > Multifunctional color control screen displaying important machine operating conditions | ■ | ■ |
| > Extensive machine diagnostics in the machine display | ■ | ■ |
| > Automated features to reduce the machine operator's workload | ■ | ■ |
| > Four exterior control panels for operating functions performed by the ground crew | ■ | ■ |
| > LEVEL PRO leveling system for milling depth control, including one control screen and one each electrical height sensor in the hydraulic cylinders on the side plates, right and left | ■ | ■ |
| Operator's Platform | | |
| > Fully anti-vibration mounted operator's platform | ■ | ■ |
| > Convenient access to the operator's platform, left and right | ■ | ■ |
| > Fold-out extension of operator's platform, right | ■ | ■ |
| > Large storage compartment and stand-up seats, left and right | ■ | ■ |
| > Two mirrors at the front, two mirrors at the rear of the machine | ■ | ■ |
| > Walk-through operator's platform with one each control panel, right and left | ■ | ■ |
| > The control panels can be adjusted in height, rotated and positioned in line with ergonomic principles and the machine's direction of operation | ■ | ■ |
| > Lockable control panel covers | ■ | ■ |
| > Camera at the front with two screens, right and left | ■ | ■ |
| Track Unit and Height Adjustment | | |
| > PTS - automatic alignment of the machine parallel to the pavement surface | ■ | ■ |
| > ISC - intelligent track speed control including hydraulic four-track drive | ■ | ■ |
| > Fourfold full-floating axle for high machine stability | ■ | ■ |
| > High ground clearance for improved access when replacing picks or removing the milling and mixing unit | ■ | ■ |
| > Four-track steering system offering the following steering modes in both directions of operation: crab, cornering or straight-ahead mode | ■ | ■ |
| > Extremely wear-resistant, two-part EPS Plus polyurethane track pads | ■ | ■ |
| Miscellaneous | | |
| > Air compressor system, max. 8 bar | ■ | ■ |
| > Washdown system with hose reel and cleaning gun | ■ | ■ |
| > Comprehensive LED lighting system, 24 V | ■ | ■ |
| > "Welcome-and-Go-Home-Light" feature including LED lighting in the area of the operator's platform and access | ■ | ■ |
| > Large tool kit in lockable tool box | ■ | ■ |
| > EMERGENCY STOP switches in appropriate positions on the machine | ■ | ■ |
| > Pre-fitting for installing the WITOS FleetView control unit "WIRTGEN Road Technologies Telematics and on-site Solutions" (WITOS) is the intelligent telematics system of the WIRTGEN Road Technologies for efficient fleet and service management worldwide | ■ | ■ |
| > Water tank filling from rear of machine | □ | □ |
| > Standard painting in RAL 9001 (cream) | □ | □ |
| > WITOS - professional telematics solution for machine operation and service optimisation | □ | □ |

■ = Standard equipment

□ = Standard equipment, can be replaced with optional equipment if desired

□ = Optional equipment

| OPTIONAL EQUIPMENT | W 240 CR(i) | W 380 CR(i) |
|--|--------------------------|--------------------------|
| Basic Machine | | |
| > Milling drum gearbox for up-cut operation in rear-loading mode | <input type="checkbox"/> | <input type="checkbox"/> |
| Milling and Mixing Unit | | |
| > Milling drum housing FB3200 MCS EXTEND | — | <input type="checkbox"/> |
| > Milling drum housing FB3500 MCS EXTEND | — | <input type="checkbox"/> |
| > Milling drum housing FB3800 MCS EXTEND | — | <input type="checkbox"/> |
| > Ancillary parts for milling drum housing with extension to FB3200 MCS EXTEND | — | <input type="checkbox"/> |
| > Ancillary parts for milling drum housing with extension to FB3500 MCS EXTEND | — | <input type="checkbox"/> |
| > Ancillary parts for milling drum housing with extension to FB3800 MCS EXTEND | — | <input type="checkbox"/> |
| Milling and Mixing Rotor | | |
| > MCS EXTEND milling and mixing rotor, FB3200 HT22 LA15 D20, multi-part, with 239 picks | — | <input type="checkbox"/> |
| > MCS EXTEND milling and mixing rotor, FB3500 HT22 LA15 D20, multi-part, with 258 picks | — | <input type="checkbox"/> |
| > MCS EXTEND milling and mixing rotor, FB3800 HT22 LA15 D20, multi-part, with 277 picks | — | <input type="checkbox"/> |
| > Transport frame for additional MCS milling units MCS EXTEND | — | <input type="checkbox"/> |
| > Assembly aid for additional MCS milling units MCS EXTEND | — | <input type="checkbox"/> |
| Loading of the Milled and Mixed Material | | |
| > Model without discharge conveyor | <input type="checkbox"/> | — |
| > VCS extraction system | <input type="checkbox"/> | <input type="checkbox"/> |
| > Hydraulically adjustable deflector plate on the discharge conveyor | <input type="checkbox"/> | <input type="checkbox"/> |
| > Supports for discharge conveyor | <input type="checkbox"/> | <input type="checkbox"/> |
| Injection System / Addition of Binders | | |
| > Dual ESL (FB2350): spraying system with VARIO spray bars for water and bitumen emulsion (800 l/min + 800 l/min) | <input type="checkbox"/> | — |
| > Dual ESL (FB3800): spraying system with VARIO spray bars for water and bitumen emulsion (800 l/min + 800 l/min) | — | <input type="checkbox"/> |
| > Dual ESL foamed bitumen (FB2350): spraying system with VARIO spray bars for water and foamed bitumen (800 l/min + 500 kg/min) | <input type="checkbox"/> | — |
| > Dual ESL foamed bitumen (FB3800): spraying system with VARIO spray bars for water and foamed bitumen (800 l/min + 500 kg/min) | — | <input type="checkbox"/> |
| > Model without spraying system | <input type="checkbox"/> | <input type="checkbox"/> |
| Injection System / Addition of Binders (MCS EXTEND only) | | |
| > Single ESL (MCS EXTEND): VARIO spraying system for water or bitumen emulsion (800 l/min) | — | <input type="checkbox"/> |
| > Dual ESL (MCS EXTEND): VARIO spraying system for water and bitumen emulsion (800 l/min + 800 l/min) | — | <input type="checkbox"/> |
| > Dual ESL foam bitumen (MCS EXTEND): VARIO spraying system for water and foamed emulsion (800 l/min, 500 kg/min) | — | <input type="checkbox"/> |
| > Model without spraying system MCS EXTEND | — | <input type="checkbox"/> |
| > Extension of single ESL to FB3500 MCS EXTEND or FB3800 MCS EXTEND | — | <input type="checkbox"/> |
| > Extension of dual ESL to FB3500 MCS EXTEND or FB3800 MCS EXTEND | — | <input type="checkbox"/> |
| > Extension of the spraying system for foamed bitumen to FB3500 MCS EXTEND or FB3800 MCS EXTEND | — | <input type="checkbox"/> |
| > Extension without spraying system FB3500 MCS EXTEND or FB3800 MCS EXTEND | — | <input type="checkbox"/> |

| OPTIONAL EQUIPMENT | W 240 CR (i) | W 380 CR (i) |
|---|--------------------------|--------------------------|
| Paving Unit | | |
| > Paving screed type AB 375 T and spreading auger | <input type="checkbox"/> | — |
| > Automatic extending screed control, right and left, using Sonic Ski sensors | <input type="checkbox"/> | — |
| > Cross-slope sensor for extending screed | <input type="checkbox"/> | — |
| Machine Control and Leveling System | | |
| > Ultrasonic sensor for wire or ground scanning | <input type="checkbox"/> | <input type="checkbox"/> |
| > Additional LEVEL PRO control screen | <input type="checkbox"/> | <input type="checkbox"/> |
| > Pre-fitting for multiplex system comprising 4 sensors sockets | <input type="checkbox"/> | <input type="checkbox"/> |
| > 3-way multiplex system, right, including 2 ultrasonic sensors | <input type="checkbox"/> | <input type="checkbox"/> |
| > 3-way multiplex system, right and left, including 4 ultrasonic sensors | <input type="checkbox"/> | <input type="checkbox"/> |
| > Level control 3D leveling pre-equipment | <input type="checkbox"/> | <input type="checkbox"/> |
| > Cross-slope sensor for machine | <input type="checkbox"/> | <input type="checkbox"/> |
| Operator's Platform | | |
| > Weather canopy with electro-hydraulic fold-down feature | <input type="checkbox"/> | <input type="checkbox"/> |
| Miscellaneous | | |
| > Hydraulically operated filling pump for water refilling | <input type="checkbox"/> | <input type="checkbox"/> |
| > Painting in one special color (RAL) | <input type="checkbox"/> | <input type="checkbox"/> |
| > Painting in two special colors (RAL) | <input type="checkbox"/> | <input type="checkbox"/> |
| > Model without WITOS | <input type="checkbox"/> | <input type="checkbox"/> |
| > USB interface for retrieving the job data | <input type="checkbox"/> | <input type="checkbox"/> |
| > Transport carriage for milling drum units from FB2200 to FB4400 | — | <input type="checkbox"/> |
| > High-pressure water cleaner, 190 bar, 15 l/min | <input type="checkbox"/> | <input type="checkbox"/> |
| > Guide plates on the front track units to guide previously deposited material | <input type="checkbox"/> | <input type="checkbox"/> |
| > Milling drum rotation device for milling and mixing unit FB2350 | <input type="checkbox"/> | — |
| > Milling drum rotation device for the milling and mixing units FB3200 - FB3800 | — | <input type="checkbox"/> |
| > Pneumatic hammer with pick extractor / inserter | <input type="checkbox"/> | <input type="checkbox"/> |
| > Hydraulic pick ejector | <input type="checkbox"/> | <input type="checkbox"/> |
| > Diesel tank filling pump with 5.00 m suction hose | <input type="checkbox"/> | <input type="checkbox"/> |
| > Wiggins fast-fill system for diesel refuelling | <input type="checkbox"/> | <input type="checkbox"/> |
| > Additional camera on the discharge conveyor | <input type="checkbox"/> | <input type="checkbox"/> |
| > Additional monitor system including 5 cameras and monitor | <input type="checkbox"/> | <input type="checkbox"/> |
| > Pre-fitting for two LED lighting balloons | <input type="checkbox"/> | <input type="checkbox"/> |
| > LED lighting balloon, 24 volt | <input type="checkbox"/> | <input type="checkbox"/> |
| > Suction hose for hot bitumen 3", 4000 LG | <input type="checkbox"/> | <input type="checkbox"/> |
| > Suction hose for water or emulsion 3", 5000 LG | <input type="checkbox"/> | <input type="checkbox"/> |
| > Support arm for holding the push bar and feed lines whilst changing tankers | <input type="checkbox"/> | <input type="checkbox"/> |

- = Standard equipment
 = Standard equipment, can be replaced with optional equipment if desired
 = Optional equipment

**WIRTGEN GmbH**

Reinhard-Wirtgen-Str. 2
53578 Windhagen
Germany

T: +49 2645 131-0
F: +49 2645 131-392
M: info@wirtgen.com

 www.wirtgen.de



For further information, please scan the code.