

High-performance front loader for narrow major job sites

COLD MILLING MACHINE W 150 CF (i)



HIGH-PERFORMANCE FRONT LOADER FOR NARROW MAJOR JOB SITES

The most powerful cold milling machine in the compact class is particularly suitable for large-scale job sites where space is limited, such as in urban areas.

FCS enables the use of different milling drums up to a maximum working width of 1.8 m for greater flexibility and machine utilization.

The machine's low weight and centrally positioned milling drum unit ensure that its weight is ideally distributed.

The particularly wide swing angle and the speed of the front-loading conveyor can be flexibly adjusted for optimum loading of the milled material.

The state-of-the-art machine control system with the **LEVEL PRO PLUS** leveling system and the intuitive user interface make efficient one-person operation possible.



WIRTGEN COLD MILLING MACHINES



SMALL MILLING MACHINES
> Milling width to 1,300 mm
> Milling depth to 300 mm

COMPACT MILLING MACHINES
> Milling width to 1,900 mm
> Milling depth to 330 mm

LARGE MILLING MACHINES
> Milling width to 4,400 mm
> Milling depth to 350 mm

OVERVIEW OF HIGHLIGHTS

Perfectly Equipped

01 High-Precision, Intuitive Leveling with LEVEL PRO PLUS

- > Simple, intuitive operation
- > Fully integrated into the machine control system
- > Milling depth measurement via displacement sensors installed in the hydraulic side plate cylinders
- > Hydraulic scanning sensor in front of the milling drum

02 Efficient Multifunctional Armrest

- > Ergonomically designed multifunctional armrest with color control screen
- > Scraper position displayed on the control screen
- > Job data displayed on the control panel
- > User-programmable favorites buttons

03 Perfect Visibility for High-Precision Work

- > Variably adjustable weather canopy
- > High-quality camera / monitor system with up to five cameras for viewing important working areas
- > Optimized headlight arrangement and optional LED headlights for maximum visibility at night

04 Comfortable Operator's Cabin

- > Ergonomically designed comfort operator's seat including seat heater
- > Easy access with "welcome and go home" lighting
- > Operator's cabin features wind and weather protection elements
- > Additional controls for the ground crew



05 Fast Maneuvering with High Traction

- > ISC electronic track chain control for low track pad wear and optimum traction
- > Up to 7.5 km/h travel speed
- > Automatic parallel machine alignment through optimized PTS
- > "Stop-and-go" display for the truck driver

06 Light and Maneuverable Machine

- > Large steering angles for tight turning radii
- > High-precision steering via joystick in multifunctional armrest
- > Extremely light for this weight class with variable ballasting weight of up to 900 kg
- > Additional height adjustment in increments of 1 mm or 5 mm

**07 Impressive Milling Performance in a Variety of Applications**

- > Milling drum rotation device and hydraulic pick ejector for fast pick changes
- > Hydraulically lifting side plates with proactive floating position to automatically lift on loose ground
- > Scraper raises automatically via overload sensor
- > Comes standard with extremely wear-resistant HT22 quick-change toolholder system
- > FCS complete unit FB1500 with easily exchangeable milling drums FB600, FB900, FB1200, and FB1500
- > Alternative milling width of 1.8 m

08 High Loading Volume with Maximum Flexibility

- > Wide conveyor swing angles of 60° to the right and left
- > Two conveyor swing speeds for high-precision loading of the milled material
- > VCS extraction system with optimized suction channel for minimum cleaning effort
- > Hydraulic folding conveyor for quick folding during operation on site
- > Quick-change coupling for easy mounting and removal of the discharge conveyor

09 Maximum Efficiency for Tremendous Productivity

- > Impressive engine performance with high maximum torque
- > Three different milling drum speeds
- > Battery-powered hydraulic unit with additional functions
- > Automated water injection into the milling drum unit
- > Automatic WIDRIVE functions significantly reduce the need for operator intervention

10 Low Environmental Emissions

- > Engine models for EU Stage 3a / US EPA Tier 3 or for stringent EU Stage 5 emissions standards
- > Alternative engine station with additional exhaust gas purification via Diesel particulate filter
- > Minimized noise emissions through effective noise insulation and controlled fan speed

HIGH-PRECISION, INTUITIVE LEVEL PRO *PLUS* LEVELING SYSTEM

During milling operations, it's important to remove the layers of asphalt at the specified depth. WIRTGEN's intuitive **LEVEL PRO *PLUS*** leveling technology can be relied on to precisely maintain the specified milling depth.

Simple, Intuitive Operation

The **LEVEL PRO *PLUS*** leveling system developed especially for cold milling machines offers easy and intuitive one-hand operation using the rotary knob, and the menu can be configured as desired. **LEVEL PRO *PLUS*** stands out due to its extremely precise milling results.

Fully Integrated

The **LEVEL PRO *PLUS*** leveling system is fully integrated into the machine control system, enabling a high degree of automation.

Displacement Sensors

The reference line is scanned via heavy-duty displacement sensors built into the hydraulic side plate cylinders and displayed directly on the high-resolution **LEVEL PRO *PLUS*** control screen.

Hydraulic Scanning Sensor

A hydraulic cylinder sensor scans the reference height in front of the milling drum.

01 LEVEL PRO *PLUS* display

02 Machine control system

03 Cross-slope sensor

04 Hydraulic side plate cylinder with built-in displacement sensor

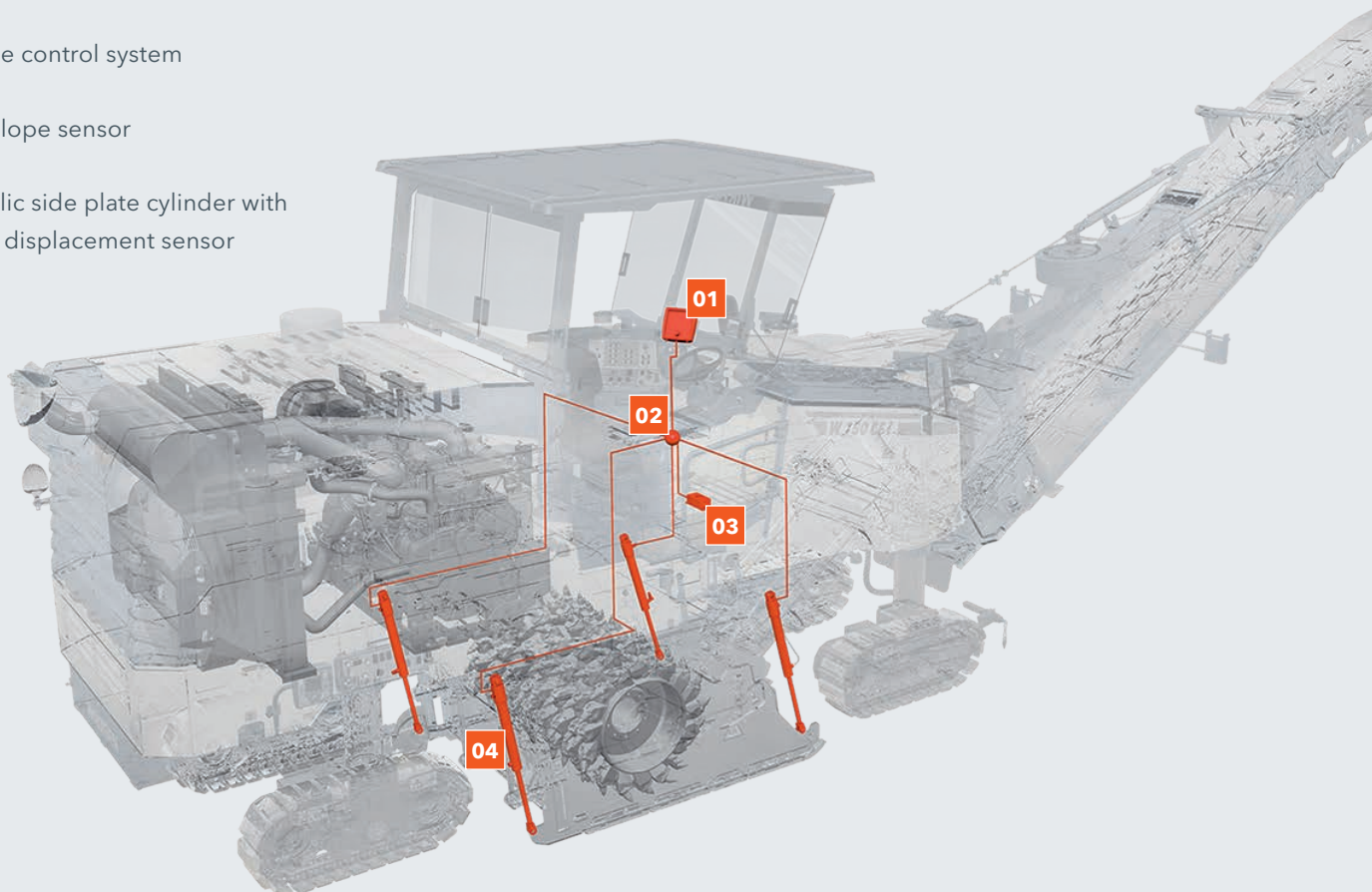

Always Makes the Grade

LEVEL PRO **PLUS**

Precise Leveling

Multiplex system

01 The leveling system uses a variety of different sensors.

02 LEVEL PRO PLUS is synonymous with perfect leveling quality at high operating speeds.

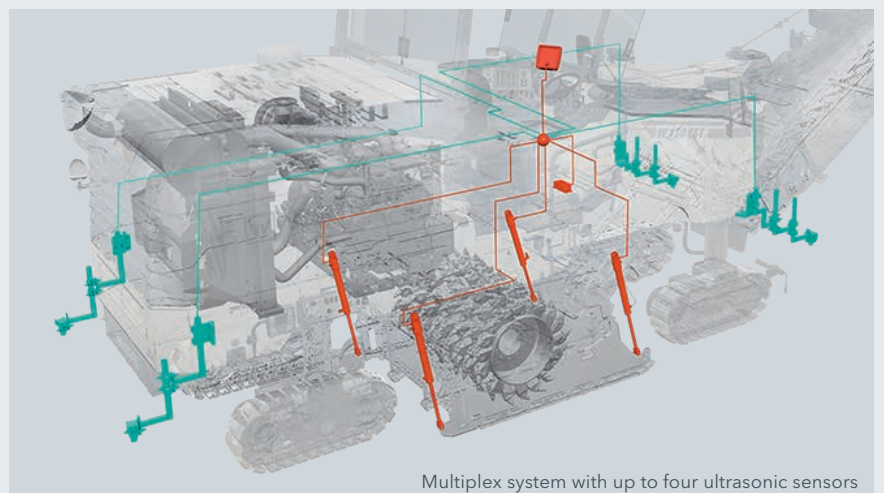
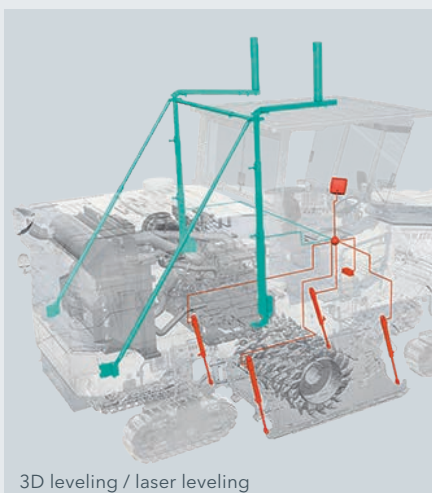
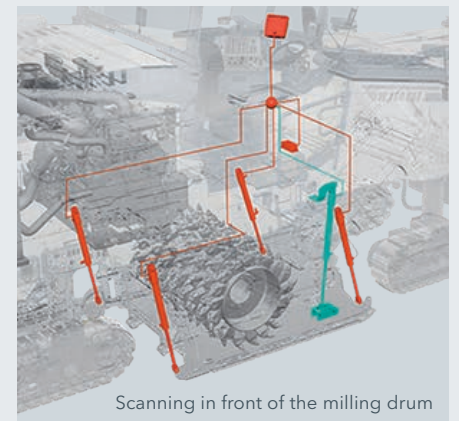
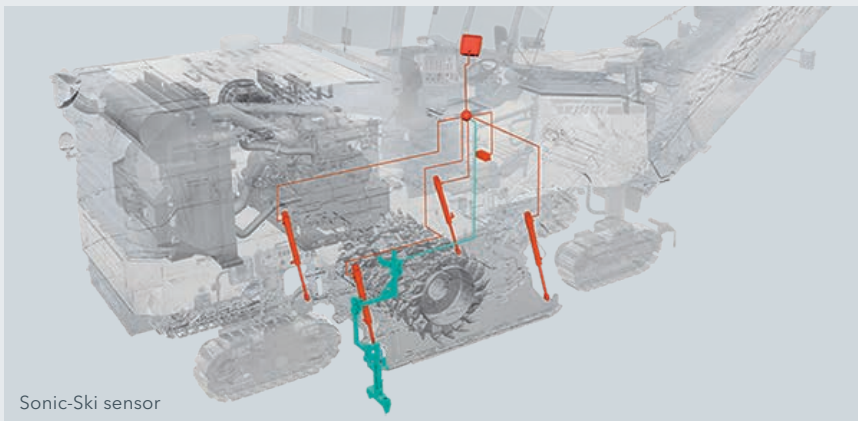

EFFICIENT MULTIFUNCTIONAL ARMREST

The compact milling machine's efficient multifunctional armrest not only speeds up processes and improves results, but also results in a more satisfied operator.

Ergonomically Designed Multifunctional Armrest

The multifunctional, individually adjustable armrest combines innovative design and ideal user-friendliness. Important information is displayed on the color control screen. The multifunctional armrest is also perfectly integrated into the WIRTGEN cold milling machine family's standardized user interface, guaranteeing productive operation right from the start.

Scraper Position

The scraper position is detected by a displacement sensor and shown on the control panel.

Job Data

Information like the weight and volume of the milled material, the size of milled areas, or the number of loaded trucks can be displayed automatically. This job data can be used to log daily performance.

Favorites Buttons

Four buttons can be programmed with twenty different functions as required by the operator.

01



Everything at Your Fingertips
Ergonomic multifunctional armrest

At a Glance
Color display shows essential information

- 01** The operator has everything under control with just one hand.
- 02** The ergonomically designed operator's platform with multifunctional arm-rest significantly increases the machine's productivity.



PERFECT VISIBILITY FOR HIGH-PRECISION WORK

01



Excellent Vision - Day and Night
Powerful floodlight system

Complete Concentration on the Milling Process
Optimal vision plus camera / monitor system



Clear visibility quickly proves its worth. The compact milling machine’s intelligently designed visibility concept makes the operator’s job much easier, resulting in improved milling results.

Adjustable Weather Canopy

The weather canopy with extension elements that can be pulled out to the side as well as sliding glass panes at the front and rear offer an ideal view of the surrounding area.

High-Quality Camera / Monitor System

The camera / monitor system consists of up to five cameras and a rugged monitor. The monitor displays, for example, the high-resolution image of the cameras at the end of the discharge conveyor showing the loading situation and, below the machine, the area in front of the milling drum housing.

Effective Headlights

Numerous intelligently arranged headlights - available in LED versions upon customer request - provide optimum visibility during operations at night.

01 Operations on job sites at night can be completed effortlessly thanks to optimum lighting.

02 The camera’s ability to see and display key working areas enhances performance and quality.



COMFORTABLE OPERATOR'S CABIN

A wide variety of different equipment features, individual adjustment options, and features that make operating the machine easier significantly enhance operator comfort. The result is maximum productivity on site.

Comfort Operator's Seat

The ergonomically designed, swiveling comfort seat with seat heater allows the operator to work in a relaxed manner. It also helps provide the operator an excellent view to the side and rear of the machine.

"Welcome and Ho Gome" Lighting

The access ladder and operator's platform can be brightly illuminated when approaching and walking away from the machine.

Weather Protection

Additional wind and weather protection elements on the operator's platform protect the operator from exposure to rain and wind.

Additional Controls for the Ground Crew

Practical operating functions can be used to rotate the milling drum for pick changes or to activate scanning in front of the milling drum.

01



01 The machine's high standards of comfort enable fatigue-free, productive work.



Protection in All Weathers

Additional wind and weather protection features

Stress-Free Operating

Comfortable operator's seat

FAST MANEUVERING WITH HIGH TRACTION

PTS

Automatic parallel to-surface machine alignment

High Travel Speed

Fast relocation to next job

01



The W 150 CF(i) quickly and effortlessly compensates for unevenness or difficult ground. It can also be quickly relocated from one site to another.

Electronic Track Chain Control

The ISC electronic track chain control system keeps track pad wear to a minimum and ensures the machine has optimum traction on any surface.

7.5 km/h Travel Speed

The machine's maximum speed of 7.5 km/h ensures that jobs are completed particularly quickly.

Automatic Parallel Machine Alignment

The further optimized PTS (parallel to surface) with quadruple pendulum system makes it possible to quickly and reliably adjust the machine's height parallel to the ground and ensure that it is perfectly level. PTS significantly reduces the operator's workload by eliminating the need for manual readjustment.

"Stop-and-Go" Display

The "stop-and-go" system, which can be folded out hydraulically, allows the operator to visually and silently communicate with the truck driver in front.



01 The quadruple pendulum axle quickly and dynamically compensates for unevenness.

02 The compact milling machine always aligns itself parallel to the road surface.



LIGHT AND MANEUVERABLE MACHINE



01

01 The machine's maneuverability makes operations on narrow job sites easier.

02 The large turning angles of all crawler units make tight turning radii possible.

Time-Saving Repositioning

Extremely large steering lock

Absolute Steering Precision

Fingertip steering

02



The W 150 CF(i) is a champion in tight bends, traffic circles, or urban areas, making small turning radii and high-precision milling possible in any job site situation.

Large Steering Angles

The large steering angles to the left and right guarantee small turning circles and thus rapid maneuvering, even in tight spaces.

Precision Steering

The highly responsive hydraulic steering system allows the operator to steer the machine precisely and smoothly, including via the right-hand multifunctional armrest.

Light Machine with Additional Weight

The machine's low net weight and variable ballasting weight of up to 900 kg make a high operating weight, optimum traction, and simplified transport possible.

Incremental Height Adjustment

The additional height adjustment feature on the left-hand control panel allows the operator to precisely adjust the milling depth in increments of 1 mm or 5 mm.

IMPRESSIVE MILLING PERFORMANCE IN A VARIETY OF APPLICATIONS



The milling drum unit features a variety of valuable, innovative features, and can achieve milling depths of up to 330 mm.

Rapid Pick Changes

The hydraulically operated milling drum rotation device and pick ejector make it

easier to change picks – even when the engine is switched off.

Hydraulically Lifting Side Plates with Proactive Floating Position

Overload sensors on the left and right side plates cause them to lift briefly to

HT22 Toolholder System in Detail

01 Innovative centering marks on the tool contact surface in combination with **GENERATION X²** picks for maximum toolholder service life right from the start

02 Significantly larger, more durable, and self-centering contact surfaces on the top and bottom parts significantly extend the service life of the milling drum

03 Increased wear volume in the shoulder section improves protection of the toolholder base when milling abrasive materials

04 Reduced maintenance requirements due to longer intervals between torque inspections of the quick-change toolholder bolts (every 500 hours)

05 Optimized shaft geometry with additional improved thermal processing to withstand extreme stress

06 Protective plug prevents bolt head from getting dirty

07 Heavy-duty retaining bolt

08 Seal between top and bottom part allows top part to be easily removed / inserted

09 Bottom part covers top part completely for maximum protection

10 Extra-large contact surface between top part and bottom part for longer bottom part service life

11 Optimized welded joint with increased strength and flexibility for optimum pick rotation

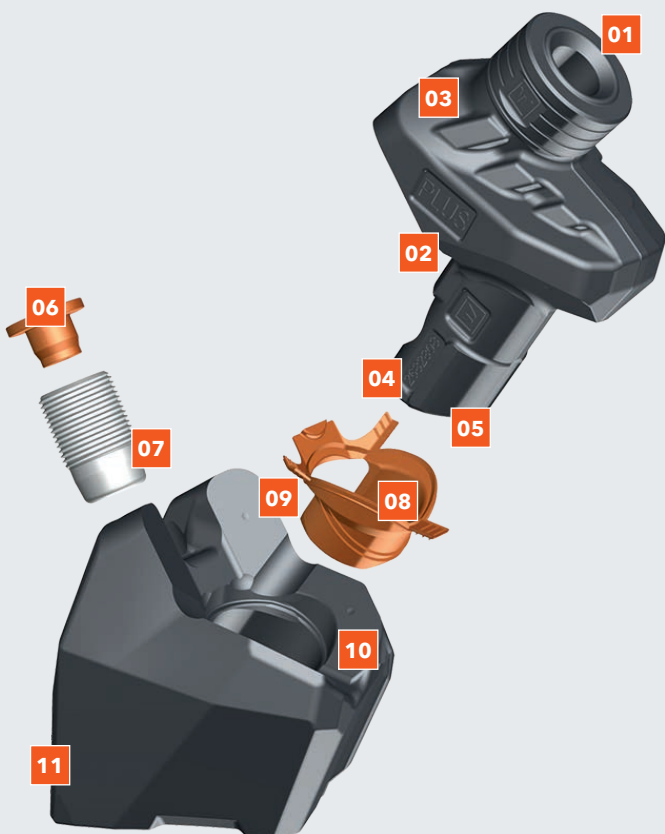

Long Servicing Intervals
HT22

Greater Versatility and Higher Machine Utilization Rates
Milling width 1.8 m

prevent them from sinking into soft ground. Screw-on wear protection segments also extend the side plates' service life.

Automatic Scraper Lifting

Overload sensors protect the milling drum unit from damage by triggering the scraper to lift briefly, such as to avoid obstacles or uneven ground.

HT22 Toolholder System

The extremely wear-resistant HT22 quick-change toolholder system (standard) minimizes downtimes and increases the service life of the entire milling drum.

Complete FCS Package for FB1500

FB600, FB900, FB1200, and FB1500 milling drums are available as complete FCS packages for the FB1500 milling drum unit. The milling drum can be changed quickly thanks to the easily-accessible right-hand side panel.

Alternative Milling Width of 1.8 m

For increased productivity and greater surface coverage, the compact milling machine can be equipped with 1.8 m wide milling drums using a housing extension.



01 The W 150 CF(i) with a 1.8 m wide milling drum achieves increased daily output rates.

W 150 CF(i) with 1.5 m Drum Unit

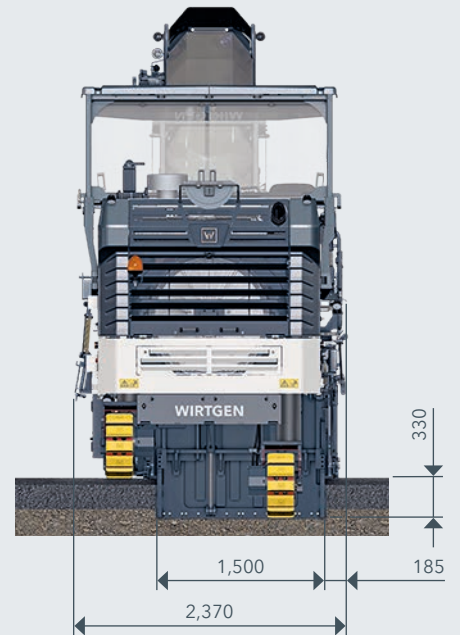

Dimensions in mm

Milling Drum

Milling width: 1,500 mm
Milling depth: 0-330 mm
Tool spacing: 15 mm



W 150 CF(i) with 1.8 m Drum Unit

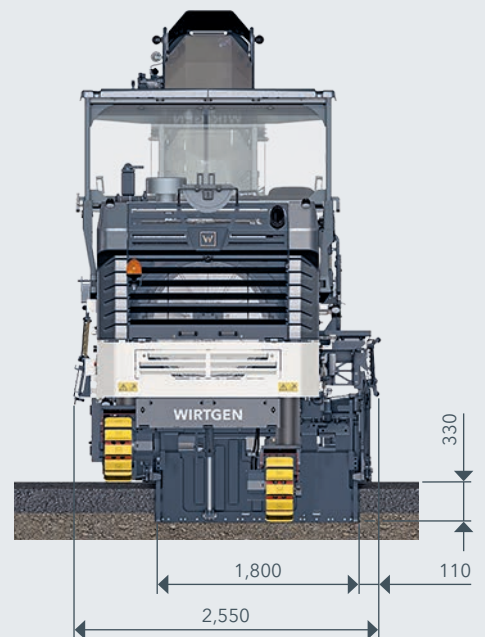

Dimensions in mm

Milling Drum

Milling width: 1,800 mm
Milling depth: 0-330 mm
Tool spacing: 18 mm



HIGH LOADING VOLUME WITH MAXIMUM FLEXIBILITY

Maximum performance and outstanding flexibility are also required when transporting the milled material in order to complete the milling process smoothly.

Wide Conveyor Swing Angles

Wide conveyor swing angles of 60° to both sides make it possible to load material even in difficult situations, e.g. in intersections or turning areas.

Two Conveyor Swing Speeds

The discharge conveyor can swing slowly to ensure precise loading of the milled material or quickly to optimize the entire milling process.

VCS Extraction System

VCS improves air quality and visibility in the machine operator's and ground crew's working area. In addition, the optimized design of the VCS suction channel reduces the amount of cleaning required.

Hydraulic Folding Conveyor

The hydraulic folding conveyor can be folded away quickly for easy transport and to adapt to site conditions.

Quick-Change Coupling

The innovative quick-change coupling ensures that the hydraulic connections can be easily connected when mounting / removing the discharge conveyor.

Fast Offloading of Milled Material

Powerful loading performance

Precision Results - Fast Responses

Two slewing speeds

01



Increased Loading Performance

A 15 % increase in conveyor speed and 28 % larger belt cleat profile compared to the previous model significantly improve loading performance.

- 01 High, variable conveyor speed and wide conveyor swing angles ensure that the milled material can be loaded with maximum flexibility.
- 02 The wide conveyor swing angle of up to 60° on both sides simplifies milling in narrow spaces.
- 03 The folding conveyor reduces the machine's transport length.



MAXIMUM EFFICIENCY FOR TREMENDOUS PRODUCTIVITY

The most powerful cold milling machine in the compact class stands out thanks to its impressive engine performance. Its productivity is enhanced further by features tailored to site requirements.

Impressive Engine Performance

The state-of-the-art Diesel engine offers tremendous engine power with high maximum torque. This guarantees rapid, productive operations, even at the maximum milling depth.

Three Different Milling Drum Speeds

Three different milling drum speeds make it possible to achieve unparalleled milling performance in a wide range of applications.

Hydraulic Unit

The extended electrohydraulic unit powers features such as the milling drum rotation device, the pick ejector when the engine is switched off, and emergency functions, increasing the machine's flexibility on the job site.

01



More Power

Powerful diesel engine

Powerful, Cost-Efficient, and Sustainable

Three different milling drum speeds

Automatic Water Injection

The amount of water injected to cool the picks increases automatically relative to the increase in engine load. Water consumption can also be directly adjusted electrically from the operator's platform.

Reduced Operator Intervention

The WIDRIVE machine control system offers numerous automated features to make the operator's daily work easier. In addition, WIDRIVE pays for itself through lower Diesel consumption and increased daily output rates.



01 - 02 The WIDRIVE machine control system and the compact milling machine's simple operating concept result in high daily output rates.



LOW ENVIRONMENTAL EMISSIONS

Low Diesel consumption and low noise levels protect both the operator and the environment. Ultimately, the environmentally friendly machine technology used in the W 150 CF(i) cuts costs and enhances operator performance.

Two Engine Models

The engine technology used in the W 150 CF meets EU Stage 3a / US EPA Tier 3 emissions standards. The W 150 CFi meets the stringent requirements of the EU Stage 5 emissions standard.

Optional Built-in Diesel Particulate Filter

The optional Diesel particulate filter that can be equipped during the initial configuration of the W 150 CFi fulfills even more stringent exhaust gas requirements, if required.

Minimal Noise Level

Optimized machine settings and more effective noise insulation significantly reduce noise emissions. The cooling system with temperature-controlled fan speed also helps reduce noise emissions.

W 150 CFi Exhaust Aftertreatment

The Diesel engine meets the stringent requirements of the EU Stage 5, currently the highest emission standard.

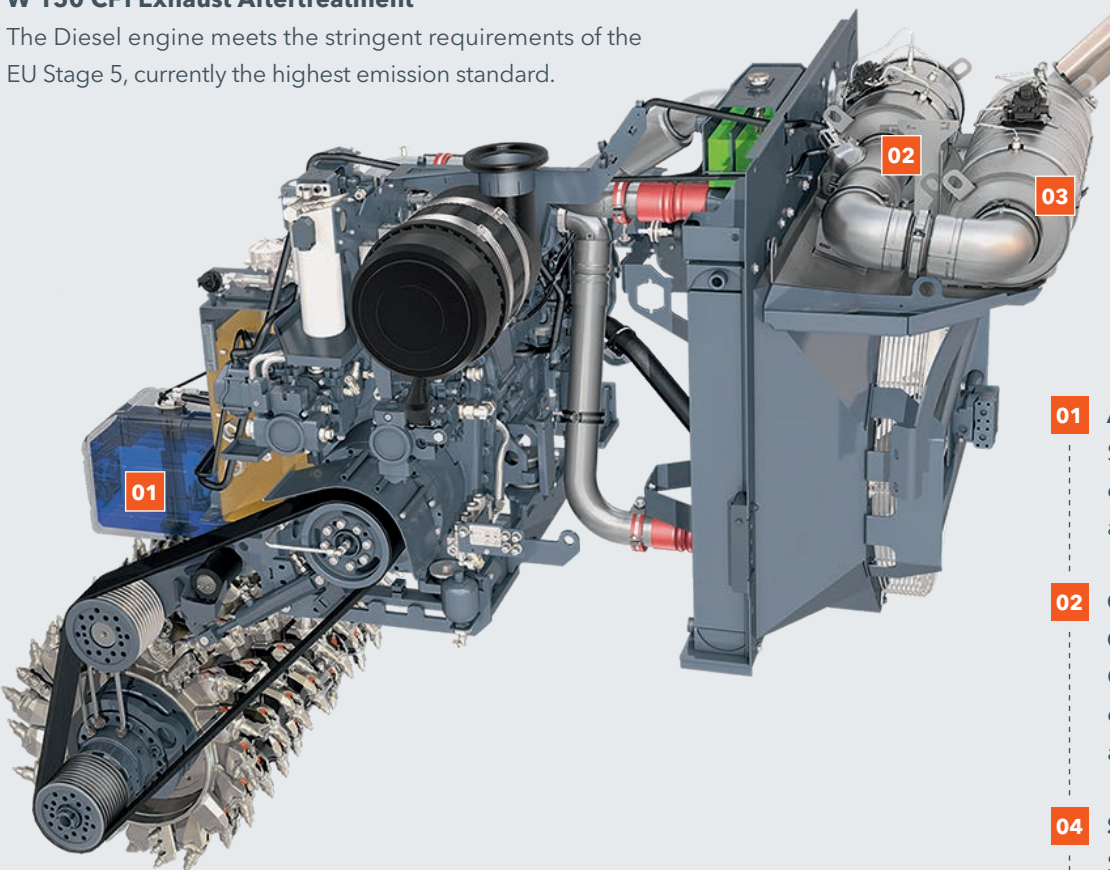

01

01 AdBlue® / DEF-Tank
Storage container for Diesel exhaust fluid with easily accessible filler opening.

02 Oxidation Catalytic Converter
Catalytic converter for the oxidation of hydrocarbons and carbon monoxide.

04 SCR Catalytic Converter
SCR catalytic converter for reducing nitrogen oxides by adding a special Diesel exhaust fluid.

Economical and Environmentally Compatible

EU Stage 5 exhaust emission standard and low noise emissions

01 The engine used in the W 150 CFi is equipped with an oxidation catalytic converter and an SCR catalytic converter for effective exhaust gas purification.

02 Excellent access to components makes servicing the machine easy.

03 The sharp increase in torque guarantees outstanding milling performance.



03

W 150 CF
(EU Stage 3a / US EPA Tier 3)
Engine Characteristics

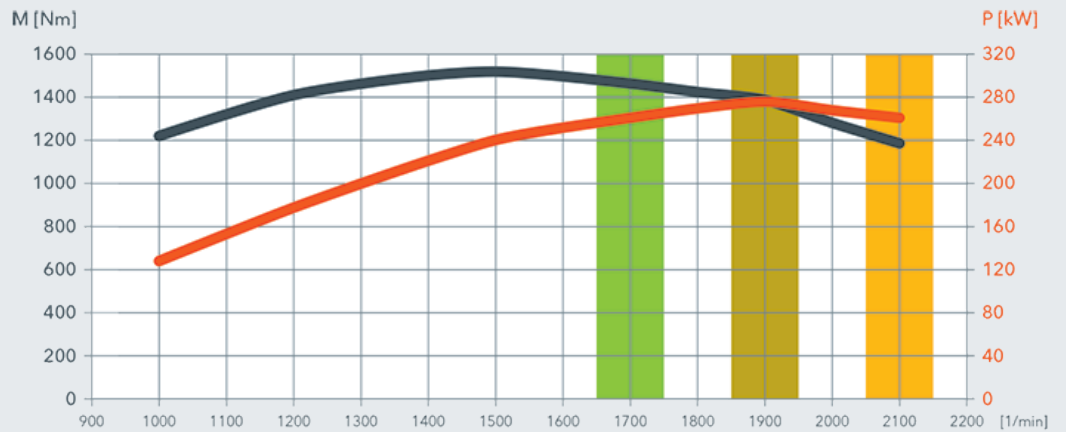

W 150 CFi
(EU Stage 5)
Engine Characteristics

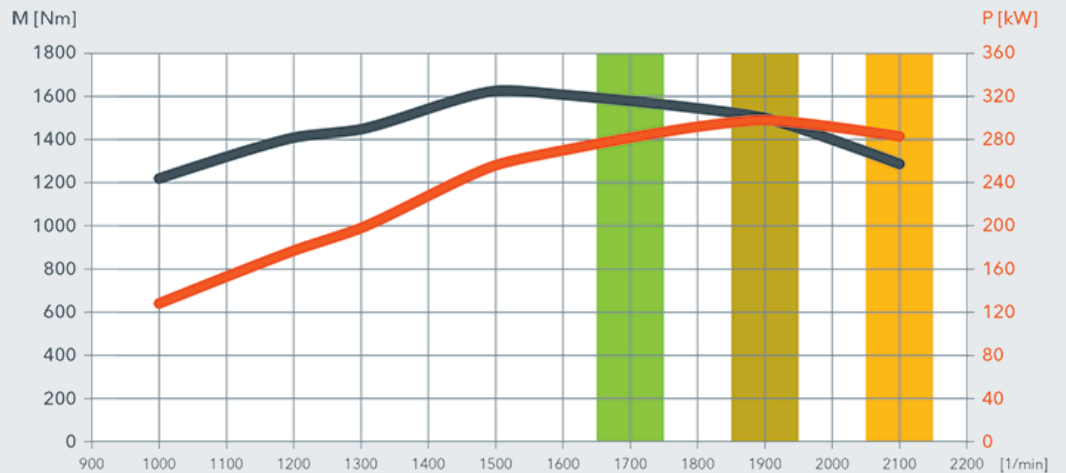

— = Engine power — = Torque ■ Engine speed = 1,700 rpm ■ Engine speed = 1,900 rpm ■ Engine speed = 2,100 rpm





The most powerful cold milling machine in the compact class is particularly suitable for large-scale job sites where space is limited, such as in urban areas. FCS enables the use of different milling drums up to a maximum working width of 1.8 m for greater flexibility and machine utilization. The machine's low weight and centrally positioned milling drum unit ensure that its weight is ideally distributed.



TECHNICAL SPECIFICATIONS	W 150 CF	W 150 CFi
Milling Drum		
Standard milling width	1,500 mm	
Optional milling width	1,800 mm	
Milling depth ¹⁾	0 - 330 mm	
Cutting diameter	980 mm	
Engine		
Manufacturer	CUMMINS	CUMMINS
Type	QSL 9	QSL 9
Cooling	Water	Water
Number of cylinders	6	6
Rated power at 2,100 rpm	261 kW / 350 hp / 355 PS	283 kW / 380 hp / 385 PS
Maximum power at 1,900 rpm	276 kW / 370 hp / 375 PS	298 kW / 400 hp / 405 PS
Operating power at 1,600 rpm	250 kW / 335 hp / 340 PS	270 kW / 362 hp / 367 PS
Displacement	8.9 l	8.9 l
Fuel consumption at rated power at mix of job site operations	72 l/h 29 l/h	75 l/h 30 l/h
Sound power level in accordance with EN 500-2, engine operator's platform	≤ 105 dB(A) ≥ 86 dB(A)	≤ 105 dB(A) ≥ 83 dB(A)
Emissions standard	EU Stage 3a / US EPA Tier 3	EU Stage 5
Electrical System		
Power supply	24 V	
Tank Capacities		
Fuel tank	810 l	
AdBlue® / DEF ²⁾	-	50 l
Hydraulic oil	120 l	
Water	2,250 l	
Driving Performance		
Max. milling speed	0 - 40 m/min (2.4 km/h)	0 - 40 m/min (2.4 km/h)
Max. travel speed	0 - 125 m/min (7.5 km/h)	0 - 125 m/min (7.5 km/h)
Crawler Units		
Track chains front / back (L x W x H)	1,330 x 260 x 550 mm	
Loading of Milled Material		
Belt width of primary conveyor	650 mm	
Belt width of discharge conveyor	600 mm	
Theoretical capacity of discharge conveyor	233 m ³ /h	

TECHNICAL SPECIFICATIONS	W 150 CF	W 150 CFi
Weight of Basic Machine		
Empty weight of machine without fluids	19,000 kg	19,300 kg
Operating weight, CE ³⁾	20,550 kg	20,850 kg
Maximum operating weight (full tanks, full range of equipment)	24,850 kg	25,200 kg
Weight of Tank Contents		
Water	2,250 kg	2,250 kg
Fuel (0.83 kg/l)	670 kg	670 kg
AdBlue® / DEF ²⁾ (1.1 kg/l)	-	55 kg
Additional Weight		
Operator and Tools		
> Machine operator		75 kg
> 5 pick containers		125 kg
> Vehicle tool kit		30 kg
Optional Milling Drum Units Instead of Standard		
> Milling drum housing FB1500 FCS-L		270 kg
> Milling drum housing FB1500 FCS		380 kg
> Milling drum housing FB1800 FCS-L		800 kg
Optional Milling Drums Instead of Standard		
> FB1500 FCS milling drum, HT22 Plus LA15 with 136 picks		20 kg
> FCS milling drum FB1500, HT22 Plus LA18 with 118 picks		-70 kg
> FCS milling drum FB1500, HT22 Plus LA8 with 210 picks		380 kg
> FCS milling drum FB1500, HT5 LA6X2 with 512 picks		450 kg
> FCS milling drum FB1500, HT22 Plus LA25 with 102 picks		-400 kg
> FCS milling drum FB1800, HT22 Plus LA18 with 135 picks		190 kg
Optional Additional Equipment		
> Weather canopy instead of standard		450 kg
> Hydraulic short folding conveyor instead of standard		-45 kg
> VCS extraction system		125 kg
> Leveling boom		250 kg
> Additional weight at the rear		900 kg

¹⁾ The maximum milling depth may deviate from the value indicated due to tolerances and wear.

²⁾ AdBlue® is a registered trademark of the German Association of the Automotive Industry (VDA).

³⁾ Machine weight, half-full tanks, vehicle tool kits, machine operator, excluding optional equipment

SIDE VIEW / TOP VIEW W 150 CF(i)

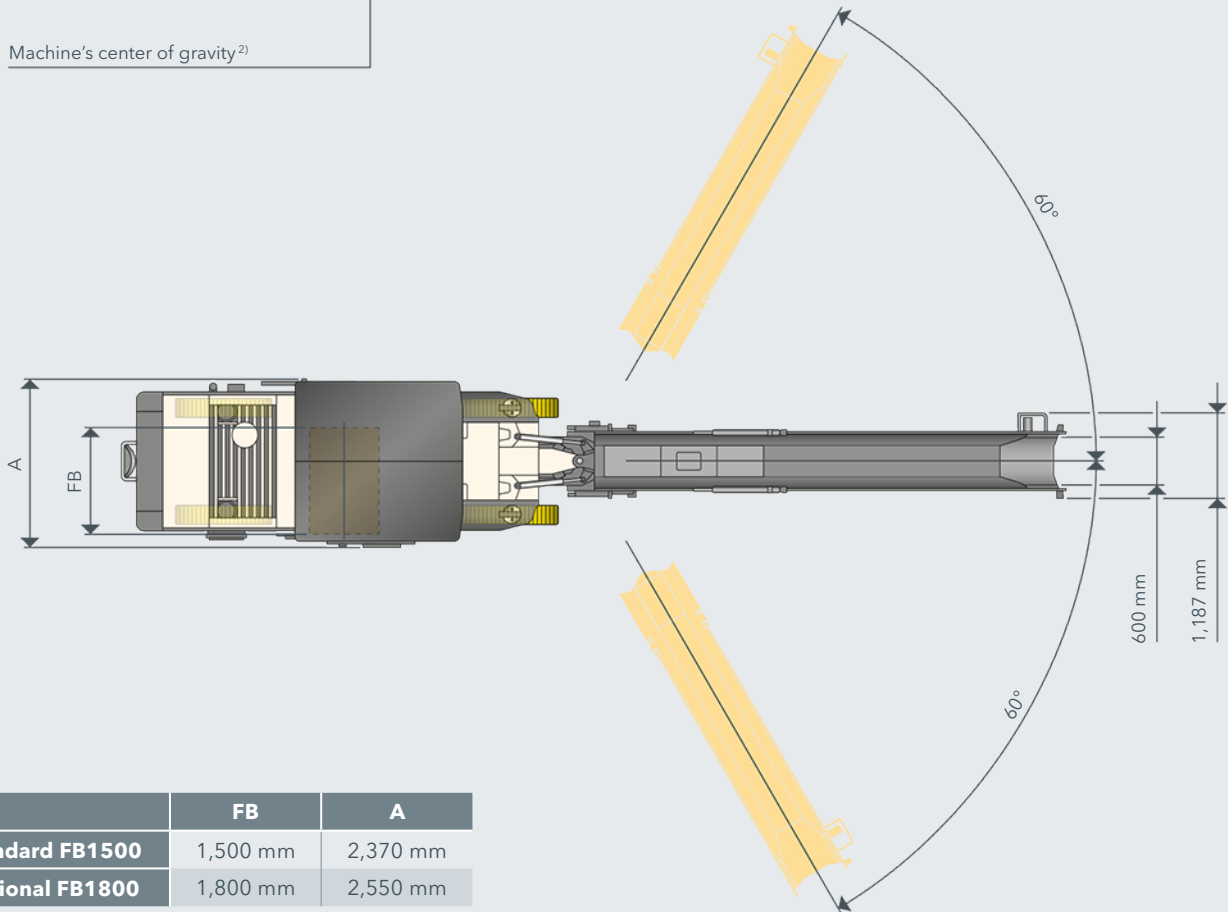
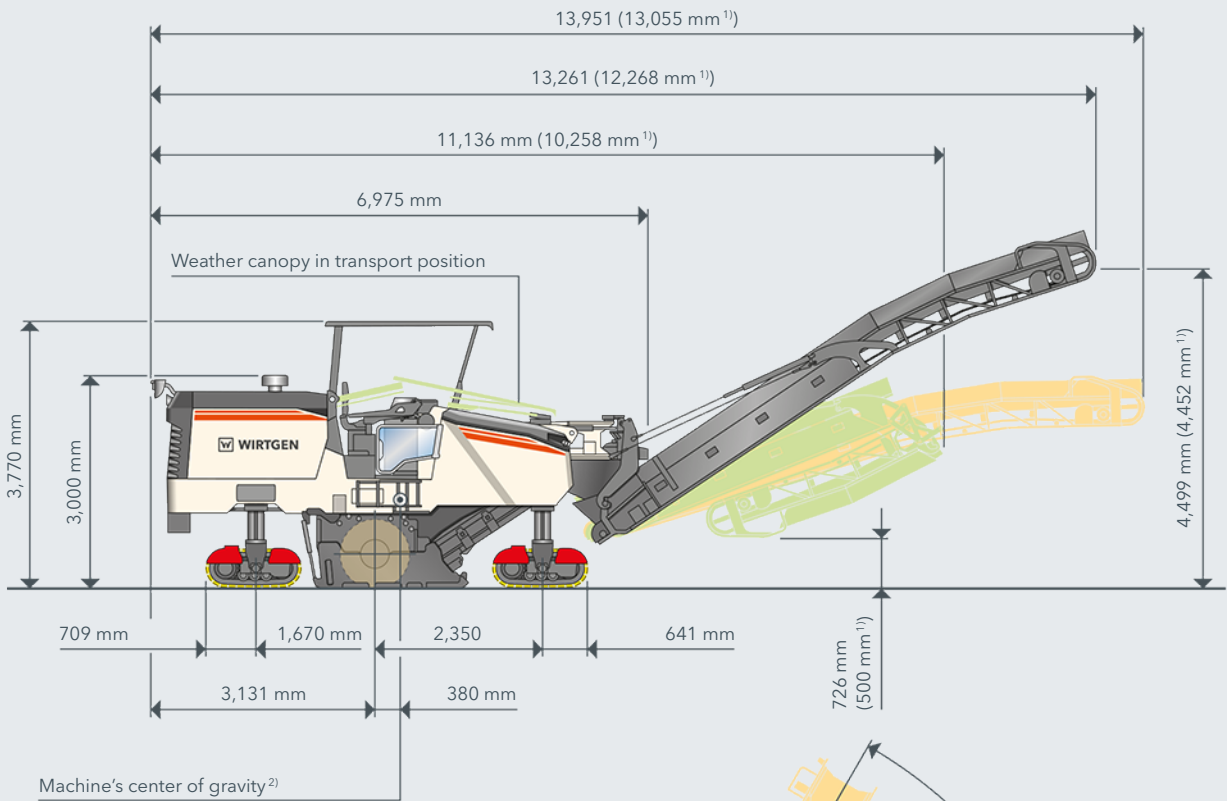

	FB	A
Standard FB1500	1,500 mm	2,370 mm
Optional FB1800	1,800 mm	2,550 mm

¹⁾ Short folding discharge conveyor

²⁾ Based on operating weight, CE with conveyor folded out

MILLING RADIUS W 150 CF(i) AT MILLING DEPTH OF 150 MM

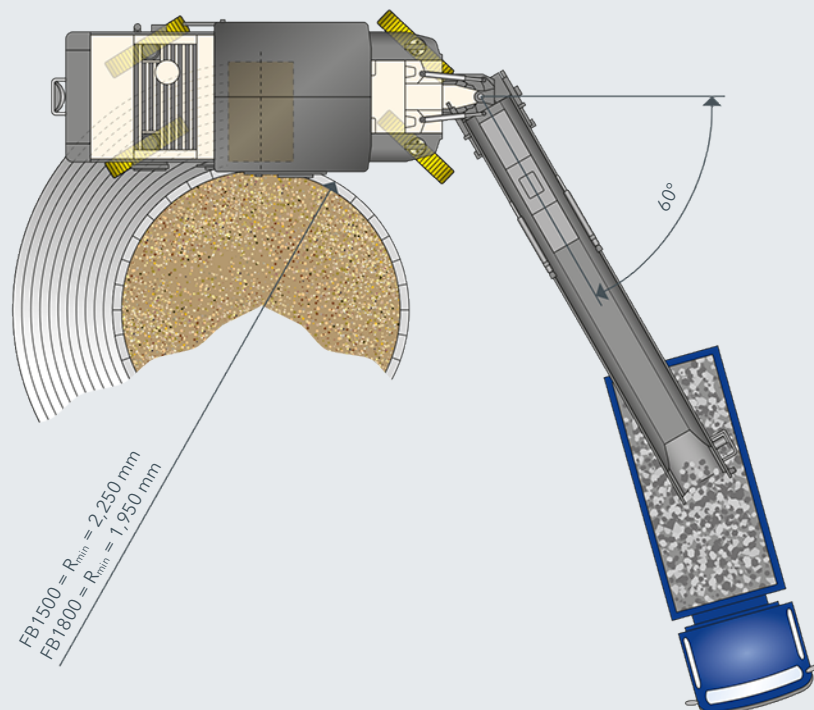
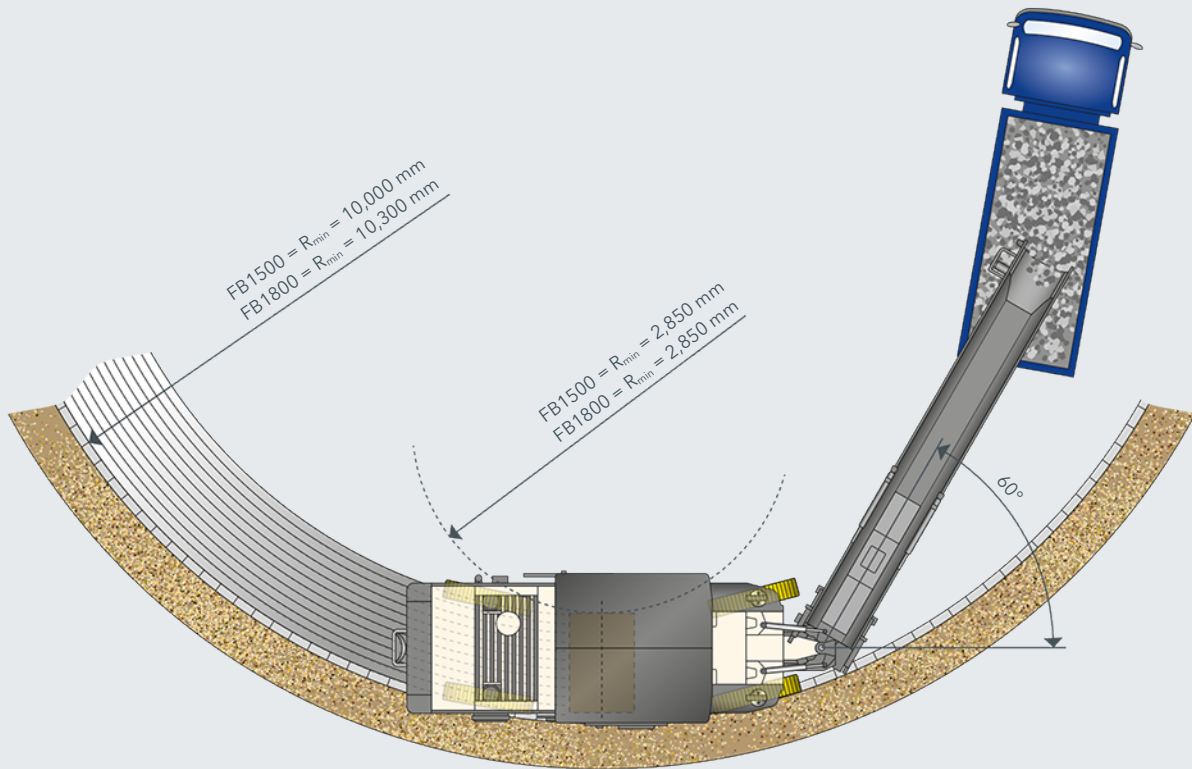

STANDARD EQUIPMENT	W 150 CF	W 150 CFi
Basic Machine		
> Base machine with engine	■	—
> Base machine with engine including exhaust gas aftertreatment according to EU Stage 5 consisting out of a diesel oxidation catalyst (DOC) and a diesel particulate filter (DPF)	—	■
> Machine chassis with wasp waist on the right side (zero edge)	■	■
> Electrohydraulically opening engine cowling	■	■
> Radiator with temperature-dependent fan speed	■	■
> Additional control switch for scraper blade, bottom right	■	■
> Elastically mounted engine station with low vibration and low noise	■	■
> Three milling drum rotation speeds with electric on/off function 106 rpm - 96 rpm - 86 rpm	■	■
> Air compressor system	■	■
Milling Drum Unit		
> The right-hand side of the milling drum housing can be easily opened for maintenance or drum change	■	■
> Hydraulic material depressor with conveyor lifting function	■	■
> Hydraulically opening scraper plate with convenience locking	■	■
> Exchangeable wearing segments on the side plate	■	■
> Milling drum housing FB1500	□	□
Milling Drums		
> Milling drum FB1500 HT22 Plus LA15 with 136 picks	□	□
Loading of the Milled Material		
> Discharge conveyor slewing angle left 60 degrees - right 60 degrees	■	■
> Hydraulically foldable discharge conveyor with two swing speeds, including adjustable conveyor speed for precise loading	■	■
> Machine with hydraulic standard coupling for the discharge conveyor	□	□
> Discharge conveyor, 8,150 mm long, 600 mm wide, with hydraulic folding device	□	□
Machine Control and Leveling System		
> LEVEL PRO PLUS leveling system right and left	■	■
> RAPID SLOPE cross-slope sensor for LEVEL PRO ACTIVE leveling system	■	■
> Load-dependent advance control	■	■
> 4-track drive with manually activated, electronic anti-slip control	■	■
> 4 selectable steering modes	■	■
> Automatic water management	■	■
> Automatic engine speed control	■	■
Operator's Platform		
> Convenient control panel with practical switches	■	■
> Multifunctional armrest including color operating display for one-handed operation of most machine functions	■	■
> Digital multi-function display for all important operating conditions	■	■
> Scraper height indicator on control panel	■	■
> Operating panel nighttime lighting	■	■
> Robust anti-vandalism protection for the controls	■	■
> Adjustable steering wheel position	■	■
> Optimally positionable operator's seat	■	■
> Footstep right and left with conveniently folding ladder	■	■
> Two mirrors front, one mirror middle and one mirror in rear area of the machine	■	■
> Standard operator's seat	□	□

STANDARD EQUIPMENT	W 150 CF	W 150 CFi
Track Unit and Height Adjustment		
> Jog mode for height adjustment	■	■
> Fourfold full-floating axle for high machine stability	■	■
> PTS - automatic alignment of the machine parallel to the pavement surface	■	■
> ISC - intelligent track speed control including hydraulic four-track drive	■	■
> Reversing with the milling drum rotating. Simple and fast maneuvering	■	■
> Equipped with extremely wear-resistant 2-piece polyurethane track pads	■	■
Miscellaneous		
> Large tool package	■	■
> Generously sized water and diesel tanks	■	■
> Total of 3 EMERGENCY STOP switches at sensible positions on the machine	■	■
> "Welcome-and-Go-Home-Light" feature including LED lighting in the area of the operator's platform and access	■	■
> Pre-fitting for installing the WITOS FleetView control unit	■	■
> European type certification, EuroTest mark and CE conformity	■	■
> Standard film coating in RAL 9001 (cream)	□	□
> WITOS - professional telematics solution for machine operation and service optimization	□	□
> Halogen / LED lighting system including rotating beacon	□	□
> Electro-hydraulic unit	□	□

■ = Standard equipment

□ = Standard equipment, can be replaced with optional equipment if desired

□ = Optional equipment

OPTIONAL EQUIPMENT	W 150 CF	W 150 CFi
Milling Drum Unit		
> Milling drum housing FB1500 FCS-L	<input type="checkbox"/>	<input type="checkbox"/>
> Milling drum housing FB1500 FCS	<input type="checkbox"/>	<input type="checkbox"/>
> Milling drum housing FB1800 FCS-L	<input type="checkbox"/>	<input type="checkbox"/>
> Milling drum housing FB1200 FCS	<input type="checkbox"/>	<input type="checkbox"/>
> Overload sensor on the scraper	<input type="checkbox"/>	<input type="checkbox"/>
> Active floating position for the side plates, left and right	<input type="checkbox"/>	<input type="checkbox"/>
> Milling drum rotation device	<input type="checkbox"/>	<input type="checkbox"/>
Milling Drums		
> FCS milling drum FB1500 HT5 LA6X2 with 512 picks	<input type="checkbox"/>	<input type="checkbox"/>
> FCS milling drum FB1500 HT22 Plus LA8 with 210 picks	<input type="checkbox"/>	<input type="checkbox"/>
> FCS milling drum FB1500 HT22 Plus LA15 with 136 picks	<input type="checkbox"/>	<input type="checkbox"/>
> FCS milling drum FB1500 HT22 Plus LA18 with 118 picks	<input type="checkbox"/>	<input type="checkbox"/>
> FCS milling drum FB1500 HT22 Plus LA25 with 102 picks	<input type="checkbox"/>	<input type="checkbox"/>
> FCS milling drum FB1800 HT5 LA6X2 with 608 picks	<input type="checkbox"/>	<input type="checkbox"/>
> FCS milling drum FB1800 HT22 Plus LA8 with 248 picks	<input type="checkbox"/>	<input type="checkbox"/>
> FCS milling drum FB1800 HT22 Plus LA18 with 135 picks	<input type="checkbox"/>	<input type="checkbox"/>
> FCS milling drum FB1800 HT22 Plus LA25 with 114 picks	<input type="checkbox"/>	<input type="checkbox"/>
> FCS milling drum FB1200 HT5 LA6X2 with 410 picks	<input type="checkbox"/>	<input type="checkbox"/>
> FCS milling drum FB1200 HT22 Plus LA8 with 174 picks	<input type="checkbox"/>	<input type="checkbox"/>
> FCS milling drum FB1200 HT22 Plus LA15 with 109 picks	<input type="checkbox"/>	<input type="checkbox"/>
> FCS milling drum FB1200 HT22 Plus LA25 with 87 picks	<input type="checkbox"/>	<input type="checkbox"/>
> FCS milling unit FB600 HT22 Plus LA12 with 79 picks	<input type="checkbox"/>	<input type="checkbox"/>
> FCS milling unit FB900 HT22 Plus LA15 with 102 picks	<input type="checkbox"/>	<input type="checkbox"/>
> FCS milling unit FB1200 HT22 Plus LA15 with 109 picks	<input type="checkbox"/>	<input type="checkbox"/>
Loading of the Milled Material		
> Machine with hydraulic quick-change coupling for the discharge conveyor	<input type="checkbox"/>	<input type="checkbox"/>
> Shortened discharge conveyor, 7,250 mm long, 600 mm wide, with hydraulic folding device	<input type="checkbox"/>	<input type="checkbox"/>
> VCS extraction system	<input type="checkbox"/>	<input type="checkbox"/>
> Signal lights for visual "stop" and "go" instructions for the truck driver	<input type="checkbox"/>	<input type="checkbox"/>
> Additional storage compartment on the discharge conveyor	<input type="checkbox"/>	<input type="checkbox"/>

OPTIONAL EQUIPMENT	W 150 CF	W 150 CFi
Machine Control and Leveling System		
> SONIC SKI sensor for LEVEL PRO PLUS leveling system	<input type="checkbox"/>	<input type="checkbox"/>
> Scanning in front of the milling drum unit	<input type="checkbox"/>	<input type="checkbox"/>
> Additional operating display LEVEL PRO PLUS	<input type="checkbox"/>	<input type="checkbox"/>
> Multiplex pre-fitting comprising 4 sensor sockets and holder	<input type="checkbox"/>	<input type="checkbox"/>
> 3-way multiplex system, right, including 2 ultrasonic sensors	<input type="checkbox"/>	<input type="checkbox"/>
> 3-way multiplex system, right and left, including 4 ultrasonic sensors	<input type="checkbox"/>	<input type="checkbox"/>
> Level control 3D leveling pre-equipment	<input type="checkbox"/>	<input type="checkbox"/>
> Basic equipment laser leveling without laser transmitter	<input type="checkbox"/>	<input type="checkbox"/>
> Milling depth measurement and display in the LEVEL PRO PLUS display	<input type="checkbox"/>	<input type="checkbox"/>
> Job data acquisition in the control display	<input type="checkbox"/>	<input type="checkbox"/>
Operator's Platform		
> Comfort operator's seat including seat heating	<input type="checkbox"/>	<input type="checkbox"/>
> Weather canopy with electro-hydraulic fold-down feature	<input type="checkbox"/>	<input type="checkbox"/>
> Additional control unit for operating the machine from the ground, left	<input type="checkbox"/>	<input type="checkbox"/>
> Heating operator's platform	<input type="checkbox"/>	<input type="checkbox"/>
Track Unit and Height Adjustment		
> Increased traveling speed (up to 7.5 km/h)	<input type="checkbox"/>	<input type="checkbox"/>
> Precision steering by pushbuttons	<input type="checkbox"/>	<input type="checkbox"/>
Miscellaneous		
> Film coating according to the customer's wishes	<input type="checkbox"/>	<input type="checkbox"/>
> Model without WITOS	<input type="checkbox"/>	<input type="checkbox"/>
> High-power lighting system LED including rotating beacon	<input type="checkbox"/>	<input type="checkbox"/>
> Extended electro-hydraulic unit	<input type="checkbox"/>	<input type="checkbox"/>
> Additional weight 900 kg	<input type="checkbox"/>	<input type="checkbox"/>
> Milling drum assembly trolley to FB1500	<input type="checkbox"/>	<input type="checkbox"/>
> Electrical fuel filter preheating	—	<input type="checkbox"/>
> Pre-equipped for LED lighting balloons	<input type="checkbox"/>	<input type="checkbox"/>
> Hydraulic filling pump for water tank	<input type="checkbox"/>	<input type="checkbox"/>
> Powerful high-pressure water cleaner, 150 bar, 15 l/min	<input type="checkbox"/>	<input type="checkbox"/>
> Pneumatic hammer with pick extractor/insert	<input type="checkbox"/>	<input type="checkbox"/>
> Hydraulically driven pick extractor drift	<input type="checkbox"/>	<input type="checkbox"/>
> Additional folding seat for pick change with storage compartment	<input type="checkbox"/>	<input type="checkbox"/>
> Diesel tank filling pump with 5.00 m suction hose	<input type="checkbox"/>	<input type="checkbox"/>
> Monitor system with 2 cameras and screen	<input type="checkbox"/>	<input type="checkbox"/>
> Monitor system with 5 cameras and 2 screens	<input type="checkbox"/>	<input type="checkbox"/>
> LED lighting balloon, 24 volt	<input type="checkbox"/>	<input type="checkbox"/>
> License plate holder with LED lighting	<input type="checkbox"/>	<input type="checkbox"/>
> Large storage compartment at the rear of the machine	<input type="checkbox"/>	<input type="checkbox"/>

■ = Standard equipment

▒ = Standard equipment, can be replaced with optional equipment if desired

□ = Optional equipment

**WIRTGEN GmbH**

Reinhard-Wirtgen-Str. 2
53578 Windhagen
Germany

P: +49 2645 131-0
F: +49 2645 131-392
M: info@wirtgen.com

 www.wirtgen.de



For further information, please scan the code.