

Innovation and Sustainability for a Wide Range of Milling Jobs

# COLD MILLING MACHINE

W 100 Fi | W 120 Fi | W 130 Fi



# INNOVATION AND SUSTAINABILITY FOR A WIDE RANGE OF MILLING JOBS

The front loader in the one-meter class is characterized by its outstanding performance and flexibility at working widths of 1.0 m, 1.2 m, or 1.3 m.

Compact dimensions and optimized machine weight make it ideal for a wide range of applications – including on job sites with limited space, such as in urban areas.

The variety of tool spacings and working widths offered by FCS milling drums further expands the range of possible applications.

The cutting-edge **LEVEL PRO ACTIVE** leveling system, the intuitive operating concept, and additional digital assistance systems enable efficient handling and precise milling results with only one operator.

The innovative **MILL ASSIST** machine control system ideally combines sustainable and efficient machine operation with high productivity.



# WIRTGEN COLD MILLING MACHINES

## SMALL MILLING MACHINES

- > Milling width up to 1,300 mm
- > Milling depth to 300 mm

## COMPACT MILLING MACHINES

- > Milling width up to 1,900 mm
- > Milling depth to 330 mm

## LARGE MILLING MACHINES

- > Milling width up to 4,400 mm
- > Milling depth to 350 mm



# OVERVIEW OF HIGHLIGHTS

## Perfectly Equipped

### COMFORT AND VISIBILITY

#### 01 Second-To-None Visibility

- > High-quality camera / monitor system with two or five cameras
- > Powerful complete LED lighting package
- > Operator's platform with lateral shift function for optimal vision along the zero side

#### 02 Perfect Comfort and Ergonomics

- > Platform design with perfect ergonomics for a high level of operator comfort and well-being
- > State-of-the-art operator's cabin for highest levels of comfort and productivity (optional)
- > The large 5-inch control screen in the multifunctional armrest displays essential information
- > Ergonomic access with automatic height adaptation
- > External control panel with frequently used machine functions
- > Ample storage space
- > Smart vandalism protection concept for control units



### ASSISTANCE AND LEVELING SYSTEMS

#### 03 Precise Leveling with LEVEL PRO ACTIVE

- > Innovative **LEVEL PRO ACTIVE** leveling system
- > Optimized multiplex system
- > Optimized 3D and laser leveling
- > Leveling boom with Sonic Ski sensor on one or both sides
- > Active cross-leveling via front lifting columns
- > **Copy Slope Sensor** – active transverse leveling via front lifting columns

#### 04 Informative WPT - WIRTGEN PERFORMANCE TRACKER

- > Field-tested WITOS FleetView telematics system with optional WPT
- > Direct display of truck loading
- > Clear site documentation
- > Quick and exact site accounting

#### 05 Intuitive Assistance Systems

- > **MILL ASSIST** automatic mode with additional pre-selection of operating strategy
- > Automatic raising of scraper blade and side plates when necessary
- > Automatic front pendulum stroke control
- > Active Conveyor
- > Active Lift Up
- > Active Transport Control

## MILLING AND LOADING

**06 Superior Cutting Technology Boosts Performance**

- > Extremely hard-wearing HT22 quick-change toolholder system with field-proven HT22 **PLUS** upper part
- > Optimized side plate control at right by two hydraulic cylinders
- > New material scraper for optimal milling without full or partial loading of material
- > Program for protection of edge rings when milling in bends
- > Quick pick changing

**07 Maximum Loading Capacity**

- > Extremely large conveyor slewing angle of 65° to the left and right
- > Two conveyor slewing speeds
- > Higher belt cleat profile for increased conveyor capacity
- > "Booster" function for temporarily increased discharge trajectory

## PERFORMANCE AND SERVICE

**08 Performance Meets Efficiency**

- > State-of-the-art John Deere engine with specially optimized torque curve for cold milling
- > Extended milling drum rotation speed range for a wide range of cost-efficient milling applications
- > Wide-opening hydraulic engine cowling for easy maintenance
- > Rugged electrics concept with CAN bus reserve circuits



## DRIVING AND STEERING

**09 Fast and Dynamic Maneuvering**

- > ISC - intelligent speed control for minimal track slip
- > Fast machine height adjustment
- > Dynamic maneuvering at travel speeds of up to 7.5 km/h
- > Easily mounted 400 kg additional weight

## ENVIRONMENT AND SUSTAINABILITY

**10 Minimal Environmental Impact for the Future**

- > Dynamic engine control assistant for low CO<sub>2</sub> emissions
- > Two-part water spray bar with performance-dependent injection for minimal water consumption
- > Fuel-saving, low-noise dual fan concept
- > Optimized, effective VCS extraction system

# EXCLUSIVE OPERATOR'S CABIN FOR HIGH PERFORMANCE

## Relaxed Work

Perfectly designed operator's cabin

## Everything under Control

Ergonomic multifunctional armrest





- 01 Ergonomics and comfort increase operator well-being and performance.
- 02 5" control screen with clearly arranged, informative displays.

### High-Quality Camera System with Two or Five Cameras

With two cameras, the standard 7" control panel displays a high-resolution view of the loading situation and the area in front of the left side plate. With five cameras, the additional 10" control panel shows the area behind the machine, the loading situation, the area in front of the left side plate, the front left crawler unit, and the left side of the machine.

### Powerful Complete LED Lighting Package

The compact milling machine has particularly powerful LED working lights all around the machine, lighting for the operator's platform, illuminated control panels, and "welcome and go home" lighting for convenient access.

### Operator's Platform with Lateral Shift Function for Optimal Vision Along the Zero Side

The operator's platform can be hydraulically moved outwards by nearly 200 mm to provide an optimal view of the milling drum unit and the front right-hand crawler unit.

### Platform Design with Perfect Ergonomics for a High Level of Operator Comfort and Well-Being

The operator's platform has been completely redesigned and stands out for its comfort, ergonomically designed controls, high-quality feel, and modern design. All in all, this significantly increases the operator's sense of well-being and thus their performance.

### The Large 5-Inch Control Screen in the Multifunctional Armrest Displays Essential Information

In addition to the milling depth on the right and left, a wealth of important information such as machine load conditions, temperatures, hydraulic pressures, diesel and water fill levels, and status and diagnostic messages are clearly displayed in color on the 5" control screen in the armrest.

### Ergonomic Access with Automatic Height Adaptation

The ergonomically designed access ladder at the rear of the machine features automatic height control for effortless access to the operator's platform in any working situation with sufficient ground clearance.

### External Control Panel with Frequently Used Machine Functions

Thanks to the additional external control panel, ground crews can effortlessly perform practical operating functions such as engine start/stop, water test, scraper up/down, or machine height adjustment.

### Ample Storage Space

The compact milling machine offers plenty of storage space for leveling sensors, pick ejectors, and pick boxes. The storage compartments offer space for up to nine pick boxes in total.

### Smart Vandalism Protection Concept for Control Units

The innovative vandalism protection system allows the linear 7" universal display and the 10" camera display (optional) to be moved vertically and thus reliably secured against theft and destruction. The main control panel can be easily folded in and locked.

# INNOVATIVE COMFORT CABIN FOR EVEN HIGHER PRODUCTIVITY

## Climb in and Enjoy the Comfort

Full weatherproofing and dust protection meets perfect ergonomics

## Ideal Conditions for a Productive Working Day

Perfect air conditioning and temperature control

01





### High Motivation Factor

The cabin is an attractive workplace and stands out as a unique highlight in the compact milling machine class. It motivates operators and further increases their commitment to delivering an excellent job.

### Outstanding Low-Fatigue Operating Comfort

In addition to providing optimal protection against noise, dust, and weather conditions such as rain, wind, heat, and cold, the cabin also offers maximum operating comfort: the state-of-the-art workplace offers air conditioning with temperature regulation, low ambient noise levels, a radio, a low-fatigue operating concept, and more, as well as continuous operator productivity.

### Clean and Fresh Air in the Cabin

The air flowing into the positive-pressure cabin is cleaned by an efficient filter system to prevent dust and dirt particles entering from outside. This guarantees minimization of the dust to which operators are typically exposed on construction sites.

### More Effective Protection Against Vandalism

The lockable cabin door reliably protects against forcible entry, willful damage to control panels and the interior, and theft. Extra vandalism protection equipment no longer needs to be installed or removed and stowed away.

02



**01** The operator is always ideally protected against external influences when at work in the cabin.

**02** The cabin offers highest levels of operating comfort and ergonomics.

# INNOVATIVE COMFORT CABIN FOR EVEN HIGHER PRODUCTIVITY

## All-Round Vision

Large glazed surfaces guarantee ideal all-round vision

## Optimal Adaptation to Site Conditions

Hydraulically adjustable cabin

01



### High-Quality Camera System with Five Cameras

The additional, high-resolution 10" control panel shows the area behind the machine, the loading situation, the area in front of the left side plate, the front left track unit, and the left side of the machine. Thanks to the large windows, the machine operator always has an ideal overview of the entire working environment.

### Improved Communication

The low-noise cabin enables easier communication with the site office or crew members during jobs.

### Milling Also Possible in the Case of Obstacle Heights of 3.0 Meters or More

The compact milling machine with a hydraulically adjustable cabin can also cope with working situations where milling has to be carried out under obstacles with an obstacle height of 3.0 meters or more. This is not possible in the case of machines with the weather canopy folded away.

### Easy Transportation

Thanks to the low transport configuration of the cabin, the height of the machine remains unchanged. This means that no limitations apply when transporting the machine.

**01** In combination with its all-round glazing, the state-of-the-art workplace offers an ideal all-round view of the construction site.

**02** Easy access to the cabin at the rear of the machine.

**03** Different working positions on the compact milling machine.

02



03

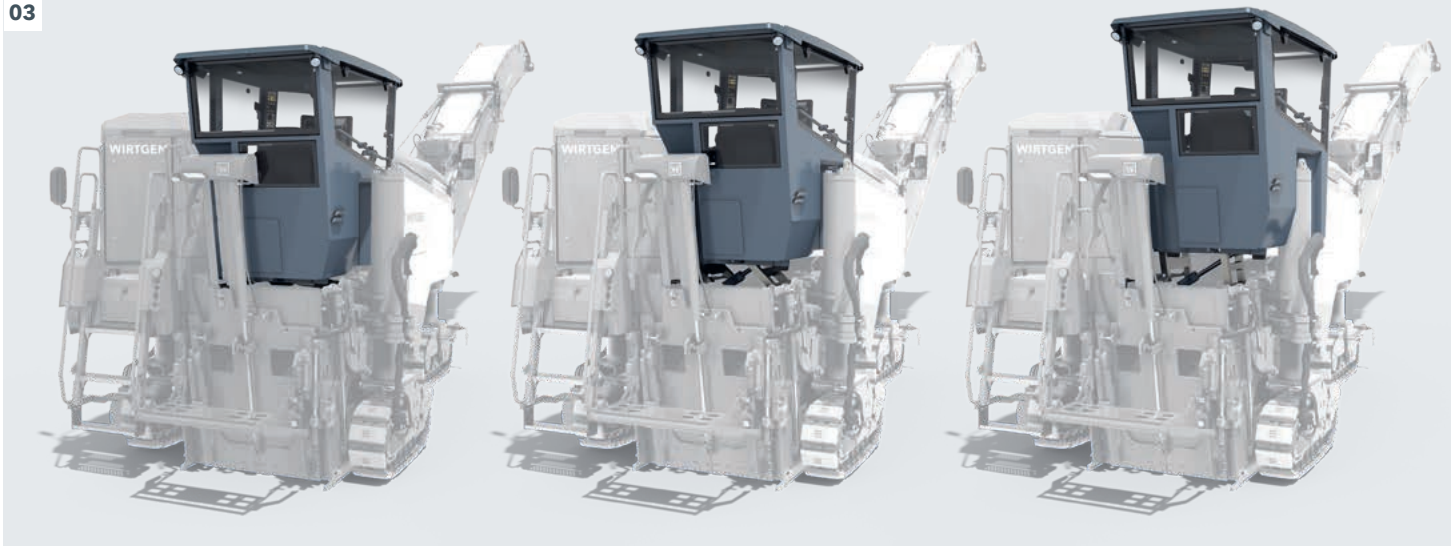

# PRECISE LEVELING WITH LEVEL PRO ACTIVE



**Always Makes the Grade**  
LEVEL PRO ACTIVE

**Perfect Leveling**  
Multiplex system

### Innovative LEVEL PRO ACTIVE Leveling System

The high-precision **LEVEL PRO ACTIVE** leveling system specially developed for cold milling machines features an informative 7" control panel that is not only intuitive and easy to operate, but also offers many automatic and additional functions to make the operator's job easier. For example, the entire machine can be raised automatically to drive over a manhole cover and then lowered back to the starting position.

### Optimized Multiplex System

The user-friendly multiplex system is easy to mount to the machine. It consists of a two additional ultrasonic sensors per machine side mounted on flexibly adjustable brackets. Benefits of the system include its low weight and wide adjustment range for a variety of leveling applications.

### Optimized 3D and Laser Leveling

The drastically simplified method of installing the pole-mounted laser sensor makes it easier to use 3D systems.

### Leveling Boom with Sonic Ski Sensor on One or Both Sides

The leveling booms with Sonic-Ski sensor make the contactless scanning of a line or a reference surface next to the milled edge on both sides possible. In this context, the boom with the Sonic-Ski sensor can be hydraulically shifted outward by up to 840 mm from the operator's platform in milling mode. A mechanical adjustment offers an additional 880 mm of telescopic travel.

### Active Cross-Leveling via Front Lifting Columns

Displacement sensors in the two front lifting columns determine the difference in height between the two crawler units at the front and then always automatically align the machine parallel to the ground surface. Depending on the application, cross-leveling can be used instead of side plate leveling, for example.

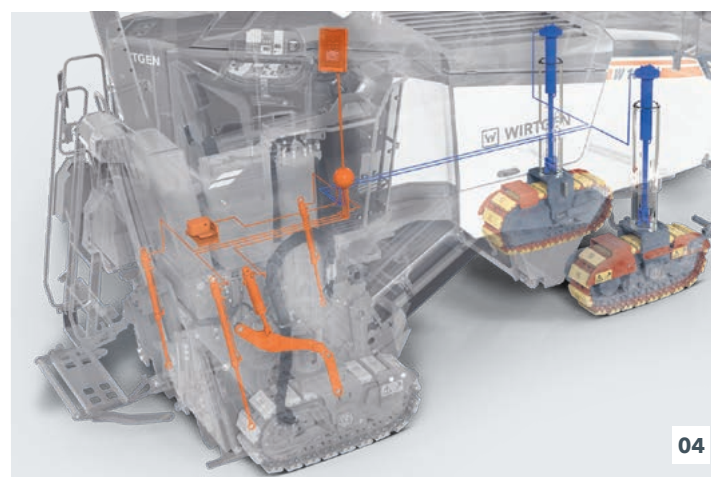
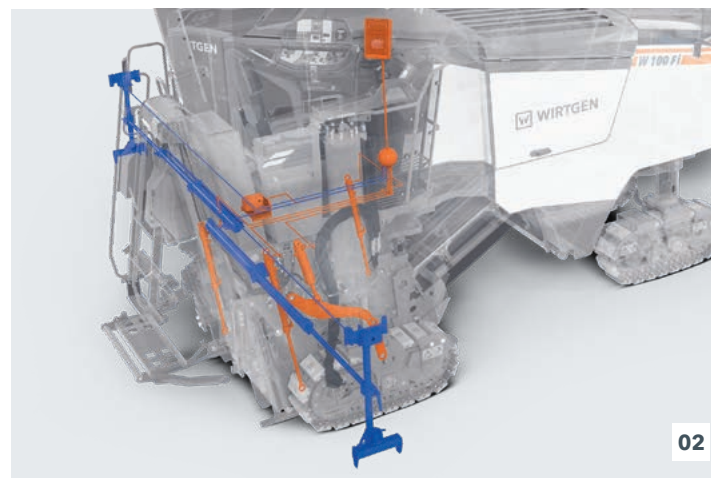
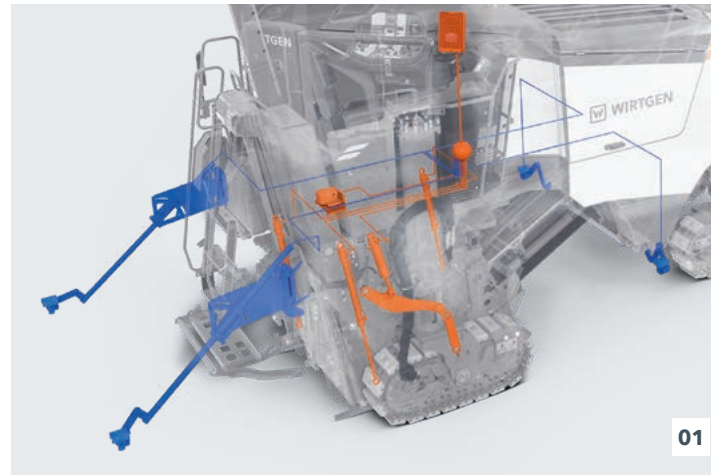

- 01** Multiplex system with up to four additional ultrasonic sensors
- 02** Telescoping leveling boom on the right or left
- 03** 3D leveling / laser leveling
- 04** Detection of the difference in height between the front lifting columns

-----

■ = Standard equipment  
■ = Optional equipment

# WIRTGEN PERFORMANCE TRACKER

Informative WPT

## Comprehensive Job Data

Site reports via email

## Simple Accounting

No extra costs for surveying

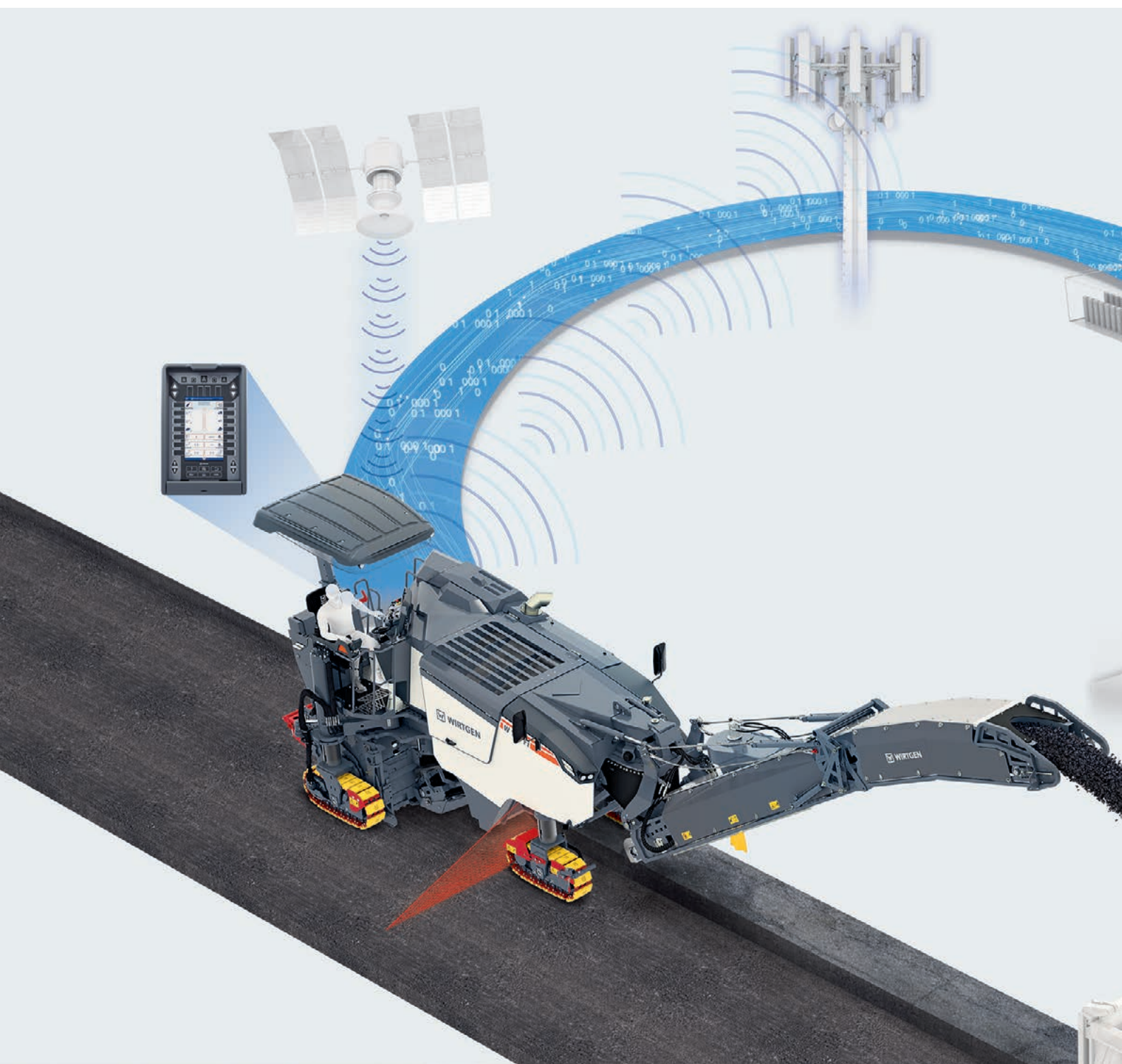

**01** The operator is always aware of the current machine and application parameters - at the end of the workday, the data is transmitted to the machine owner.

**02** The actual, currently active milling width is scanned by a laser scanner and clearly displayed on the control panel.

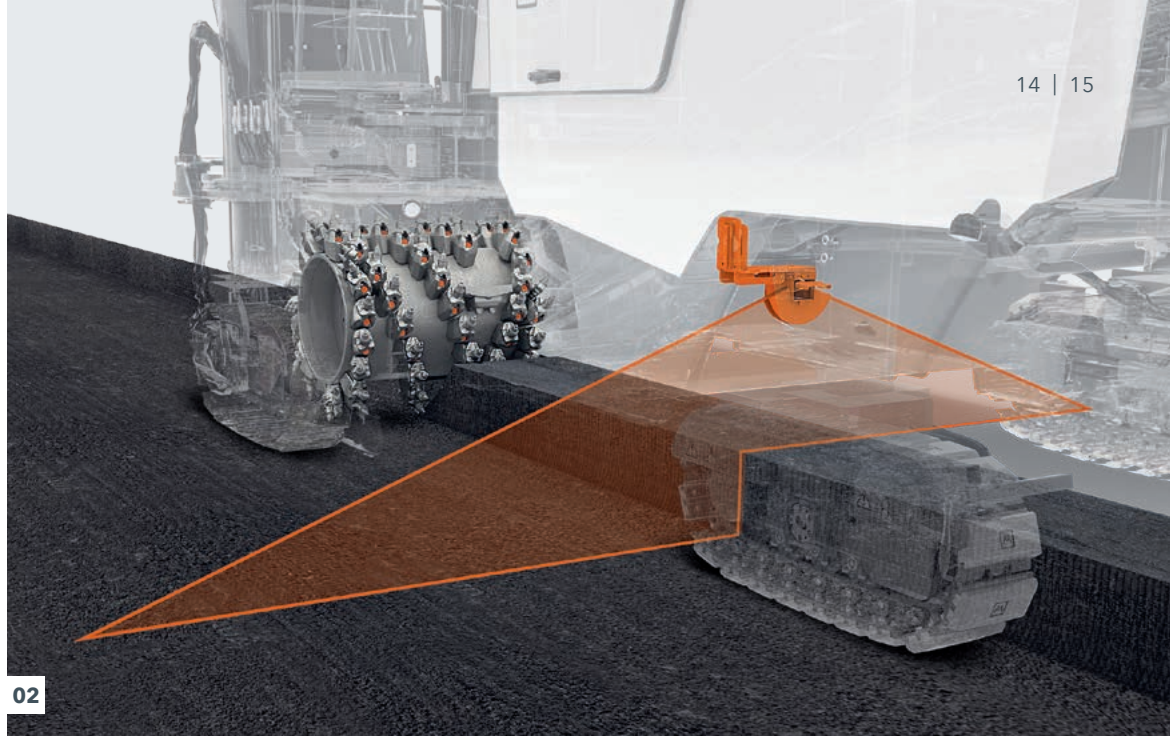

02



01

### **Field-Tested WITOS FleetView Telematics System with Optional WPT**

The WITOS FleetView telematics system consists of the control unit (TCU) with a GPS receiver and a license to use the WITOS FleetView web application. The web interface provides a compact overview of the machine status with consumption data, operating hours, position data, error messages, and service intervals. The additional WPT equipment also tracks the machine's actual milling performance and truck loads and provides consumption and position data in a clear, automatically generated job site report.

#### **Direct Display of Truck Loading**

The actual, currently active milling width is scanned by a laser scanner and displayed directly on the control panel together with the current truck load. The panel also displays the tonnage currently loaded onto the truck, making it easy to avoid overloading.

#### **Clear Site Documentation**

After completing a milling job, a site survey report is automatically generated in both Excel and PDF formats and sent by email to the machine owner's job management office, for example. The site survey report contains precise information on the milling volume, milled area, milling depth with the corresponding GPS position, and consumption data.

#### **Quick and Exact Site Accounting**

The prompt, simple calculation of the surface area required for the correct invoicing of the work performed saves further costs, e.g. by an external surveyor.

# INNOVATIVE MILL ASSIST

## Efficient Machine Control

### MILL ASSIST Automatic Mode with Additional Pre-Selection of Operating Strategy

In automatic mode, the innovative **MILL ASSIST** machine control system always selects the operating strategy with the best balance between performance and costs. In doing so, the process optimization automatically adjusts the speed of the diesel engine and milling drum, the travel drive, the water system, and the machine's advance speed. This significantly reduces the operator's workload while improving machine performance and considerably reducing diesel consumption, CO<sub>2</sub> emissions, and noise.

The operator can also pre-select one of three working strategies: "ECO," "performance-optimized," or "milling pattern quality." The machine then automatically adjusts the main parameters based on the selected operating strategy and displays suggested optimizations, if necessary. The operator can preset the required milling pattern quality by pre-selecting from a scale ranging from 1 to 10. This then automatically sets the milling drum rotation speed and the milling speed, taking the milling drum type into account.

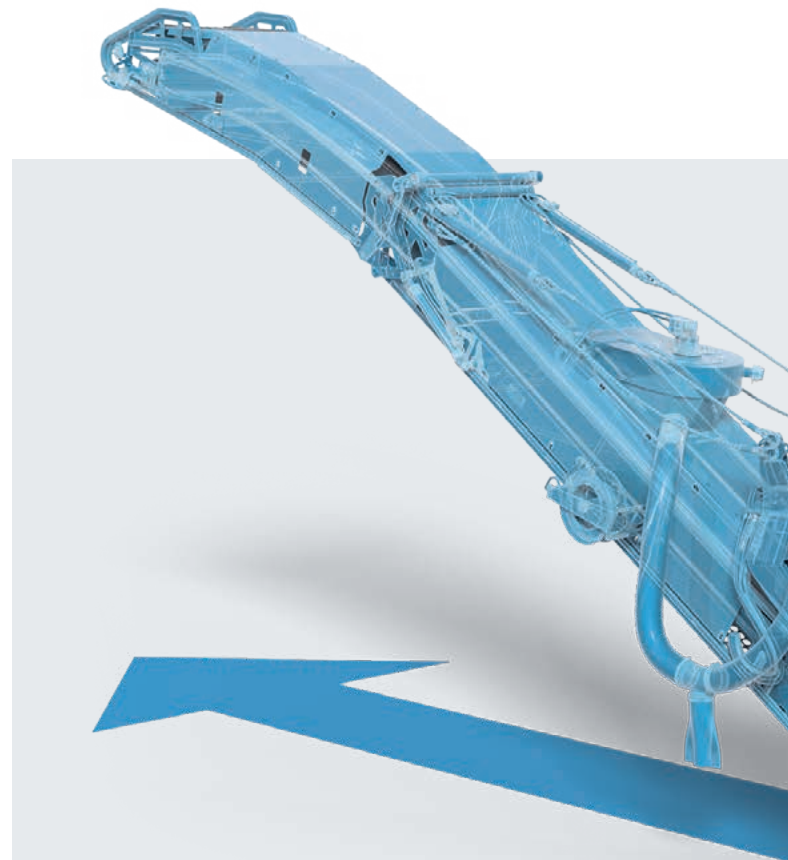
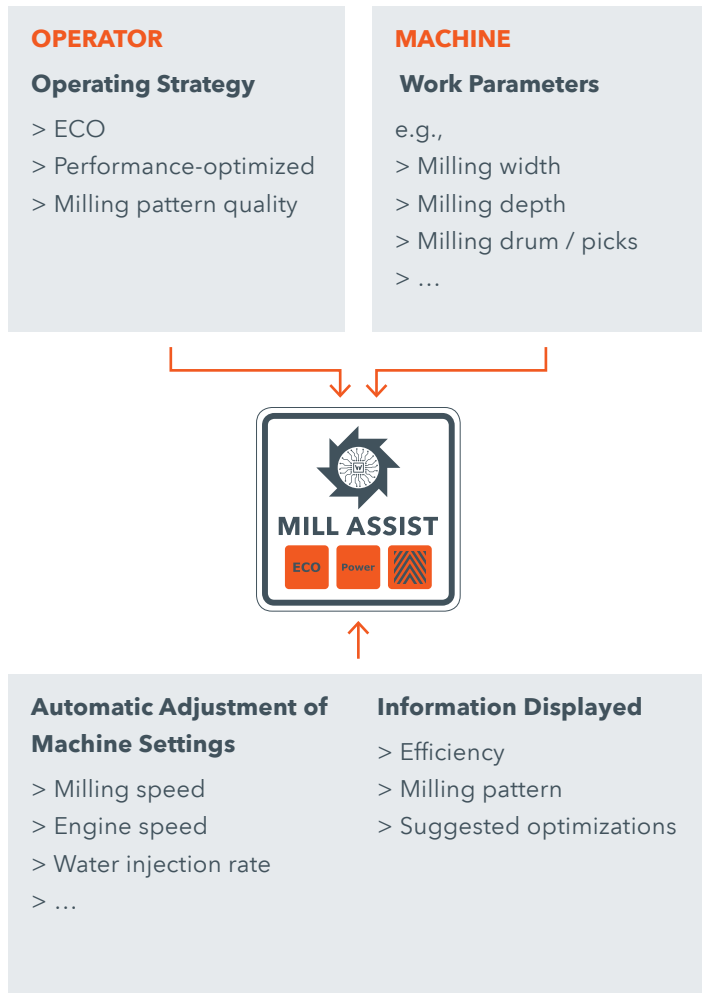



### **Automatic Raising of Scraper Blade and Side Plates when Necessary**

If necessary, the right and left side plates are briefly raised automatically to prevent them from sinking into soft ground. Overload sensors protect the milling drum unit from damage by triggering the scraper to lift briefly, such as to avoid obstacles or uneven ground.

### **Automatic Front Pendulum Stroke Control**

The automatic height adjustment of the two front lifting columns controls the pendulum stroke so that the crawler units always maintain sufficient ground contact and traction, even on uneven terrain.

### **Active Conveyor**

When repositioning the discharge conveyor in difficult job site situations, the semi-automatic Active Conveyor swing

angle control system assists the operator in the best possible way – such as when milling in intersections or bypassing road installations.

### **Active Lift Up**

This automatic function avoids unevenness in the milling surface when the machine is idle by raising the milling drum.

### **Active Transport Control**

This automatic function conveniently aligns the cold milling machine horizontally when moving it at traveling speed. In addition, it automatically switches off the water supply and conveyor operation.

## **MILL ASSIST**

Automatic efficient milling

## **Three Predefined Strategies**

Optimal machine adjustment

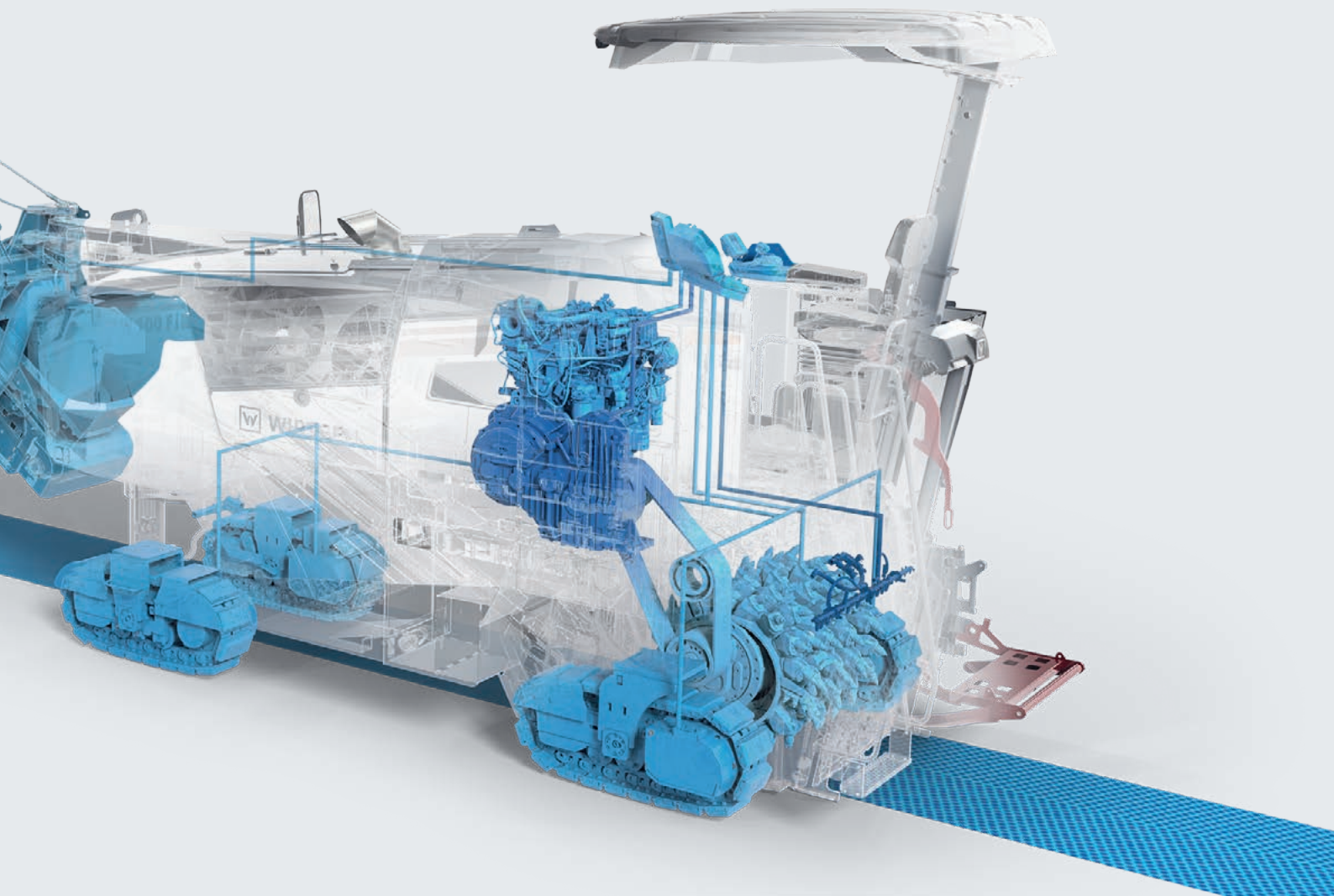

# SUPERIOR CUTTING TECHNOLOGY

## Extremely Hard-Wearing HT22 Quick-Change Toolholder System with Field-Proven HT22 PLUS Upper Part

The milling drums of the compact milling machine are equipped with the HT22 quick-change toolholder system, making them perfect for highly demanding milling tasks. In addition, the heavy-duty milling drum design enables the upper parts of the quick-change toolholders to be changed quickly on site, if required.

The new HT22 PLUS quick-change toolholder upper part features innovative centering marks on the tool contact surface. In combination with the new X<sup>2</sup> generation of round-shank picks, this reduces toolholder wear by up to 25%. In addition, the rotation behavior of the round shaft pick has been optimized. The new upper part offers considerable benefits such as higher milled surface quality and longer intervals between changes.

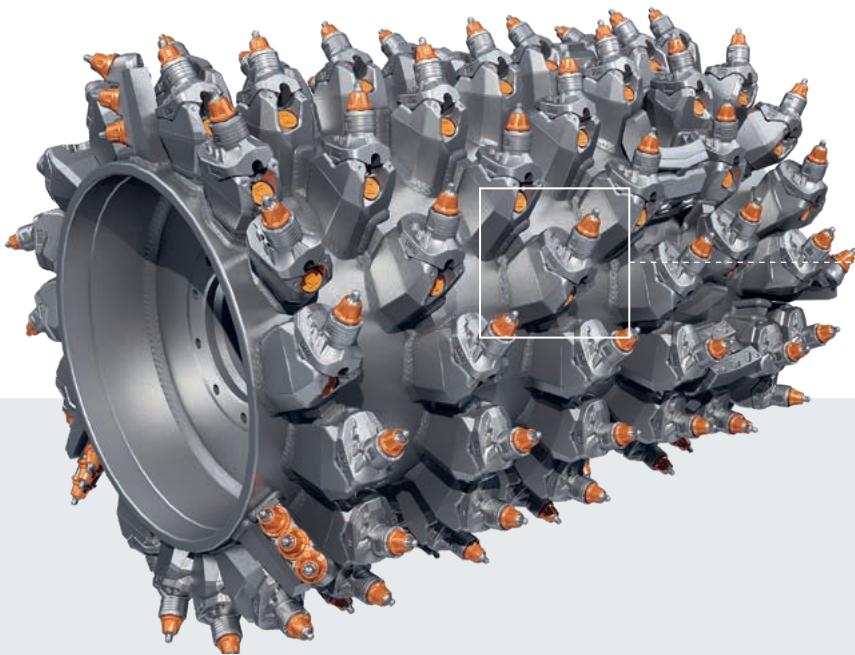



**W 100 Fi**  
with 1.0 m milling drum unit



**Standard Milling Drum**  
Milling width: 1,000 mm  
Milling depth: 0 - 330 mm  
Tool spacing: 15 mm

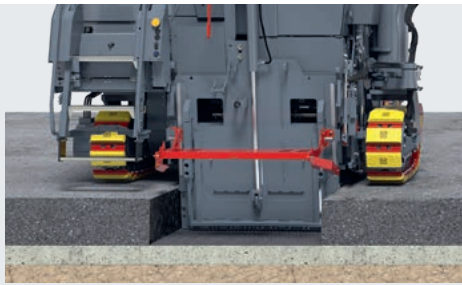

**W 120 Fi**  
with 1.2-m milling drum unit



**Standard Milling Drum**  
Milling width: 1,200 mm  
Milling depth: 0 - 330 mm  
Tool spacing: 15 mm

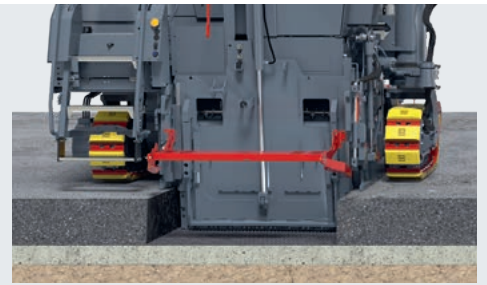

**W 130 Fi**  
with 1.3-m milling drum unit



**Standard Milling Drum**  
Milling width: 1,300 mm  
Milling depth: 0 - 330 mm  
Tool spacing: 15 mm

02

### Optimized Side Plate Control at Right by Two Hydraulic Cylinders

Two hydraulic cylinders are responsible for robust side plate guidance without jamming, ensuring precise leveling. The contact pressure is set from the operator's platform.

### New Material Scraper for Optimal Milling without Full or Partial Loading of Material

The flexible material scraper at the rear replaces the usual safety bar and ensures that the deposited material features a uniform profile when milling without loading or partial loading. In addition, the folding design of the material scraper allows the machine to be reversed close and accurately to obstacles.

- 01 Extremely wear-resistant HT22 quick-change toolholder system.
- 02 1.0 m, 1.2 m, and 1.3 m milling drum units.
- 03 Flexible material scraper at the rear of the machine.
- 04 Two hydraulic cylinders on the right side plate.



### Program for Protection of Edge Rings when Milling in Bends

The automatic function increases the milling drum speed when milling in bends, thus reducing material wear on the edge ring segments that are subjected to higher stress in curves.

### Quick Pick Changing

The hydraulically operated milling drum rotation device and pick ejector make it easier to change picks - even when the engine is switched off.

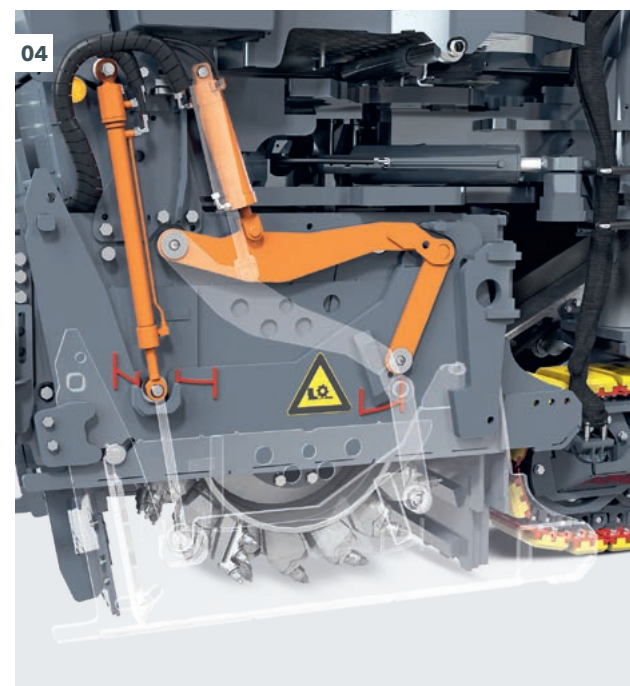

# MAXIMUM LOADING CAPACITY

## Unparalleled Precision

Two swing speeds

## Quickly Clear Away the Milled Material

New "booster" function

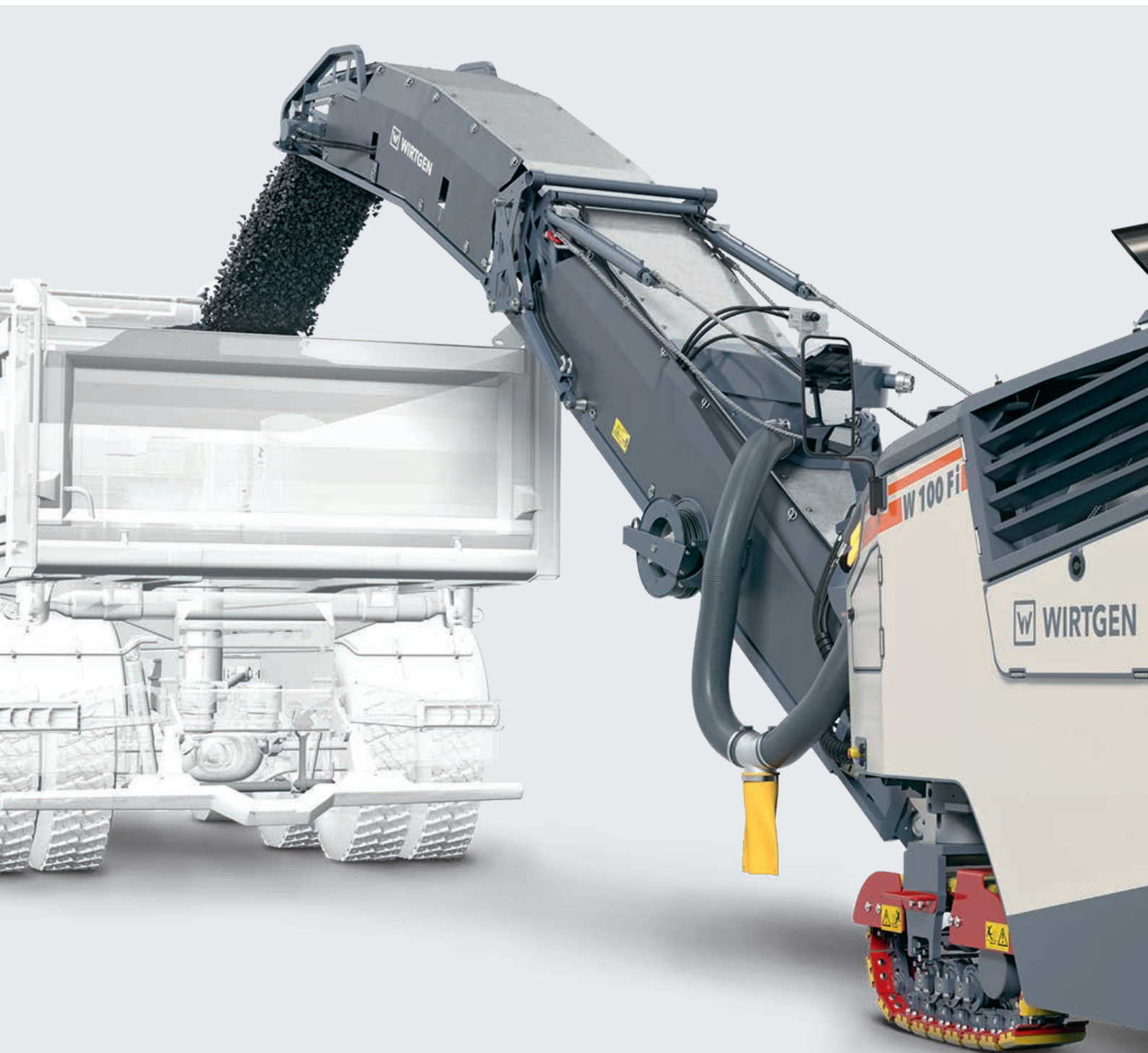

**01** High-performance loading of the milled material.

**02** Discharge conveyor with extremely large slewing range.



**02**

**01**



### **Extremely Large Conveyor Swing Angle of 65° to the Right and Left**

Wide conveyor swing angles of 65° to both sides make it possible to load material even in difficult situations, e.g., in intersections or turning areas.

### **Two Conveyor Swing Speeds**

The discharge conveyor can swing slowly to ensure that the material is loaded precisely, while swinging at high speed ensures that the discharge conveyor is positioned quickly.

### **Higher Belt Cleat Profile for Increased Conveyor Capacity**

The large belt width and the belt cleat profile increased by 100% increase the loading capacity and thus the efficiency of the entire milling process.

### **"Booster" Function for Temporarily Increased Discharge Trajectory**

Pressing the "Booster" button on the main control panel briefly increases the belt speed and conveying capacity of the discharge conveyor by 20% in order to temporarily transport the milled material particularly high or far onto a truck bed.

# PERFORMANCE MEETS EFFICIENCY

Powerful John Deere Engine Technology

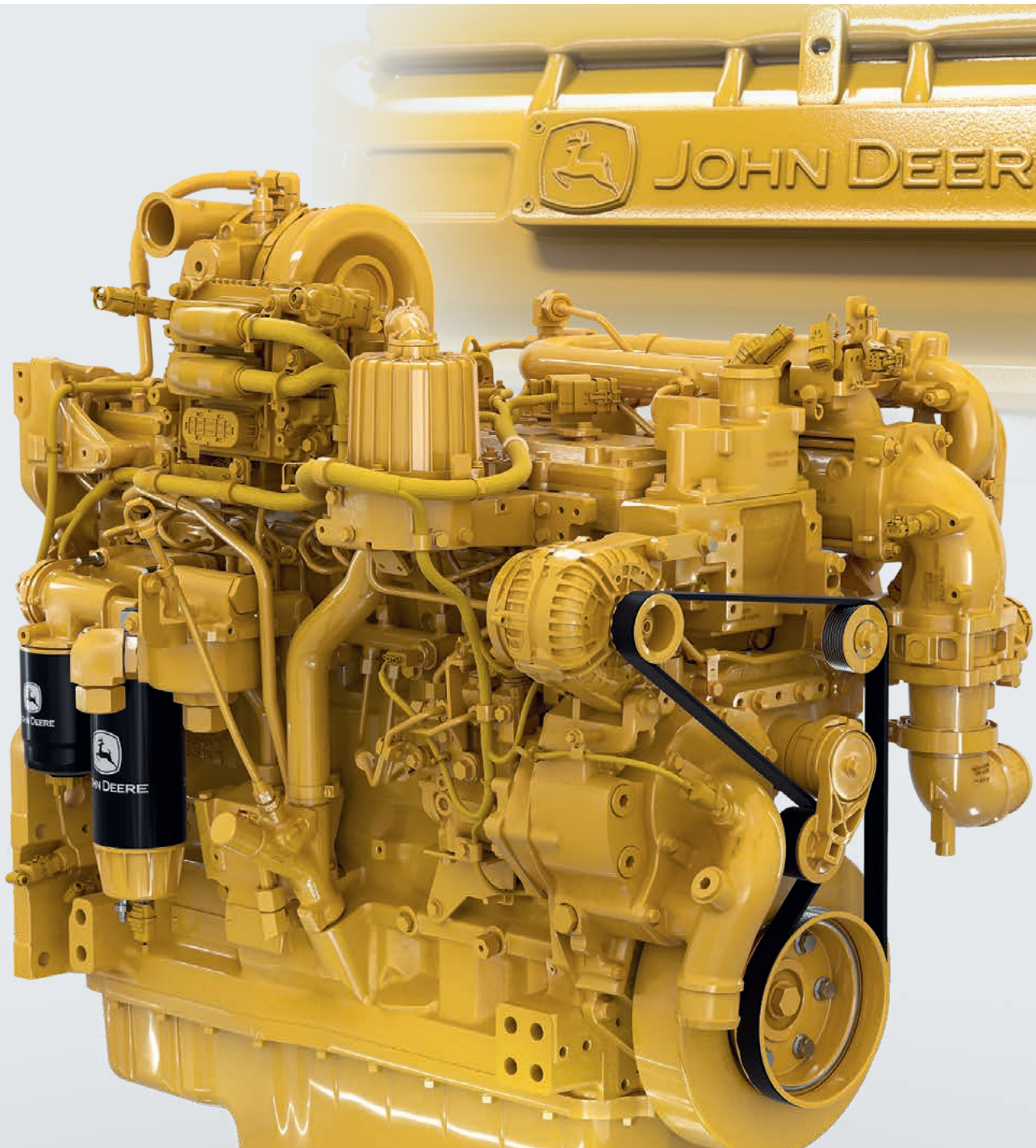

**From a Single Source**  
John Deere brand engine technology

**Perfect for Cold Milling Machines**  
Engine characteristics tailored to the application

**01** When equipped with the MILL ASSIST milling application control system, the compact milling machine offers an extremely wide milling drum speed range to dramatically reduce diesel consumption, carbon emissions, and pick wear.

### W 100 Fi, W 120 Fi, and W 130 Fi Cold Milling Machine Engine Characteristics

01

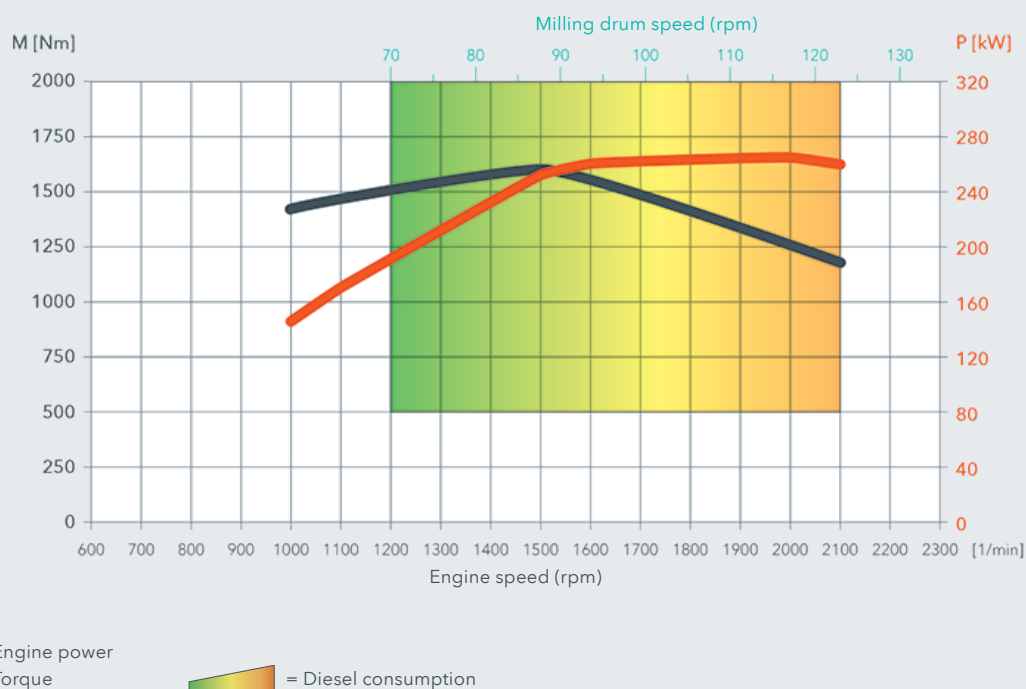

#### State-Of-The-Art John Deere Engine with Specially Optimized Torque Curve for Cold Milling

The economical John Deere diesel engine meets the strict requirements of EU Stage 5 / US EPA Tier 4f emissions standards and offers an impressive engine output of 265 kW / 360 PS with high maximum torque. It is worth noting that WIRTGEN and John Deere worked closely together to adapt the torque characteristics of the engine to make it ideal for cold milling machines. All in all, this translates into reduced fuel consumption and fast, productive operations, even at maximum milling depth.

#### Extended Milling Drum Speed Range for a Wide Range of Cost-Efficient Milling Applications

Thanks to the intelligent engine control unit in conjunction with **MILL ASSIST**, the compact milling machine offers an extremely wide usable milling drum speed range. The new lower engine speed range is particularly effective in achieving significant diesel savings and tremendous milling performance in numerous applications.

#### Wide-Opening Hydraulic Engine Cowling for Easy Maintenance

The engine cover can be hydraulically opened wide by almost 90° at the push of a button, providing easy access to the maintenance components in the engine compartment.

#### Rugged Electrics Concept with Can Bus Reserve Circuits

If necessary, the CAN bus can be variably reconnected via backup lines. The main control elements are equipped with two-channel signal transmission, meaning that they can still be used if one signal fails. Information about a signal failure is also displayed to the operator.

# FAST AND DYNAMIC MANEUVERING

## ISC - Intelligent Speed Control for Minimal Track Slip

The intelligent ISC (Intelligent Speed Control) system delivers optimum, even traction – electronic traction control prevents individual crawler units from slipping as far as possible, even under difficult conditions. In addition, ISC keeps the machine's advance rate in the ideal engine utilization range and electronically matches the curve speed of the inner and outer crawler units to each other. This minimizes track pad wear.

## Fast Machine Height Adjustment

The new machine height adjustment system not only functions with extreme precision for high-quality milling results, but also enables fast stroke movements for rapid positioning and lifting.

## Dynamic Maneuvering at Travel Speeds of up To 7.5 km/h

The machine's maximum speed of 7.5 km/h ensures that jobs are completed particularly quickly.



**Always Powerful**  
Intelligent travel drive

**High Travel Speed**  
On to the next job quickly



- 01 The compact milling machine stands out due to its minimal milling radii.
- 02 The rear crawler unit on the right side has three fixed positions. In the "extended" position, the entire rear right-hand crawler unit is positioned within the cutting circle of the previous working pass. This makes it easy to begin milling the next working pass with zero offset.

**Easily Mounted 400 kg Additional Weight**

The low net weight of the compact milling machine in combination with the easily mountable 400 kg additional weight at the rear of the machine makes a high operating weight, ideal traction, and smooth and easy transport possible, depending on the requirements.



01

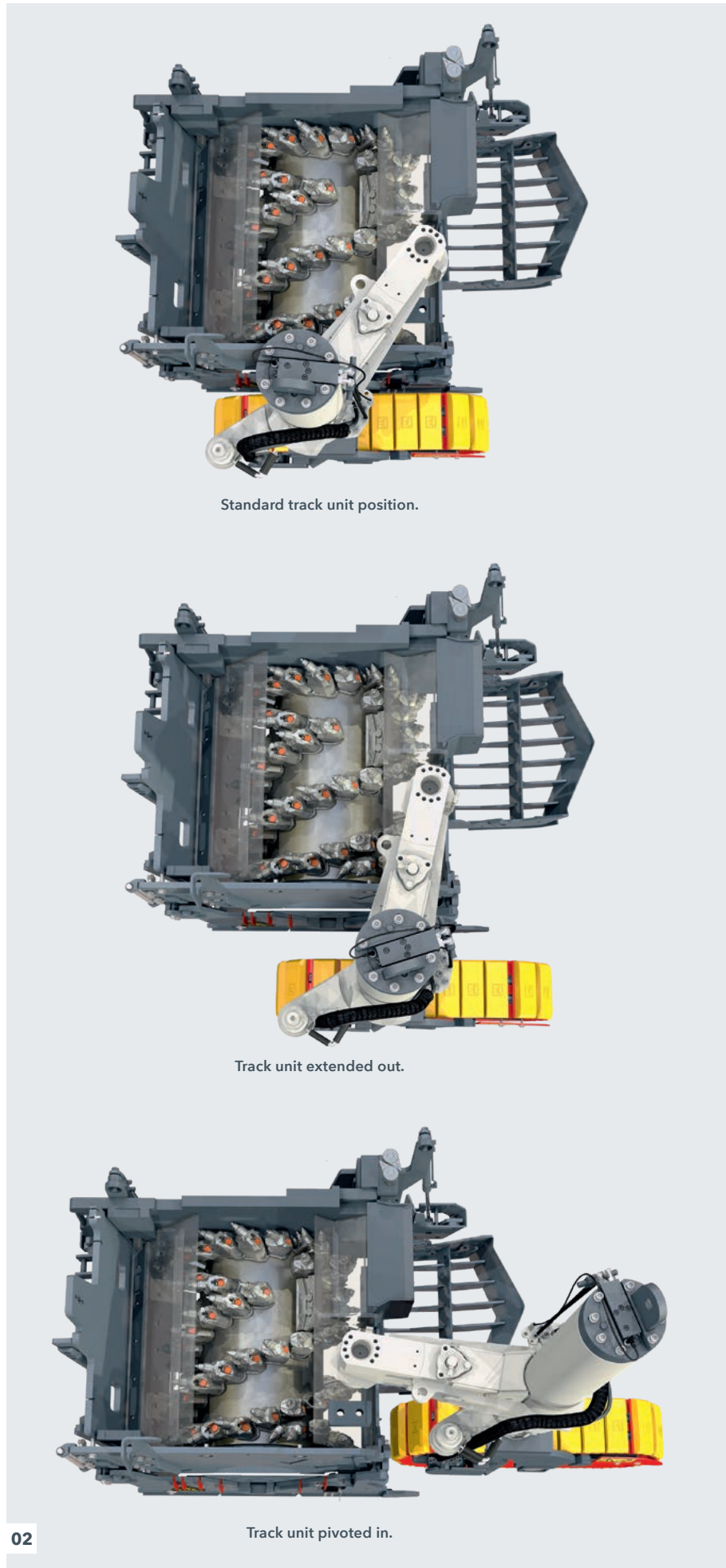

Standard track unit position.

Track unit extended out.

Track unit pivoted in.

02

# MINIMAL ENVIRONMENTAL IMPACT FOR THE FUTURE

## **Dynamic Engine Control Assistant for Low CO<sub>2</sub> Emissions**

In combination with MILL ASSIST, the efficient John Deere engine, and the wide milling drum speed range, the intelligent engine control system minimizes CO<sub>2</sub> emissions.

## **Two-Part Water Spray Bar with Performance-Dependent Injection for Minimal Water Consumption**

Two separate water spray bar segments that can be activated electrically from the operator's platform allow the optimum amount of water to be added to the milling process, such as when milling only half the width of a lane. Automatically switching the water system on and off as well as reducing the amount of water used depending on the milling speed not only cuts water consumption by up to 20%, but also reduces machine downtimes during operation.

## **Fuel-Saving, Low-Noise Dual Fan Concept**

Two speed-controlled and intelligently positioned fans cool the diesel engine and hydraulic system as required. As a result, the cooling system also helps efficiently reduce diesel consumption and noise.

## **Efficiency-Optimized VCS Extraction System**

The well-sealed VCS exhaust system improves air quality and visibility in the machine operator's and ground crew's working area. In addition, the easily accessible VCS suction channel makes cleaning the system easier.

### **Focus on the Environment**

Lower CO<sub>2</sub> emissions

### **Fuel Saver**

Intelligently controlled



The front loader in the one-meter class is characterized by its outstanding performance and flexibility at working widths of 1.0 m, 1.2 m, or 1.3 m. Compact dimensions and optimized machine weight make it ideal for a wide range of applications - including on job sites with limited space, such as in urban areas. Switching FCS milling drums with different tool spacings and different working widths allows the milling machine to be used for a wide range of additional applications.



TECHNICAL SPECIFICATIONS	W 100 Fi	W 120 Fi	W 130 Fi
<b>Milling Drum</b>			
Milling width	1,000 mm	1,200 mm	1,300 mm
Milling depth <sup>1)</sup>	0 - 330 mm		
Cutting diameter	980 mm		
<b>Engine</b>			
Manufacturer	John Deere		
Type	6090HD-S5-PVR		
Cooling	Water		
Number of cylinders	6		
Rated power at 2,100 rpm	260 kW / 349 hp / 354 PS		
Maximum power at 1,900 - 2,000 rpm	265 kW / 355 hp / 360 PS		
Displacement	9.0 l		
Fuel consumption at rated power   during a mixture of job site operations	62.7 l/h   25.1 l/h		
Sound power level in accordance with DIN EN 500-2 engine   operator's platform	≤ 107 dB(A)   ≥ 90 dB(A)		
Emissions standard	EU Stage 5 / US EPA Tier 4f		
<b>Electrical System</b>			
Power supply	24 V		
<b>Tank Capacities</b>			
Fuel	610 l		
AdBlue® / DEF <sup>2)</sup>	44 l		
Hydraulic oil	115 l		
Water	1,400 l	1,600 l	1,600 l
<b>Driving Performance</b>			
Max. milling speed	0 - 60 m/min (0 - 3.6 km/h)		
Max. speed on wheels	0 - 125 m/min (0 - 7.5 km/h)		
Max. speed on tracks	0 - 125 m/min (0 - 7.5 km/h)		
<b>Track Units</b>			
Tire size, front / rear (D x W)	660 x 280 mm		
Track chains front / back (L x W x H)	1,360 x 260 x 584 mm		
<b>Loading of Milled Material</b>			
Belt width of primary conveyor	650 mm		
Belt width of discharge conveyor	600 mm		
Theoretical capacity of discharge conveyor	176 m <sup>3</sup> /h		

TECHNICAL SPECIFICATIONS	W 100 Fi	W 120 Fi	W 130 Fi
<b>Weight of Basic Machine</b>			
Empty weight of machine without fluids	18,900 kg	19,800 kg	20,200 kg
Operating weight, CE <sup>3)</sup>	20,000 kg	21,000 kg	21,400 kg
Maximum operating weight (full tanks, full range of equipment)	22,750 kg	24,000 kg	24,500 kg
<b>Weight of Tank Contents</b>			
Water	1,400 kg	1,600 kg	1,600 kg
Fuel (0.83 kg/l)		506 kg	
AdBlue® / DEF <sup>2)</sup> (1.1 kg/l)		48 kg	
<b>Additional Weight</b>			
<b>Operator and Tools</b>			
> Machine operator		75 kg	
> 5 pick containers		125 kg	
> Tools		30 kg	
<b>Optional Milling Drum Units Instead of Standard</b>			
> Milling drum housing FB1000 FCS	280 kg	-	-
> Milling drum housing FB1200 FCS	-	330 kg	-
> Milling drum housing FB1300 FCS	-	-	370 kg
<b>Optional Milling Drums Instead of Standard</b>			
> FCS milling drum FB1000 <b>HT22 PLUS</b> LA15 with 95 picks	-80 kg	-	-
> FCS milling drum FB1200 <b>HT22 PLUS</b> LA15 with 109 picks	-	-80 kg	-
> FCS milling drum FB1300 <b>HT22 PLUS</b> LA15 with 115 picks	-	-	-80 kg
> Milling drum FB1000 <b>HT22 PLUS</b> LA18 with 88 picks	-60 kg	-	-
> Milling drum FB1200 <b>HT22 PLUS</b> LA18 with 100 picks	-	-70 kg	-
> Milling drum FB1300 <b>HT22 PLUS</b> LA18 with 105 picks	-	-	-75 kg
<b>Optional Additional Equipment</b>			
> 4 motorized wheeled chassis instead of crawler units		-1,400 kg	
> Hydraulically lowering weather canopy instead of standard		255 kg	
> Operator's platform with air-conditioned comfort cabin instead of standard		425 kg	
> Shortened discharge conveyor, 6,500 mm long, 600 mm wide, with hydraulic folding device		-45 kg	
> VCS extraction system		75 kg	
> Additional weights		470 kg	
> Foldable signal lights		40 kg	
> Leveling boom including sensor for <b>LEVEL PRO ACTIVE</b> leveling system		48 kg	
> Upgrade of <b>LEVEL PRO ACTIVE</b> with two leveling booms and one Sonic-Ski sensor		77 kg	
> Powerful high-pressure water cleaner, 150 bar, 15 l/min		42 kg	
> Air compressor system		45 kg	

<sup>1)</sup> The maximum milling depth may deviate from the value indicated due to tolerances and wear.

<sup>2)</sup> AdBlue® is a registered trademark of the German Association of the Automotive Industry (VDA)

<sup>3)</sup> Machine weight, half-full tanks, vehicle tool kits, machine operator, excluding optional equipment

SIDE VIEW / TOP VIEW W 100 Fi, W 120 Fi, W 130 Fi WITH CRAWLER UNITS

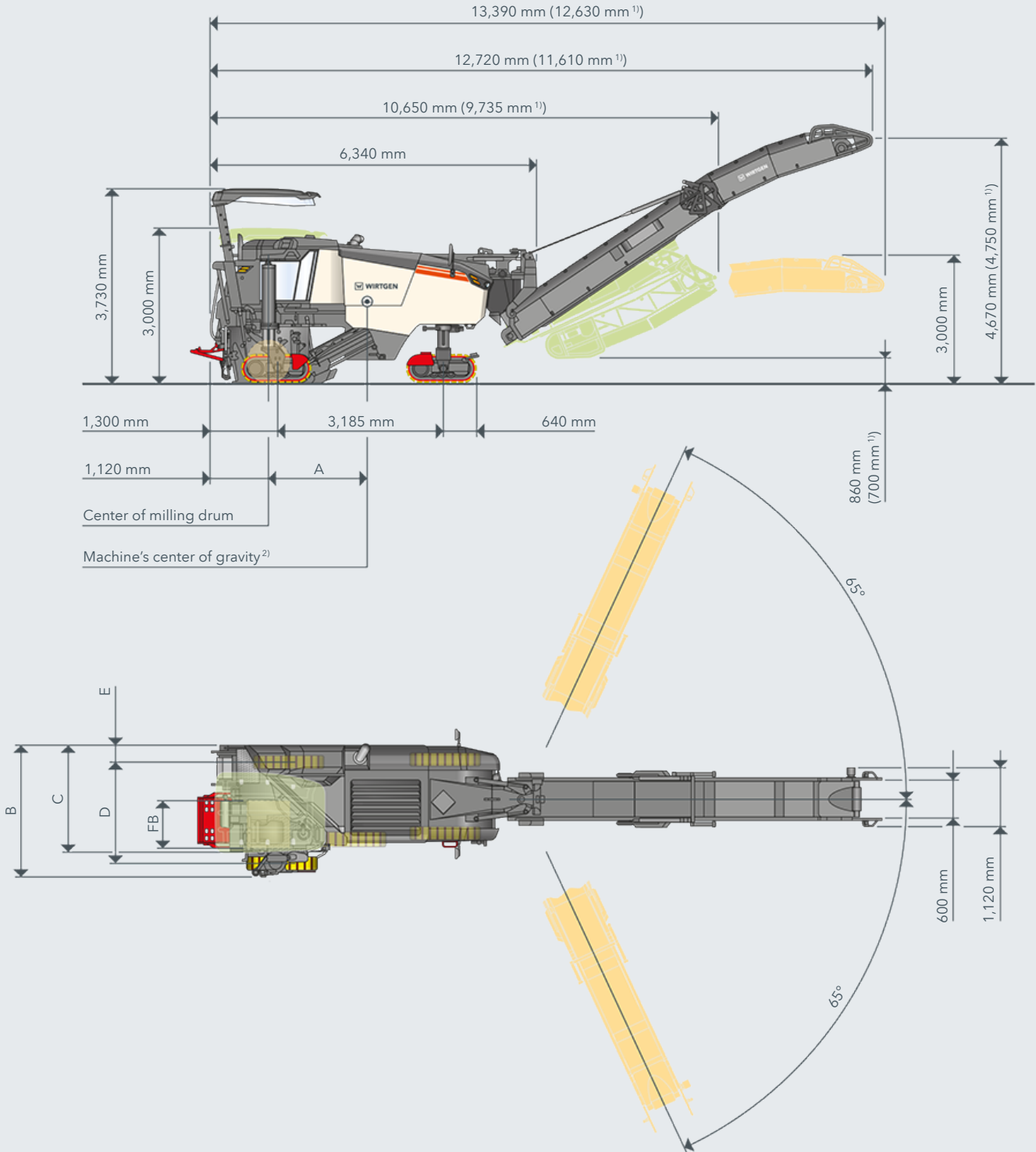

	FB	A	B	C	D	E
<b>W 100 Fi</b>	1,000 mm	1,600 mm	2,540 mm	2,120 mm	1,945 mm	335 mm
<b>W 120 Fi</b>	1,200 mm	1,620 mm	2,660 mm	2,230 mm	2,095 mm	295 mm
<b>W 130 Fi</b>	1,300 mm	1,600 mm	2,760 mm	2,330 mm	2,210 mm	295 mm

<sup>1)</sup> Folding discharge conveyor, short

<sup>2)</sup> Based on operating weight, CE with conveyor folded out

SIDE VIEW / TOP VIEW W 100 Fi, W 120 Fi, W 130 Fi WITH WHEELED CHASSIS

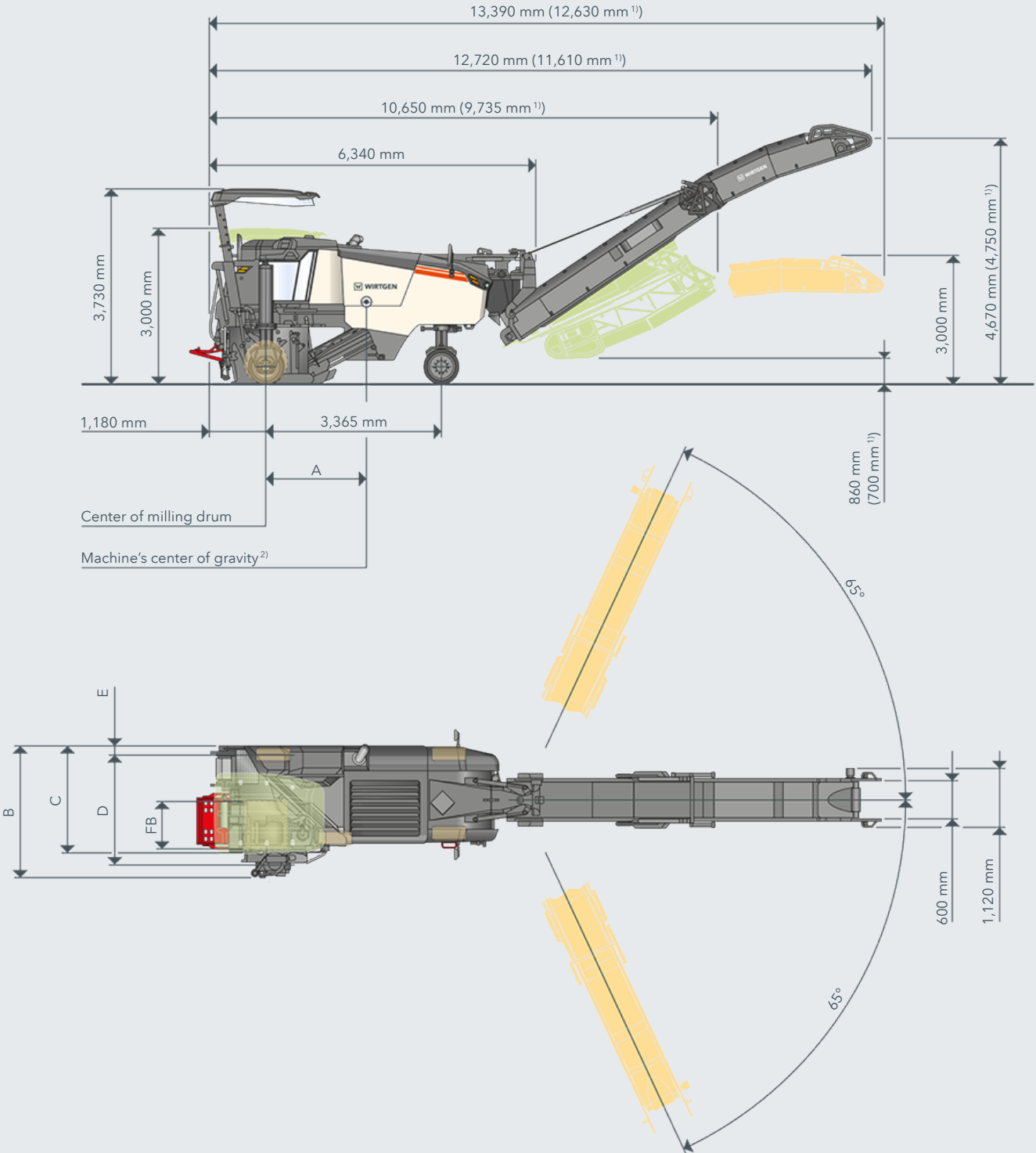

	FB	A	B	C	D	E
<b>W 100 Fi</b>	1,000 mm	1,600 mm	2,540 mm	2,120 mm	1,925 mm	340 mm
<b>W 120 Fi</b>	1,200 mm	1,620 mm	2,660 mm	2,230 mm	2,075 mm	290 mm
<b>W 130 Fi</b>	1,300 mm	1,600 mm	2,760 mm	2,330 mm	2,190 mm	290 mm

<sup>1)</sup> Folding discharge conveyor, short

<sup>2)</sup> Based on operating weight, CE with conveyor folded out

MILLING RADIUS W 100 Fi, W 120 Fi, W 130 Fi AT MILLING DEPTH OF 150 MM

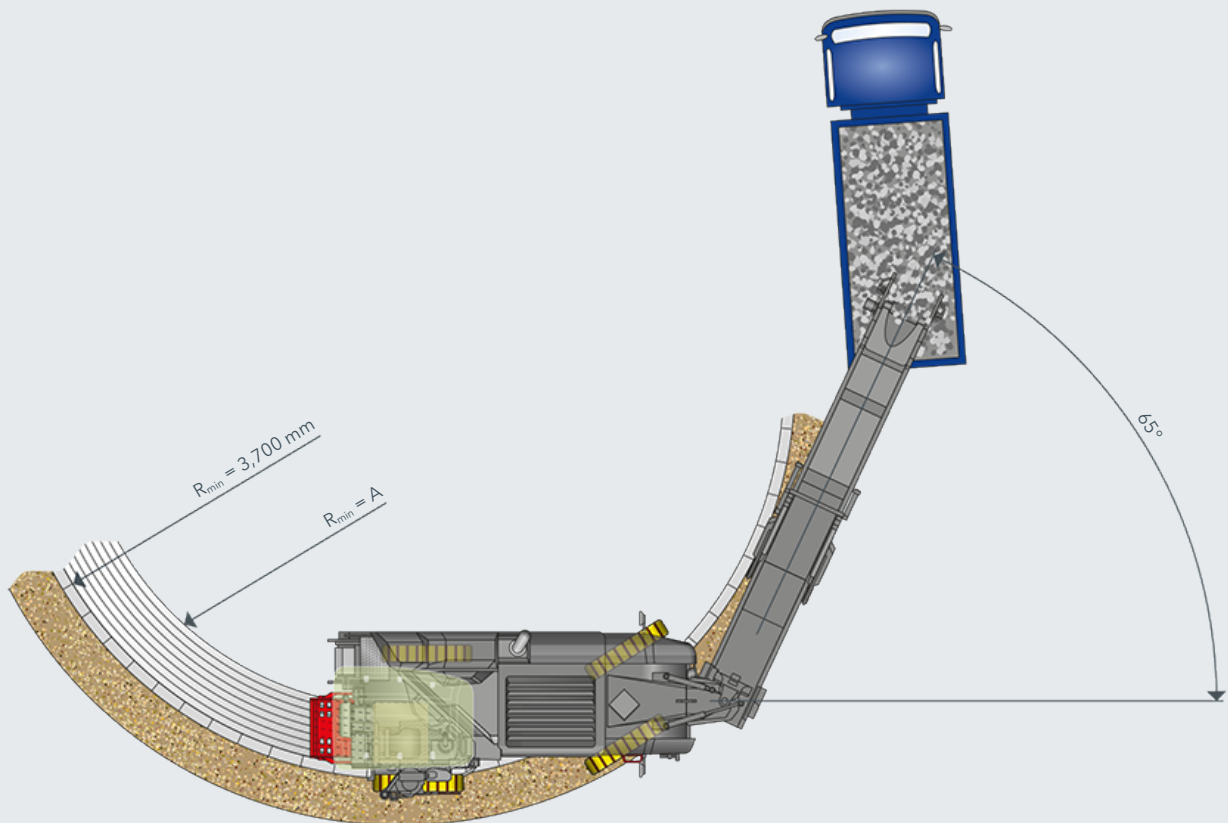

	<b>FB</b>	<b>A</b>
<b>W 100 Fi</b>	1,000 mm	2,700 mm
<b>W 120 Fi</b>	1,200 mm	2,500 mm
<b>W 130 Fi</b>	1,300 mm	2,500 mm



MILLING RADIUS W 100 Fi, W 120 Fi, W 130 Fi AT MILLING DEPTH OF 150 MM

---

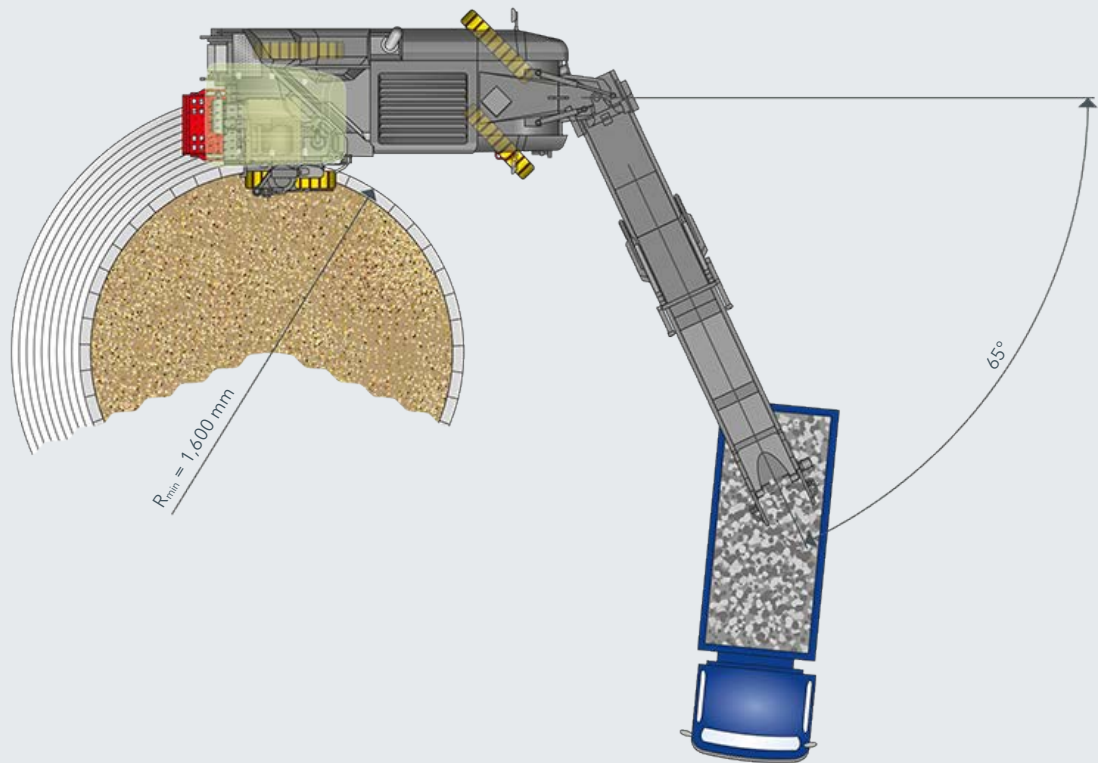

STANDARD EQUIPMENT	W 100 Fi	W 120 Fi	W 130 Fi
<b>Basic Machine</b>			
> Base machine with engine	■	■	■
> Electrohydraulically opening engine cowling	■	■	■
> Radiator with temperature-dependent fan speed	■	■	■
> Highly effective noise insulation throughout the engine compartment	■	■	■
> Automatic engine speed adjustment depending on machine load	■	■	■
> Elastically mounted engine station with low vibration and low noise	■	■	■
<b>Milling Drum Unit</b>			
> The right-hand side of the milling drum housing can be easily opened for maintenance or drum change	■	■	■
> Hydraulically operated rear scraper with mechanical locking	■	■	■
> Milling drum housing FB1000 Premium	□	—	—
> Milling drum housing FB1200 Premium	—	□	—
> Milling drum housing FB1300 Premium	—	—	□
<b>Milling Drums</b>			
> Milling drum FB1000 <b>HT22 PLUS</b> LA15 with 95 picks	□	—	—
> Milling drum FB1200 <b>HT22 PLUS</b> LA15 with 109 picks	—	□	—
> Milling drum FB1300 <b>HT22 PLUS</b> LA15 with 115 picks	—	—	□
<b>Loading of the Milled Material</b>			
> Discharge conveyor slewing angle left 65 degrees - right 65 degrees	■	■	■
> Hydraulically foldable discharge conveyor with two swing speeds, including adjustable conveyor speed for precise loading	■	■	■
> Machine with hydraulic pre-fitting for a discharge conveyor - screw coupling	□	□	□
> Discharge conveyor, 8,150 mm long, 600 mm wide, with hydraulic folding device	□	□	□
<b>Machine Control and Leveling System</b>			
> Digital milling depth indicator on machine control panel	■	■	■
> <b>LEVEL PRO ACTIVE</b> leveling system right and left	■	■	■
> RAPID SLOPE cross-slope sensor for <b>LEVEL PRO ACTIVE</b> leveling system	■	■	■
> Precise machine height adjustment in increments of 1 or 5 mm via the machine's main control panel	■	■	■
> Advance drive with electronic traction control system	■	■	■
> Automatic water management	■	■	■
<b>Operator's Platform</b>			
> Hydraulically extendable operator's platform for optimum view of the working area	■	■	■
> Steering console adjustable in inclination which enables the operator's platform to be ideally adjusted to suit the operator	■	■	■
> Slender machine design permits unobstructed view of the milled edge as well as the working area in front of the milling drum on the right	■	■	■
> Conveniently accessible ladder / footstep to the operator's platform with night-time lighting and especially low bottom edge of the latter / footstep	■	■	■
> Robust anti-vandalism protection for the controls	■	■	■
> Mirror package including front left and right rear-view mirrors, a forward-facing mirror to the left of the operator's platform, and a mirror for the area in front of the left front crawler unit	■	■	■
> Reversing horn with clearly audible signal	■	■	■
> Illuminated control panel / nighttime design	■	■	■
> Scraper height indicator on control panel	■	■	■
> Premium operator's platform, hydraulically moveable	□	□	□

STANDARD EQUIPMENT	W 100 Fi	W 120 Fi	W 130 Fi
<b>Track Unit and Height Adjustment</b>			
> Dual-speed hydraulic height adjustment of front and rear track units	■	■	■
> ISC - intelligent track speed control including hydraulic four-track drive	■	■	■
> Reversing with the milling drum rotating. Simple and fast maneuvering	■	■	■
> Equipped with extremely wear-resistant 2-piece polyurethane track pads	■	■	■
> 4 driven track units	□	□	□
<b>Miscellaneous</b>			
> Large tool package	■	■	■
> Towing device	■	■	■
> Generously sized water and diesel tanks	■	■	■
> Comprehensive safety package with several EMERGENCY STOP switches	■	■	■
> "Welcome-and-Go-Home-Light" feature including LED lighting in the area of the operator's platform and access	■	■	■
> Hydraulically driven water filler pump used to fill the water tank with a suction hose, maximum flow-through quantity of 210 l/m	■	■	■
> European type certification, EuroTest mark and CE conformity	■	■	■
> Standard film coating in RAL 9001 (cream)	□	□	□
> WITOS - professional telematics solution for machine operation and service optimization	□	□	□
> Standard LED lighting package with 14,050 lumen	□	□	□
> Standard electro-hydraulic unit	□	□	□

■ = Standard equipment

□ = Standard equipment, can be replaced with optional equipment if desired

□ = Optional equipment

OPTIONAL EQUIPMENT	W 100 Fi	W 120 Fi	W 130 Fi
<b>Milling Drum Unit</b>			
> Milling drum housing FB1000 FCS	<input type="checkbox"/>	—	—
> Milling drum housing FB1200 FCS	—	<input type="checkbox"/>	—
> Milling drum housing FB1300 FCS	—	—	<input type="checkbox"/>
> Overload sensor on the scraper	<input type="checkbox"/>	<input type="checkbox"/>	<input type="checkbox"/>
> Active floating position for the side plates, left and right	<input type="checkbox"/>	<input type="checkbox"/>	<input type="checkbox"/>
> Wear-protection rollers for right side plate	<input type="checkbox"/>	<input type="checkbox"/>	<input type="checkbox"/>
> Sectional, electrically switchable water spray bar for FB1000	<input type="checkbox"/>	<input type="checkbox"/>	<input type="checkbox"/>
> Hydraulic scraper board	<input type="checkbox"/>	<input type="checkbox"/>	<input type="checkbox"/>
<b>Milling Drums</b>			
> Milling drum FB1000 <b>HT22 PLUS</b> LA18 with 88 picks	<input type="checkbox"/>	—	—
> Milling drum FB1200 <b>HT22 PLUS</b> LA18 with 100 picks	—	<input type="checkbox"/>	—
> Milling drum FB1300 <b>HT22 PLUS</b> LA18 with 105 picks	—	—	<input type="checkbox"/>
> FCS milling drum FB1000 <b>HT22 PLUS</b> LA15 with 95 picks	<input type="checkbox"/>	—	—
> FCS milling drum FB1200 <b>HT22 PLUS</b> LA15 with 109 picks	—	<input type="checkbox"/>	—
> FCS milling drum FB1300 <b>HT22 PLUS</b> LA15 with 115 picks	—	—	<input type="checkbox"/>
> FCS milling drum FB1000 <b>HT22 PLUS</b> LA18 with 88 picks	<input type="checkbox"/>	—	—
> FCS milling drum FB1200 <b>HT22 PLUS</b> LA18 with 100 picks	—	<input type="checkbox"/>	—
> FCS milling drum FB1300 <b>HT22 PLUS</b> LA18 with 105 picks	—	—	<input type="checkbox"/>
> FCS milling drum FB1000 <b>HT22 PLUS</b> LA8 with 149 picks	<input type="checkbox"/>	—	—
> FCS milling drum FB1200 <b>HT22 PLUS</b> LA8 with 174 picks	—	<input type="checkbox"/>	—
> FCS milling drum FB1300 <b>HT22 PLUS</b> LA8 with 185 picks	—	—	<input type="checkbox"/>
> FCS milling drum FB1000 <b>HT5</b> LA6X2 with 340 picks	<input type="checkbox"/>	—	—
> FCS milling drum FB1200 <b>HT5</b> LA6X2 with 410 picks	—	<input type="checkbox"/>	—
> FCS milling drum FB1300 <b>HT5</b> LA6X2 with 444 picks	—	—	<input type="checkbox"/>
> FCS milling drum FB1000 <b>HT22 PLUS</b> LA25 with 83 picks	<input type="checkbox"/>	—	—
> FCS milling drum FB1200 <b>HT22 PLUS</b> LA25 with 87 picks	—	<input type="checkbox"/>	—
> FCS milling drum FB1300 <b>HT22 PLUS</b> LA25 with 91 picks	—	—	<input type="checkbox"/>
> FCS milling unit FB300 <b>HT22 PLUS</b> LA12 with 61 picks	<input type="checkbox"/>	<input type="checkbox"/>	<input type="checkbox"/>
> FCS milling unit FB500 <b>HT22 PLUS</b> LA15 with 72 picks	<input type="checkbox"/>	<input type="checkbox"/>	<input type="checkbox"/>
> FCS milling unit FB600 <b>HT22 PLUS</b> LA12 with 79 picks	<input type="checkbox"/>	<input type="checkbox"/>	<input type="checkbox"/>
> FCS milling unit FB900 <b>HT22 PLUS</b> LA15 with 102 picks	—	<input type="checkbox"/>	<input type="checkbox"/>
> FCS tandem scraper	<input type="checkbox"/>	<input type="checkbox"/>	<input type="checkbox"/>
> Milling drum assembly trolley to FB1300	<input type="checkbox"/>	<input type="checkbox"/>	<input type="checkbox"/>
> Assembly kit for moving the FCS milling drum	<input type="checkbox"/>	<input type="checkbox"/>	<input type="checkbox"/>
> Hydraulically driven pick extractor drift	<input type="checkbox"/>	<input type="checkbox"/>	<input type="checkbox"/>
> Milling drum rotation device	<input type="checkbox"/>	<input type="checkbox"/>	<input type="checkbox"/>
> Pneumatic hammer with pick extractor / inserter	<input type="checkbox"/>	<input type="checkbox"/>	<input type="checkbox"/>
<b>Loading Of The Milled Material</b>			
> Machine with hydraulic pre-fitting for a discharge conveyor - quick-change coupling	<input type="checkbox"/>	<input type="checkbox"/>	<input type="checkbox"/>
> Shortened discharge conveyor, 6,500 mm long, 600 mm wide, with hydraulic folding device	<input type="checkbox"/>	<input type="checkbox"/>	<input type="checkbox"/>
> Signal lights for visual "stop" and "go" instructions for the truck driver	<input type="checkbox"/>	<input type="checkbox"/>	<input type="checkbox"/>
> VCS extraction system	<input type="checkbox"/>	<input type="checkbox"/>	<input type="checkbox"/>
> Active Conveyor swing angle control for discharge conveyor	<input type="checkbox"/>	<input type="checkbox"/>	<input type="checkbox"/>

OPTIONAL EQUIPMENT	W 100 Fi	W 120 Fi	W 130 Fi
<b>Machine Control and Leveling System</b>			
> Leveling boom including sensor for <b>LEVEL PRO ACTIVE</b> leveling system	<input type="checkbox"/>	<input type="checkbox"/>	<input type="checkbox"/>
> Extension of <b>LEVEL PRO ACTIVE</b> with two leveling booms and one Sonic-Ski sensor	<input type="checkbox"/>	<input type="checkbox"/>	<input type="checkbox"/>
> Multiplex pre-equipment consisting of 2 sensor sockets	<input type="checkbox"/>	<input type="checkbox"/>	<input type="checkbox"/>
> 3-way multiplex system, right, including 2 ultrasonic sensors	<input type="checkbox"/>	<input type="checkbox"/>	<input type="checkbox"/>
> 3-way multiplex system, right and left, including 4 ultrasonic sensors	<input type="checkbox"/>	<input type="checkbox"/>	<input type="checkbox"/>
> Level control 3D leveling pre-equipment	<input type="checkbox"/>	<input type="checkbox"/>	<input type="checkbox"/>
> Extension of <b>LEVEL PRO ACTIVE</b> with a linear laser sensor	<input type="checkbox"/>	<input type="checkbox"/>	<input type="checkbox"/>
<b>Operator's Platform</b>			
> Operator's platform with air-conditioned comfort cabin	<input type="checkbox"/>	<input type="checkbox"/>	<input type="checkbox"/>
> Operator's platform equipped with weather protection elements on the sides	<input type="checkbox"/>	<input type="checkbox"/>	<input type="checkbox"/>
> Operator's platform with weather canopy and lateral weather protection elements	<input type="checkbox"/>	<input type="checkbox"/>	<input type="checkbox"/>
> Heating operator's platform	<input type="checkbox"/>	<input type="checkbox"/>	<input type="checkbox"/>
<b>Track Unit and Height Adjustment</b>			
> 4 driven wheeled chassis	<input type="checkbox"/>	<input type="checkbox"/>	<input type="checkbox"/>
<b>Miscellaneous</b>			
> Film coating according to the customer's wishes	<input type="checkbox"/>	<input type="checkbox"/>	<input type="checkbox"/>
> <b>WIRTGEN PERFORMANCE TRACKER</b> - Precise measurement of milling performance	<input type="checkbox"/>	<input type="checkbox"/>	<input type="checkbox"/>
> Model without WITOS	<input type="checkbox"/>	<input type="checkbox"/>	<input type="checkbox"/>
> Extended LED lighting package with 27,200 lumen	<input type="checkbox"/>	<input type="checkbox"/>	<input type="checkbox"/>
> Premium electro-hydraulic unit	<input type="checkbox"/>	<input type="checkbox"/>	<input type="checkbox"/>
> Additional weight 470 kg	<input type="checkbox"/>	<input type="checkbox"/>	<input type="checkbox"/>
> Air compressor system	<input type="checkbox"/>	<input type="checkbox"/>	<input type="checkbox"/>
> Electrical fuel filter preheating	<input type="checkbox"/>	<input type="checkbox"/>	<input type="checkbox"/>
> Powerful high-pressure water cleaner, 150 bar, 15 l/min	<input type="checkbox"/>	<input type="checkbox"/>	<input type="checkbox"/>
> User-specific storage of machine settings via SMART KEY key fob	<input type="checkbox"/>	<input type="checkbox"/>	<input type="checkbox"/>
> <b>MILL ASSIST</b> assistance system	<input type="checkbox"/>	<input type="checkbox"/>	<input type="checkbox"/>
> Monitor system with 2 cameras and a 7" control panel	<input type="checkbox"/>	<input type="checkbox"/>	<input type="checkbox"/>
> Monitor system with 5 cameras and a 10" control panel	<input type="checkbox"/>	<input type="checkbox"/>	<input type="checkbox"/>
> Expanded lighting equipment	<input type="checkbox"/>	<input type="checkbox"/>	<input type="checkbox"/>
> License plate holder with LED lighting	<input type="checkbox"/>	<input type="checkbox"/>	<input type="checkbox"/>

■ = Standard equipment

■ = Standard equipment, can be replaced with optional equipment if desired

□ = Optional equipment

**WIRTGEN GmbH**

Reinhard-Wirtgen-Str. 2  
53578 Windhagen  
Germany

T: +49 2645 131-0  
F: +49 2645 131-392  
E: [info@wirtgen.com](mailto:info@wirtgen.com)

 [www.wirtgen.de](http://www.wirtgen.de)



For further information, please scan the code.