

The benchmark for perfect concrete paving in the 32 ft class.  
**SP 94i Slipform Paver**

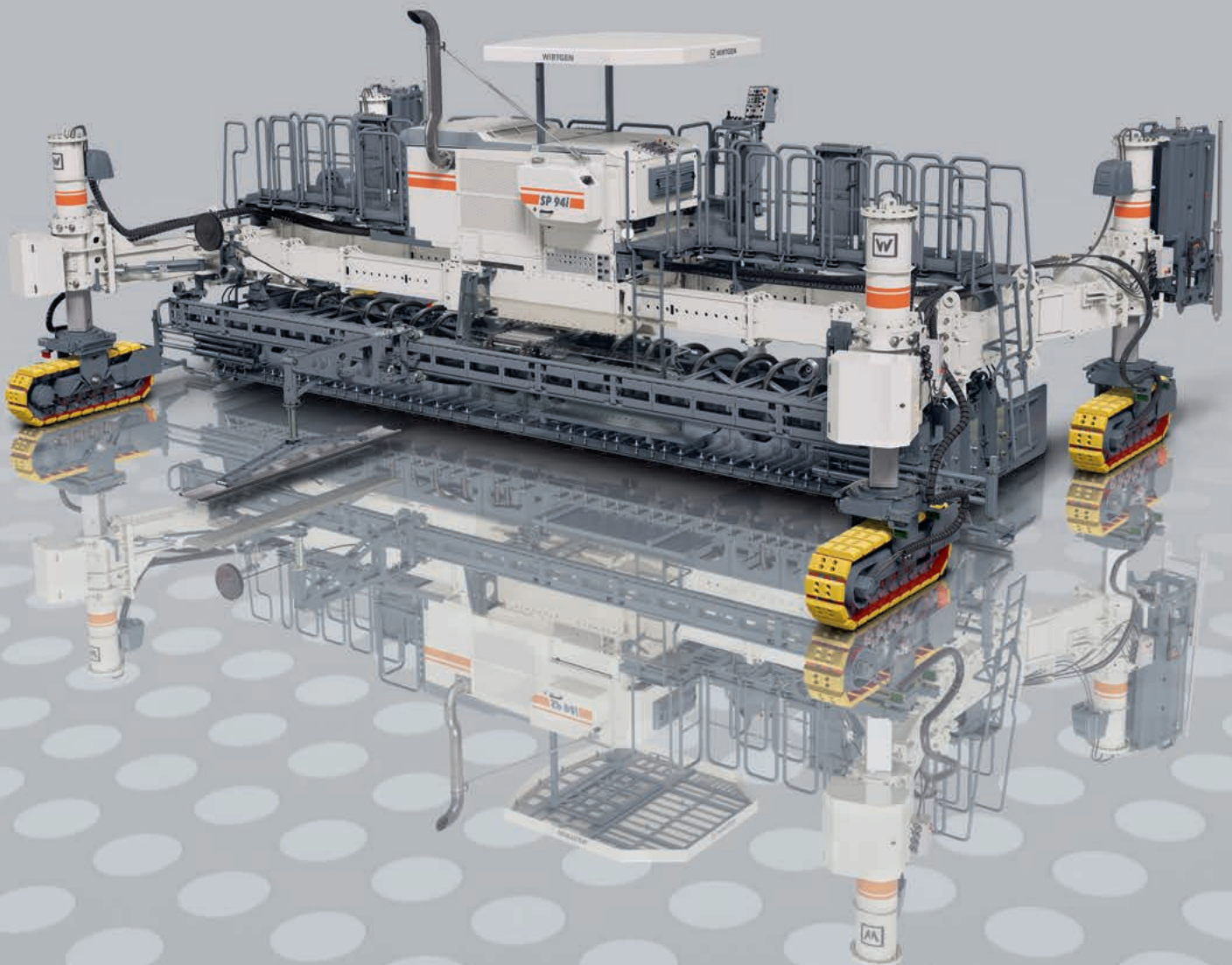

# Highlights of the SP 94i at a Glance

02  
03

## Machine Concept

### 1 | RUGGED MACHINE DESIGN

The machine's rugged design guarantees consistent, high-output concrete paving and precise paving results, even under difficult site conditions.

### 2 | FULLY MODULAR MACHINE DESIGN

The machine's fully modular design means it's possible to flexibly modify, upgrade with new options, and adapt the machine to the specific job site situation.

### 3 | SOPHISTICATED TRANSPORT CONCEPT

Compact dimensions and minimal time and effort needed to prepare the machine make loading easy and transport cost-effective. Depending on the configuration, the dowel bar inserter or oscillating beam, super smoother, and concrete spreader can remain mounted to the machine during transport.

- > Rugged 4-track paver with an enormous range of applications in the construction of roads and airfields with a working width of up to 32 ft
- > Precise insertion of dowels and tie bars
- > Creates an exceptionally flat surface

## Concrete Unit

### 4 | HIGHLY FLEXIBLE CONCRETE PAVING

The standard version of the slipform paver is capable of paving perfect and precise concrete surfaces from 6 ft to 32 ft wide\* and up to 18 in (450 mm) thick.

### 5 | TRIED-AND-TESTED PAVING MOLD

Compatible with the 1300 wi series of imperial inset paving molds. The 1300 wi series comes standard with a wear sole and can be equipped with an optional crown feature.

### 6 | REINFORCEMENT INSERTION BUILT INTO THE MACHINE

A self-loading dowel bar inserter, central bar inserter(s), and side tie bar inserter(s) are available on request.

### 7 | ALTERNATIVE CONSOLIDATION TECHNOLOGY

Depending on site requirements, the machine can be equipped with a hydraulic or electric vibrator drive. The machine comes standard with 12 hydraulic connections (optional: 18 or 24), with 12, 20, or 28 electrical connections optional.

\* = Paving width with central crown: 12 ft to 32 ft

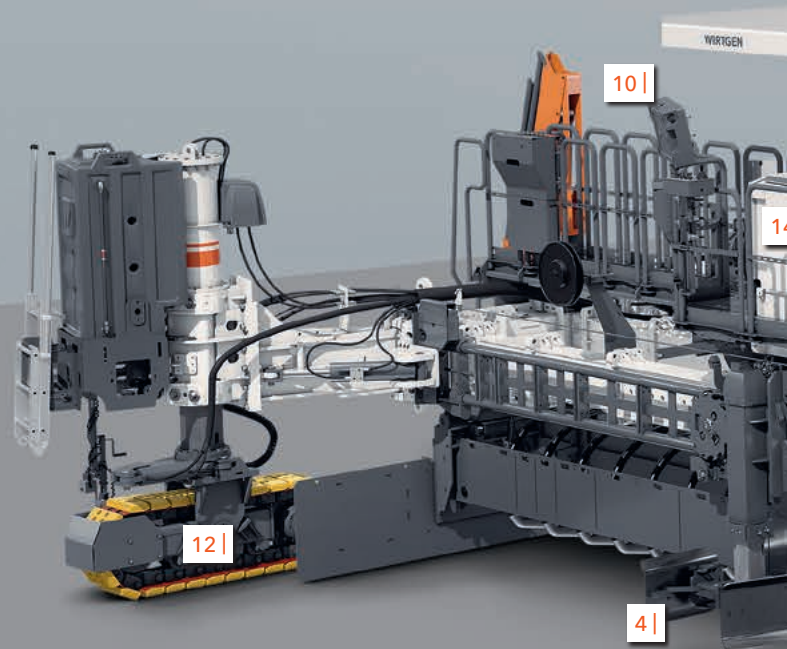

## Engine Technology and Operation

### 8 | COST-EFFECTIVE ENGINE MANAGEMENT

The "ECO Mode" setting automatically adjusts engine power to the current performance requirements to ensure fuel-efficient diesel consumption and low noise emissions.



## Control and Steering

### 11 | HIGH-PRECISION STEERING AND DRIVE SYSTEMS

Intelligent steering and control systems for extremely smooth operation - even around tight curves - make high-precision concrete paving possible.

### 12 | PRODUCTIVITY-ENHANCING STEERING

Numerous optional and standard steering features, like hydraulic swivel arms and the innovative worm gear steering, significantly increase site productivity.

### 13 | MACHINE CONTROL SYSTEMS FEATURING ADVANCED INTELLIGENCE

WIRTGEN's efficient WITOS FleetView telematics system supports fleet management, position and status monitoring, as well as maintenance and diagnostic processes.

### 14 | FIELD-PROVEN 3D INTERFACE

The field-proven interface guarantees tested compatibility with leading suppliers' 3D control systems.

NEED MORE INFORMATION?

Have a look at our product animations.

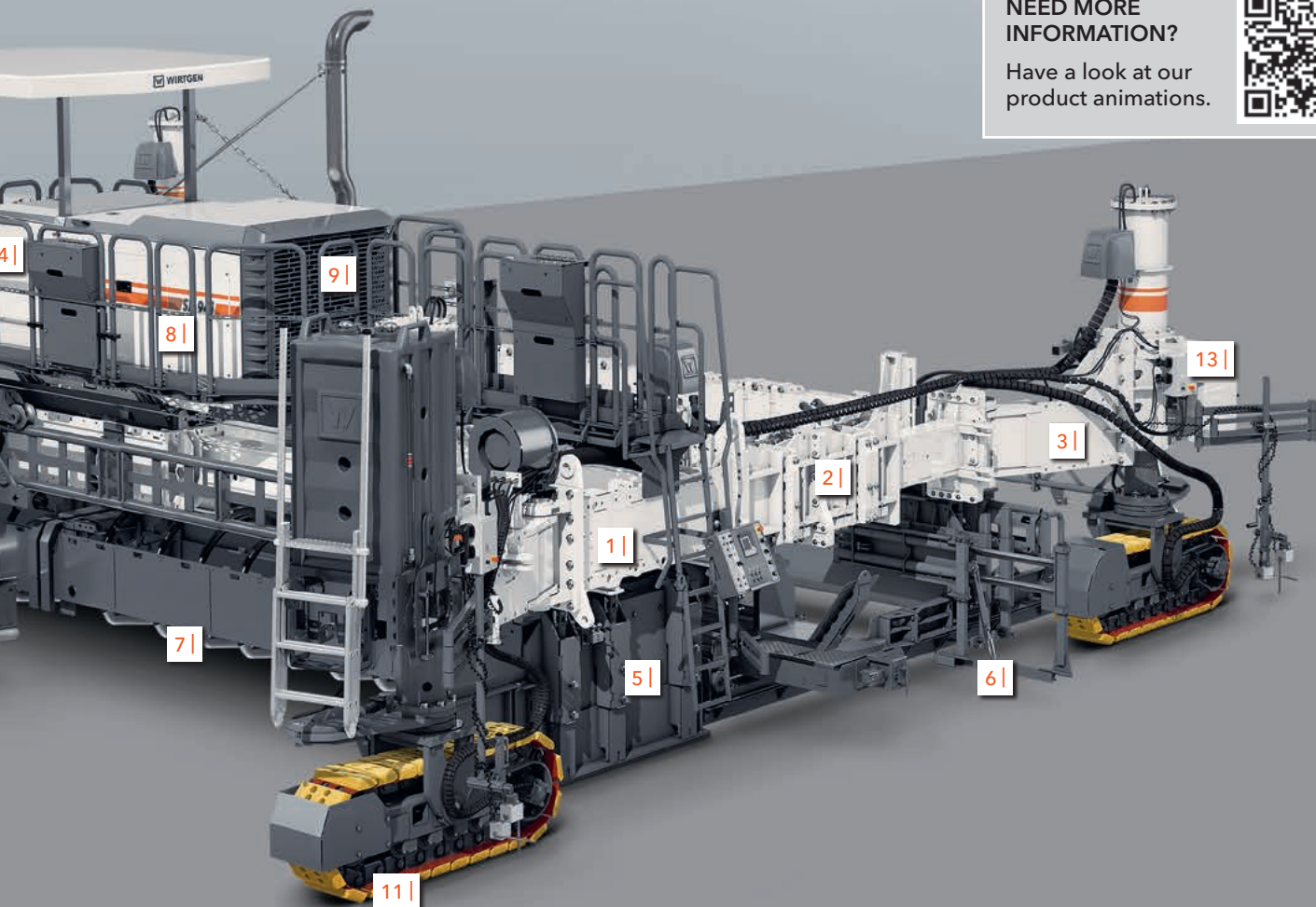

### 9 | STATE-OF-THE-ART ENGINE TECHNOLOGY

The SP 94i features cutting-edge, high-performance engine technology (231 kW/310 HP/314 PS) that meets EU Stage IV/US EPA Tier 4f emissions standards.

### 10 | PERFECT ERGONOMICS AND HANDLING

The ergonomically designed operator's platform, the standardized, intuitive operating concept for all SP series' models, and exceptional visibility makes the job easier for the operator.

# Machine Concept

04  
05

## TELESCOPING MACHINE FRAME

The machine frame, which can be extended both lengthwise and sideways, allows the operator to adapt the machine to the requirements of the job site.

## EASY UPGRADING

Standard interfaces allow the machine to be upgrading with individual options at any time.

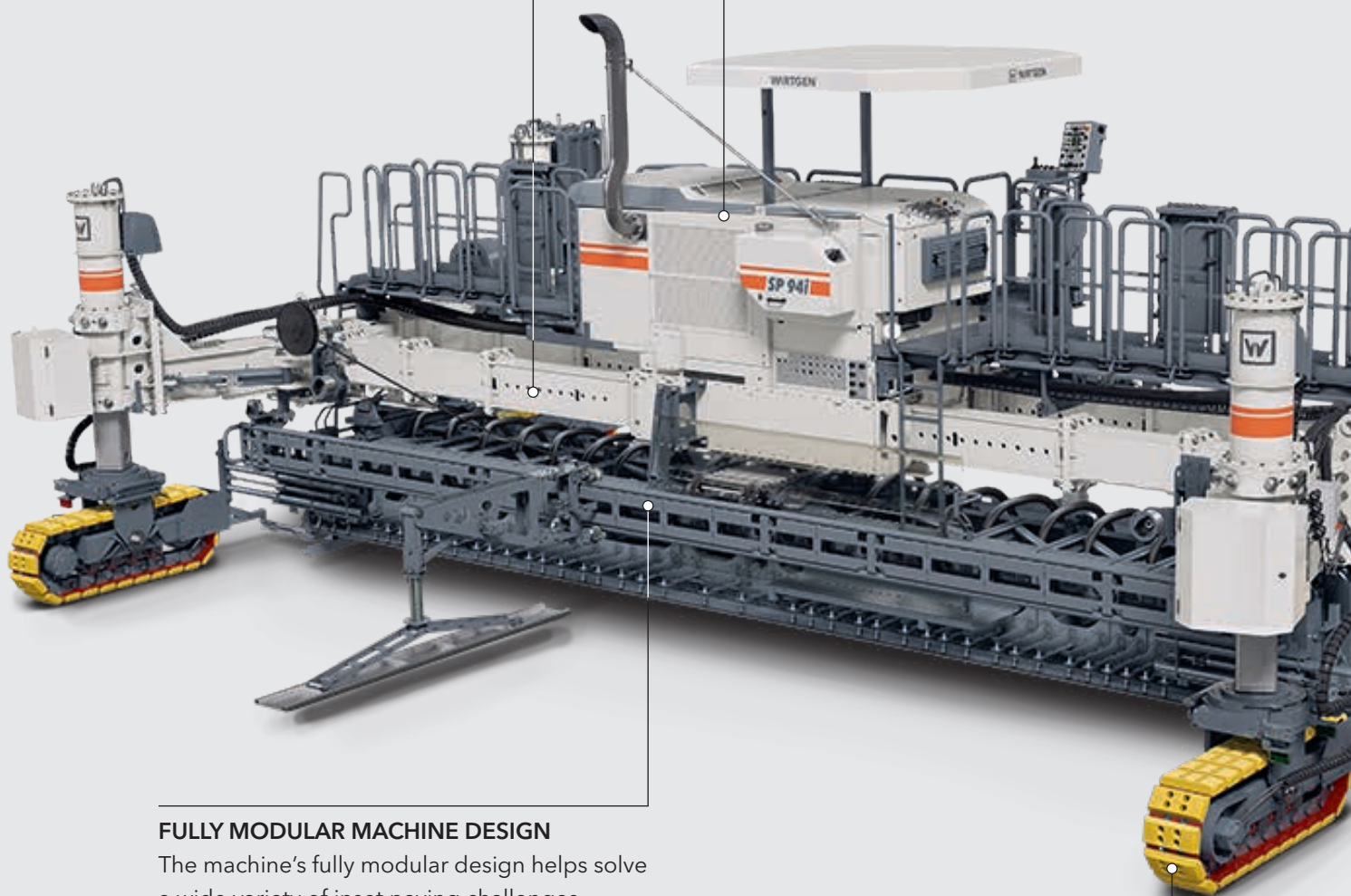

## FULLY MODULAR MACHINE DESIGN

The machine's fully modular design helps solve a wide variety of inset paving challenges.

## SLEWING CRAWLER UNITS

Crawler units with a wide slewing angle guarantee maximum flexibility on the job site.

### **RUGGED DESIGN**

The extremely rugged design of the machine frame, track units, and swivel arms makes high-precision paving results at maximum daily production rates possible.

### **OPTIMUM MACHINE WEIGHT**

The intelligently adjusted machine weight results in a balanced combination of stable paving behavior and excellent transportability.

### **RAPID CONVERSION DURING TRANSPORT**

The four movable swing legs (hydraulic legs available as an option) make it possible to switch quickly from transport to working mode and provide a great deal of flexibility when setting up the machine at a job site.

### **EASY TRANSPORT**

Maneuverability and compact machine dimensions make transport as easy as possible.

### **CUSTOMIZABLE MACHINE TECHNOLOGY**

The ability to reliably adapt the machine technology to the respective job site situation increases both its range of applications and productivity.



### **SIMPLE CONVERSION**

Easily convert and expand the machine with additional components to solve complex, customer-specific applications.

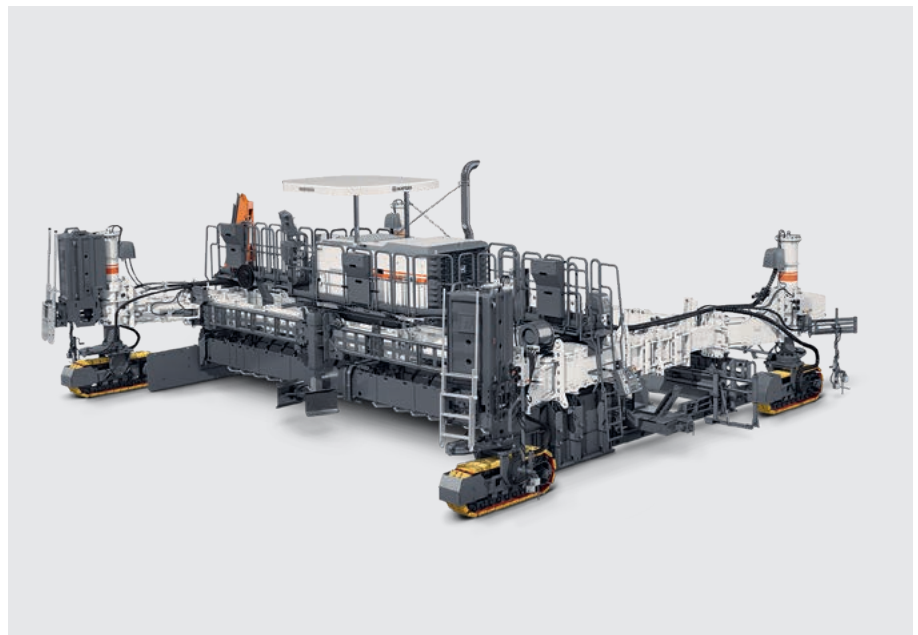

*Rugged machine design for high-output, precise concrete paving.*



# Concrete Unit

## CONCRETE SURFACING WITH CROWN PROFILE

A concrete surface can be easily produced with a crown profile of 3% or multiple crown profiles (available as an option).

## TAMPER BAR AND GROUT BOX AUGER

The continuous stroke movement of the tamper bar helps to ensure a uniform flow of concrete across the entire paving width. The grout box auger uniformly distributes the sludge that builds up in the case of a cross slope across the entire paving width in front of the paving mold.

## SPREADER PLOW OR AUGER

A spreader plow or spreading auger ensures that the concrete deposited in front of the mold is spread evenly.

## SUPER SMOOTHER

The oscillating super smoother made of high-quality material ensures perfect surface quality. And it does not have to be dismantled for transport.

## OPEN METERING GATE

The metering gate can be operated open or closed on both sides and also helps to ensure uniform concrete paving.

## IMPERIAL PAVING MOLDS

The 1300 wi series' imperial inset paving molds with wear soles guarantee professional concrete paving with stiff concrete consistency. Also available with the option of hydraulic ESC edge slump control for high-quality paving results.

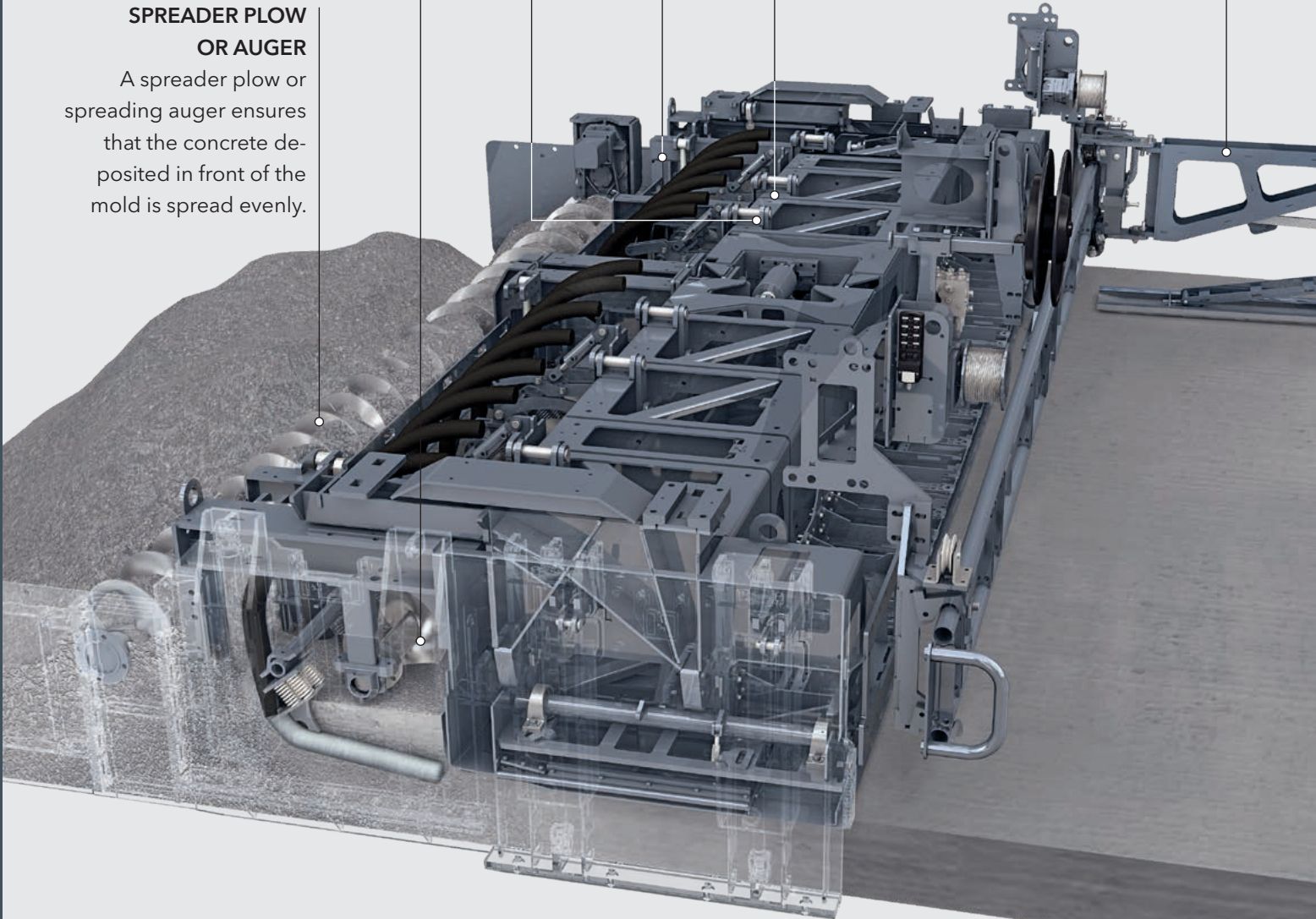

### **OSCILLATING BEAM**

In the case of concrete paving with a dowel bar inserter, the eccentric-powered, heavy-duty oscillating beam with automatic lifting function when the machine stops removes any irregularities in the concrete surface.

### **PAVING THICKNESS OF UP TO 18 IN (450 MM)**

Paving up to 18 in (450 mm) thick - greater paving thicknesses also possible upon request.

### **CONCRETE SURFACES 12 FT TO 32 FT WIDE**

Precise, high-quality paving of road surfaces and areas from 12 ft to 32 ft wide.

### **HYDRAULIC VIBRATORS**

The machine comes standard with 12 hydraulic connections to power the hydraulic vibrators (18 or 24 optionally available).

### **ELECTRIC VIBRATORS**

The machine can be equipped with either 12, 20, or 28 electrical connections to power the electric vibrators.

### **SEPARATE SIDE TIE BAR INSERTERS**

The side tie-bars facilitate paving of adjacent lanes and stop the lanes drifting apart.

### **AUTOMATIC LONGITUDINAL TIE BAR INSERTER**

Longitudinal tie bars are inserted automatically to prevent the slabs from drifting apart at the longitudinal joints.

### **CONTROL UNIT FOR LONGITUDINAL TIE BAR INSERTER**

A separate control unit for each longitudinal tie bar inserter makes adjustments at the job site easy.



*Separate side tie bar inserter.*

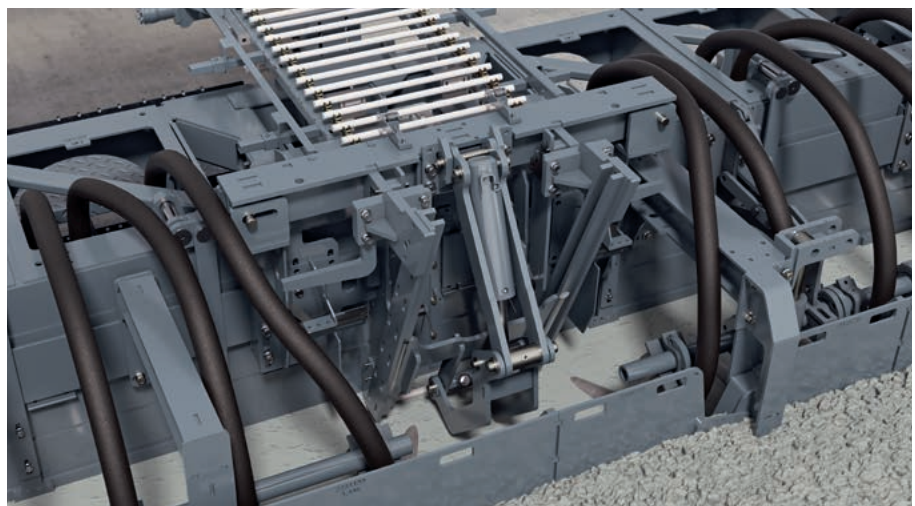

*Centrally positioned longitudinal tie bar inserter.*



# Concrete Unit

## AUTOMATED DOWEL BAR INSERTION PROCESS

After manually loading the dowel distribution trolley, dowels are distributed automatically at the touch of a button and the dowel insertion process is fully automatic.

## EFFECTIVE DOWEL BAR INSERTER

The inserted dowels secure the height of adjacent slabs and transfer shear forces from slab to slab.

## OPTIMIZED DOWEL BAR INSERTION PROCESS

The combination of hydraulic cylinders with a built-in position measuring system and proportional valves optimizes the dowel bar insertion process and the accurate positioning of the dowel bars in the already consolidated concrete. Paving concrete with support cages simplifies site logistics and thus considerably reduces material and process costs.

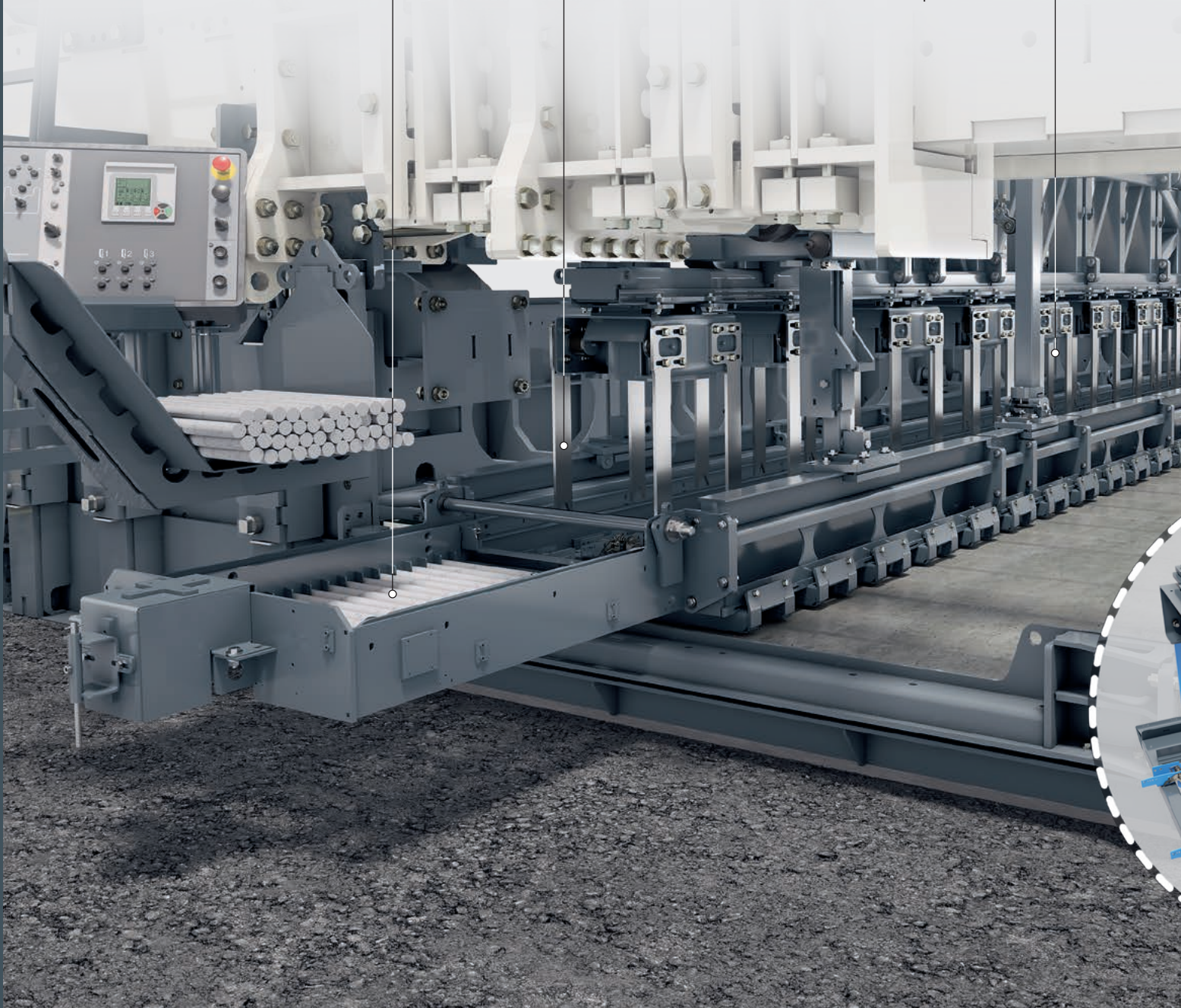



### MINIMUM EFFORT WITH VARYING DOWEL-BAR PLAN

The dowel bar inserter's modular design makes it easy to modify the dowel-bar plan (number, spacing, length, diameter of dowels) and requires very little effort to reconfigure the machine.

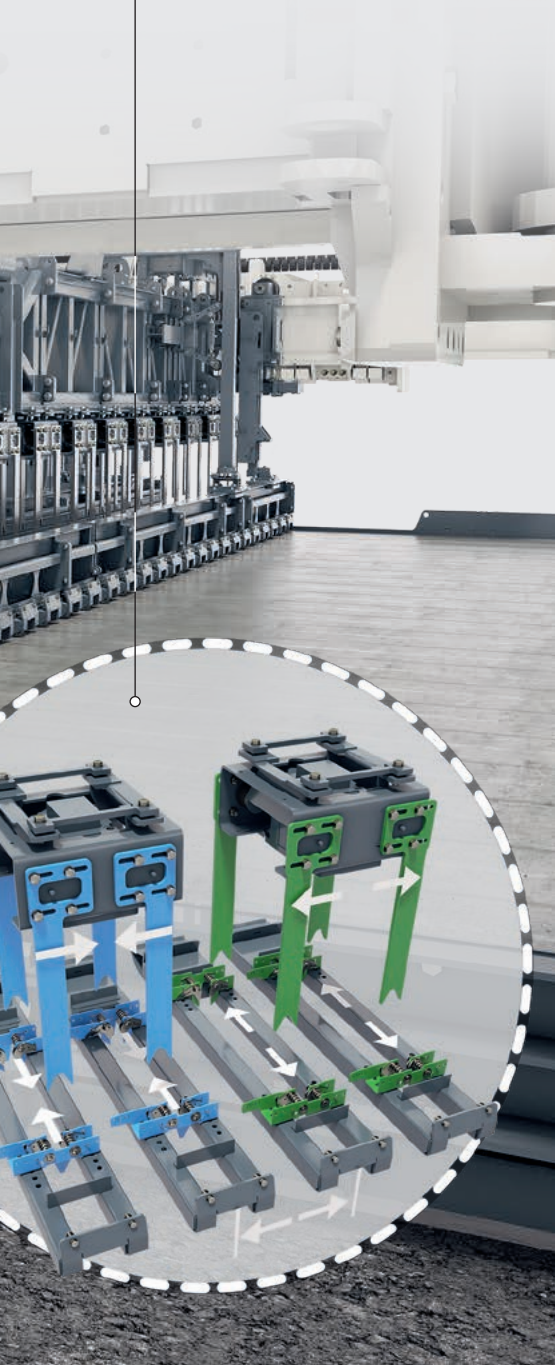

### BUILT-IN POSITION MEASURING SYSTEM FOR DISTANCE MEASUREMENT

Sensors built into the crawler units accurately determine the distance traveled and special software determines the distance between the next row of dowels or the next tie bar in the concrete.

### OPTIMALLY INTEGRATED CONTROL

The dowel bar inserter's control system is fully integrated into the slipform paver's flexibly expandable CAN bus system.

### SEPARATE CONTROL PANEL FOR INSERTERS

The control panel with innovative software and a standardized operating concept for all SP series is fully integrated into the machine control system. It can be moved to any position and makes it easy to enter the dowel-bar plan and the dowel bar and tie bar inserters' insertion parameters.

### SELF-LOADING DOWEL BAR INSERTER

The innovative self-loading technology makes it easy to transport the machine and quickly set it up on site without the need for expensive loading cranes. The heavy-duty hydraulic cylinders remain mounted on the dowel bar inserter both during transport and when in operation.

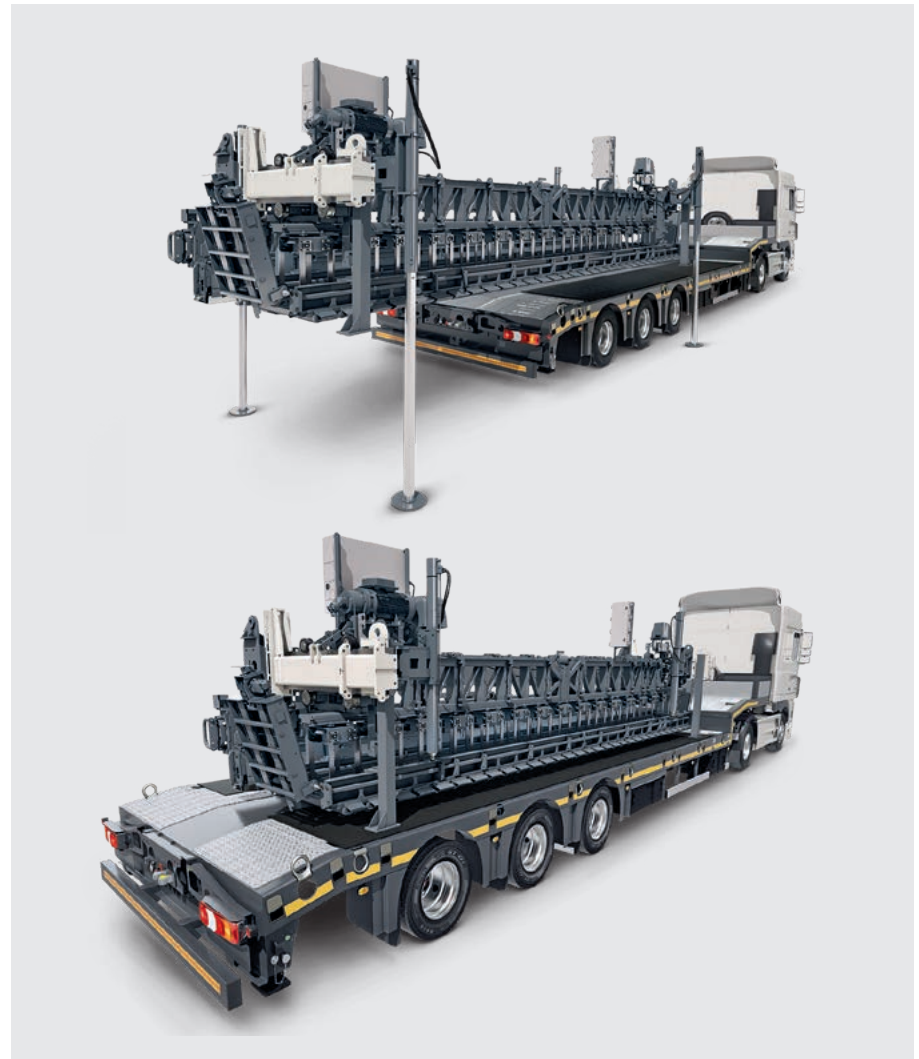

Self-loading dowel bar inserter.

# Engine Technology and Operation

10  
11

## ERGONOMICS

The ergonomically designed operator's platform increases the operator's performance and thus the productivity of the entire machine.

## STATE-OF-THE-ART CONTROL PANEL

With its state-of-the-art screen and clear, language-neutral symbols, the control panel promotes productive on-site operations.





**PERFORMANCE-OPTIMIZED  
AND OPERATOR-FRIENDLY ECO  
MODE ENGINE MANAGEMENT**

Automatically adapting engine output according to performance requirements guarantees optimum engine efficiency, economical diesel consumption, and low noise emissions. The ECO mode detects every working situation without any operator intervention.

**STANDARDIZED  
OPERATING CONCEPT**

The standardized, self-explanatory operating concept used on all the different SP series' models offers additional synergy effects.

**ENGINE TECHNOLOGY FOR EU STAGE IV/US EPA TIER 4f**

The SP 94 i's powerful diesel engine meets the stringent requirements of the EU Stage IV/US EPA Tier 4f emissions standards.

**POWERFUL ENGINE**

The powerful engine guarantees effective concrete paving in the optimum power and torque range at all times.

**PERFECT VISIBILITY**

The spacious operator's platform with additional folding platform provides a perfect view of the paving process.

**TELESCOPING WEATHER CANOPY**

The weather canopy can be extended electro-hydraulically, even when the engine is switched off, allowing the operator to work in all weather conditions.

**FAST MAINTENANCE**

Easy access to the maintenance and inspection points minimizes maintenance requirements.



*Ergonomically optimized, clearly organized control panel.*

# Control and Steering

12  
13

## HIGH-PRECISION DRIVE CONTROL

The high-precision control of the advance motors guarantees jerk-free travel, even at minimum speed.

## STEERING ANGLE SENSOR ADJUSTMENT

On the SP 94i, the steering angle positions of the four track units are adjusted fully automatically to optimize driving performance and thus precise concrete paving.

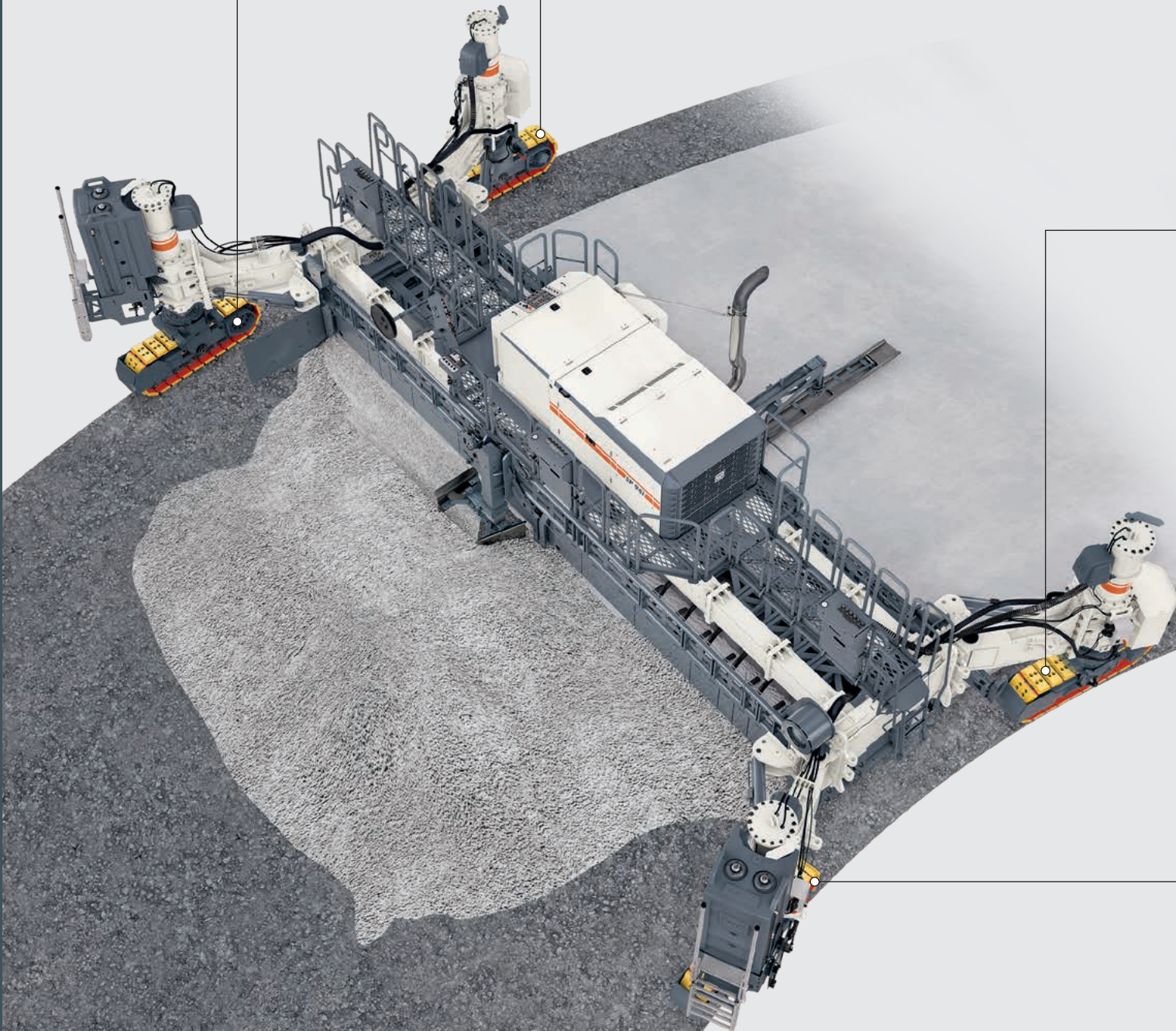



### HIGH-QUALITY MACHINE CONTROL SYSTEM

The high-quality machine control system using proprietary software increases both operating safety and the slipform paver's range of applications.

### SERVICE DIAGNOSTICS SYSTEM

WIDIAG, the service diagnosis system with a standardized interface, allows technicians to quickly troubleshoot errors directly on site.

### EXTENSIBLE CAN-BUS SYSTEM

The standard CAN bus system can be expanded to easily upgrade with new options.

### EFFICIENT WITOS TELEMATICS SYSTEM

WIRTGEN's WITOS FleetView telematics system supports fleet management, position and status monitoring, as well as maintenance and diagnostic processes.

### STANDARDIZED, OPTIONAL INTERFACE FOR 3D CONTROLS

The built-in standard interface perfectly meets the requirements for concrete paving using state-of-the-art 3D systems. Thorough acceptance procedures to ensure compatibility with 3D control systems from leading suppliers guarantee a high degree of operational reliability.

### SPEED ADJUSTMENT

The computer-assisted speed adjustment of each individual track unit enables specifications to be adhered to with pinpoint precision, even when paving around curves.

### FOUR STEERING MODES

Four different steering modes make turning and maneuvering easy.

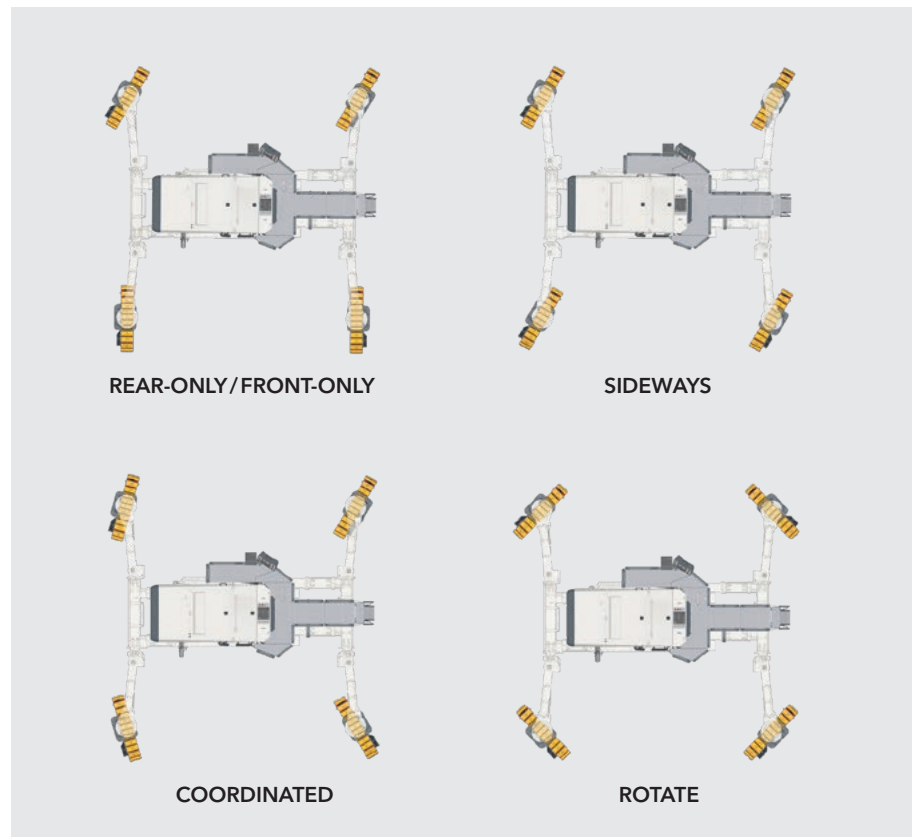

*Different steering modes available on the SP 94i.*

# Control and Steering

## INNOVATIVE WORM GEAR STEERING

The crawler units' steering angles of up to 100° to the left and 160° to the right increase flexibility, such as the ability to easily approach obstacles, particularly on tight job sites.

## CRAB MODE WITH TRACK UNITS AT A STEERING ANGLE OF 90° TO THE SIDE

Worm gear steering allows the machine to move sideways with the crawler units rotated by 90°. At the same time, this reduces time-consuming manual paving at the end of the lane, which is often necessary on cramped sites, to a minimum.

## ROTATING AROUND ITS OWN AXIS

Rotating the machine around its own axis by means of widely slewable crawler units eliminates the need for time-consuming turning maneuvers in confined construction site conditions.

## PAVING PLUS PACKAGE

The additional sensors that can be integrated into the swivel arms optimize machine control.

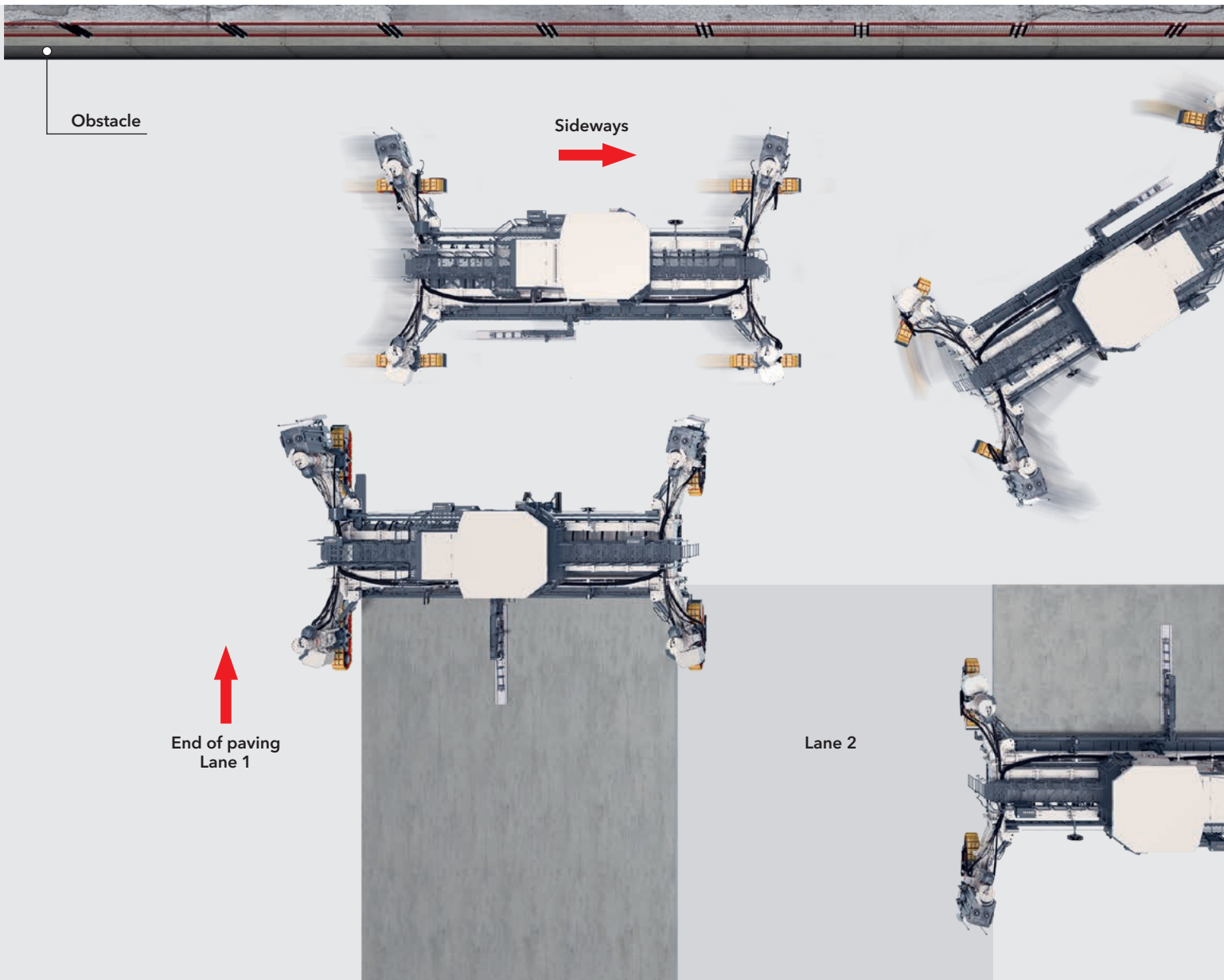



**HYDRAULICALLY ADJUSTABLE SWIVEL ARMS FOR EASY TRANSPORT**

The ability to quickly switch all four swivel arms from the transport to the operating position and vice versa within just a few minutes greatly simplifies machine transport.

**HYDRAULICALLY ADJUSTABLE SWIVEL ARMS FOR INCREASED ERGONOMICS**

The ability to hydraulically adjust the swivel arms without the need for much force increases ergonomics and user-friendliness.

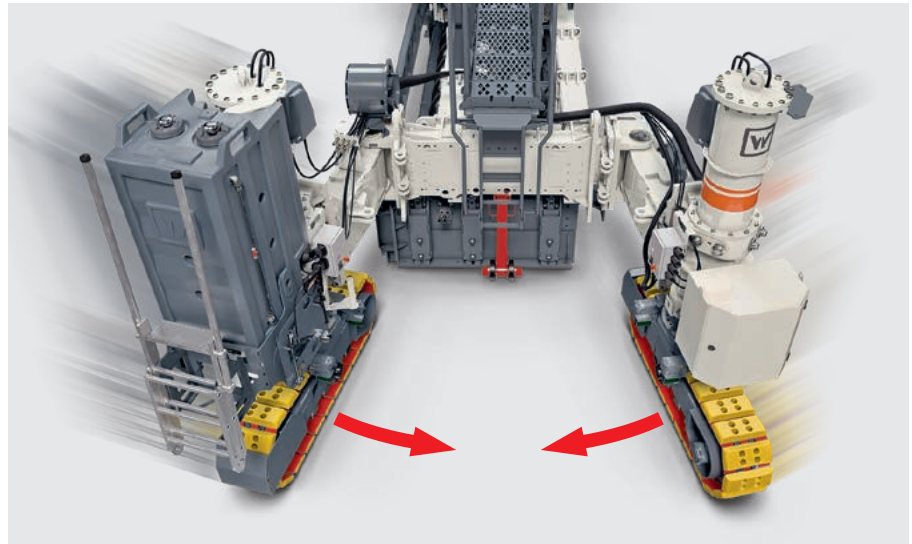

180° rotation



Paving Lane 3



*Hydraulic swivel arms for easy transport and a high degree of flexibility on the job site.*

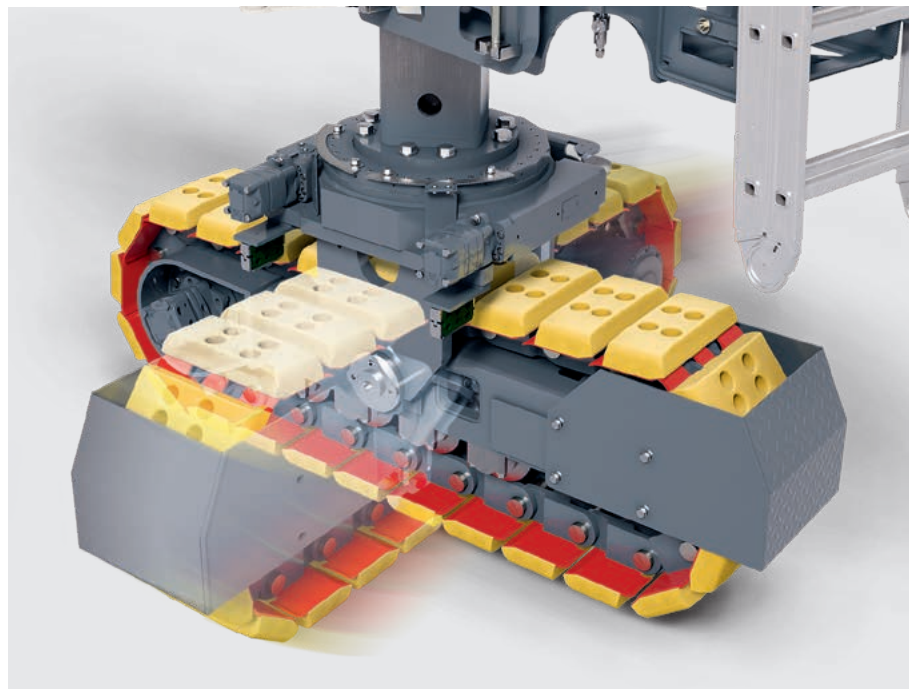

# Technical Specifications

## SP 94i

Range of Applications	
Slab paving application without central crown	Paving width: 6 ft to 32 ft* <sup>1</sup> Layer thickness: up to 18 in (450 mm)* <sup>1</sup>
Slab paving application with central crown	Paving width: 12 ft to 32 ft* <sup>1</sup> Layer thickness: up to 18 in in (450 mm)* <sup>1</sup>
Concrete Spreading	
Spreading auger	Modular extension to up to 32 ft
Spreading plow	Modular extension to up to 32 ft
Slab Paving Equipment	
Slab paving mold type 1300 wi (including wearing pan, including or excluding crown function)	Modular extension to up to 32 ft
Dowel bar inserter (DBI)	Modular extension to up to 32 ft
Oscillating beam	Modular extension to up to 32 ft* <sup>2</sup>
Super smoother	Modular extension to up to 32 ft
Longitudinal joint tie bar inserter in front of mold	1 or 2
Side tie bar inserter	Right and/or left
Vibrators and Circuits	
Hydraulic vibration	12 connectors (optional: 18 or 24 connectors)
Electric vibration	12 connectors (optional: 20 or 28 connectors)
Hydraulically driven vibrators	Curved (D66)
Electrically driven vibrators	Curved (D76)
Engine	
Engine manufacturer	Cummins
Type	QSL9 C-310
Cooling	Water
Number of cylinders	6
Rated power at 2,100 rpm	231 kW/310 HP/314 PS
Displacement	543 in <sup>3</sup> (8,900 cm <sup>3</sup> )
Fuel consumption, full load	16.5 gal/h (62.5 l/h)
Fuel consumption, <sup>2</sup> / <sub>3</sub> load	11.0 gal/h (41.7 l/h)
Exhaust emission standards	EU Stage IV/US EPA Tier 4f
Electrical System	
Electrical power supply	24 V DC
Electric vibration	110 V AC 3~/200 Hz



Tank Capacities	
Fuel	132 gal (500 l)
AdBlue®/DEF *2	15 gal (57 l)
Hydraulic oil, electric vibration	66 gal (250 l)
Hydraulic oil, hydraulic vibration	100 gal (380 l)
Water	145 gal + 145 gal (550 l + 550 l)
Driving Properties	
Paving speed	0 to 23 ft/min (0 to 7 m/min)
Travel speed in travel gear	0 to 72 ft/min (0 to 22 m/min)
Crawler Units	
Number	4
Type B4: dimensions (L x W x H)	6 ft 10 in x 14 in x 28 in (2,090 x 350 x 712 mm)
Height Adjustment	
Hydraulic	3 ft 3 in (1,000 mm)
Mechanical	18 in in (470 mm)
Central Crown	
Variable adjustment range	For paving widths of 6 ft to 26 ft: max. 3% *3 For paving widths of 26 ft to 32 ft: max. 2% *3
Transport Dimensions (L x W x H)	
Paving width 12 ft: Machine including slab paving mold type 1300 wi, including spreading plow and super smoother	30 ft 2 in x 9 ft 10 in x 10 ft 2 in (9,200 x 3,000 x 3,100 mm)
Paving width 30 ft: Machine including slab paving mold type 1300 wi, including spreading plow and super smoother	49 ft 10 in x 9 ft 10 in x 10 ft 2 in (15,200 x 3,000 x 3,100 mm)
Machine Weights	
Operating weight CE (including slab paving mold type 1300 wi), 12 ft	57,365 lb (26,020 kg)*4
Machine weight	52,910 lbs to 143,300 lb (24,000 to 65,000 kg)*5

\*1 = Please consult factory for special paving widths, layer thicknesses, and optional equipment features

\*2 = AdBlue® is a registered trademark of the German Association of the Automotive Industry (Verband der Automobilindustrie e. V.; VDA)

\*3 = Values within standard transport height; please consult factory for special dimensions

\*4 = Weight of machine, half weight of all operating materials, on-board tools, machine operator (165 lb (75 kg)), no optional equipment features

\*5 = Weights depend on the paver's range of equipment and paving width

# Dimensions

## SP 94i

Paving situation: slipform paver SP 94i equipped with spreading auger or spreading plow, slab paving mold type 1300 wi, and super smoother

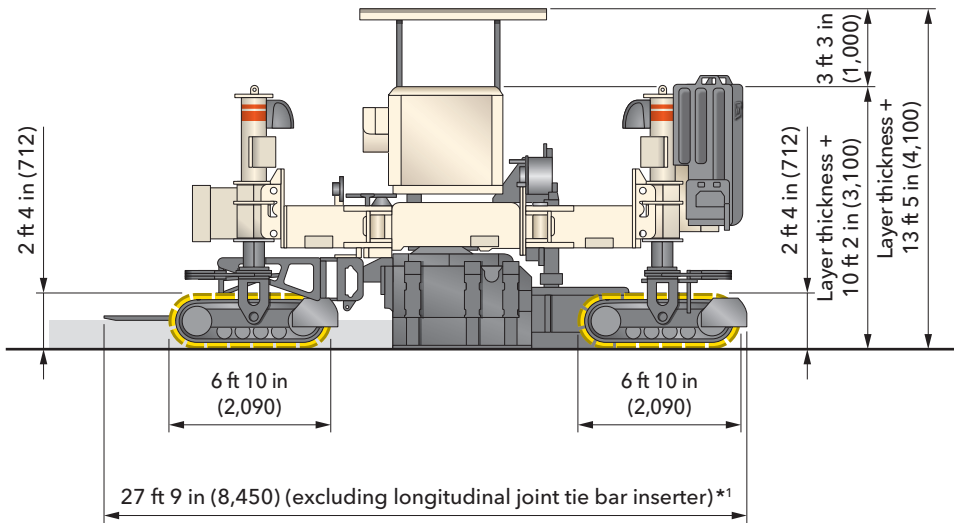

Working direction

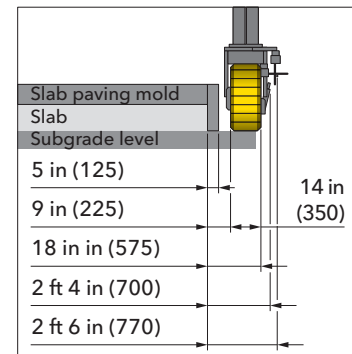
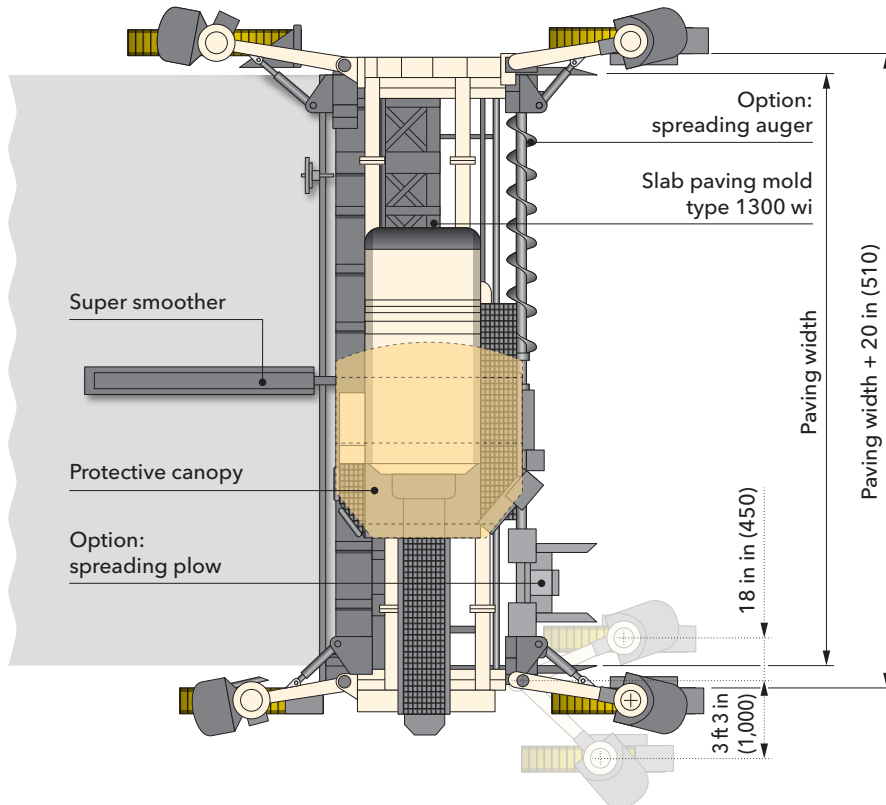

Minimum space required for track units at a paving width  $\geq$  9 ft 10 in (3.0 m) (excluding side tie bar inserter)

Dimensions in American standard and mm

\*1 = Longitudinal joint tie bar inserter and side tie bar inserter not shown



Paving situation: slipform paver SP 94i equipped with spreading auger or spreading plow, slab paving mold type 1300 wi, dowel bar inserter (DBI), oscillating beam, and super smoother

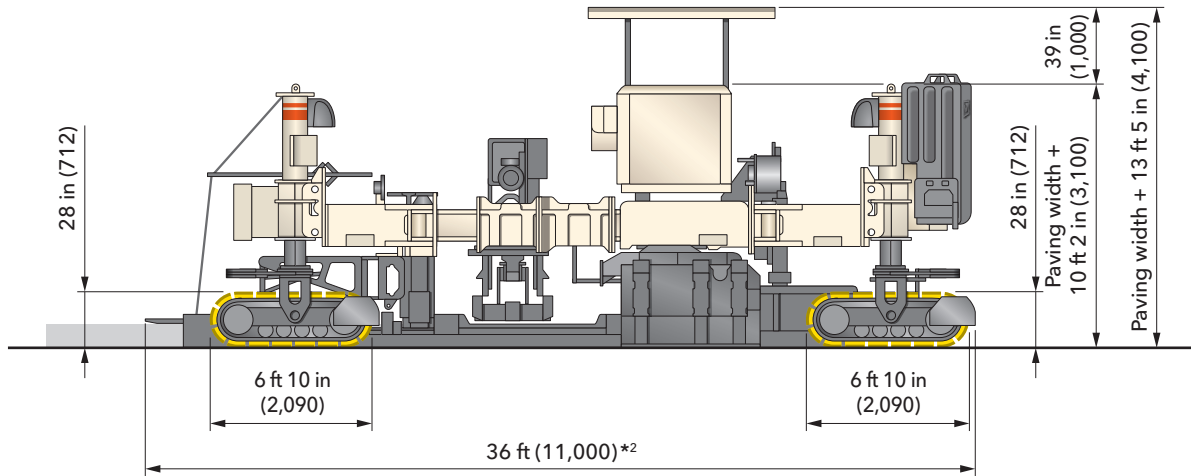

Working direction

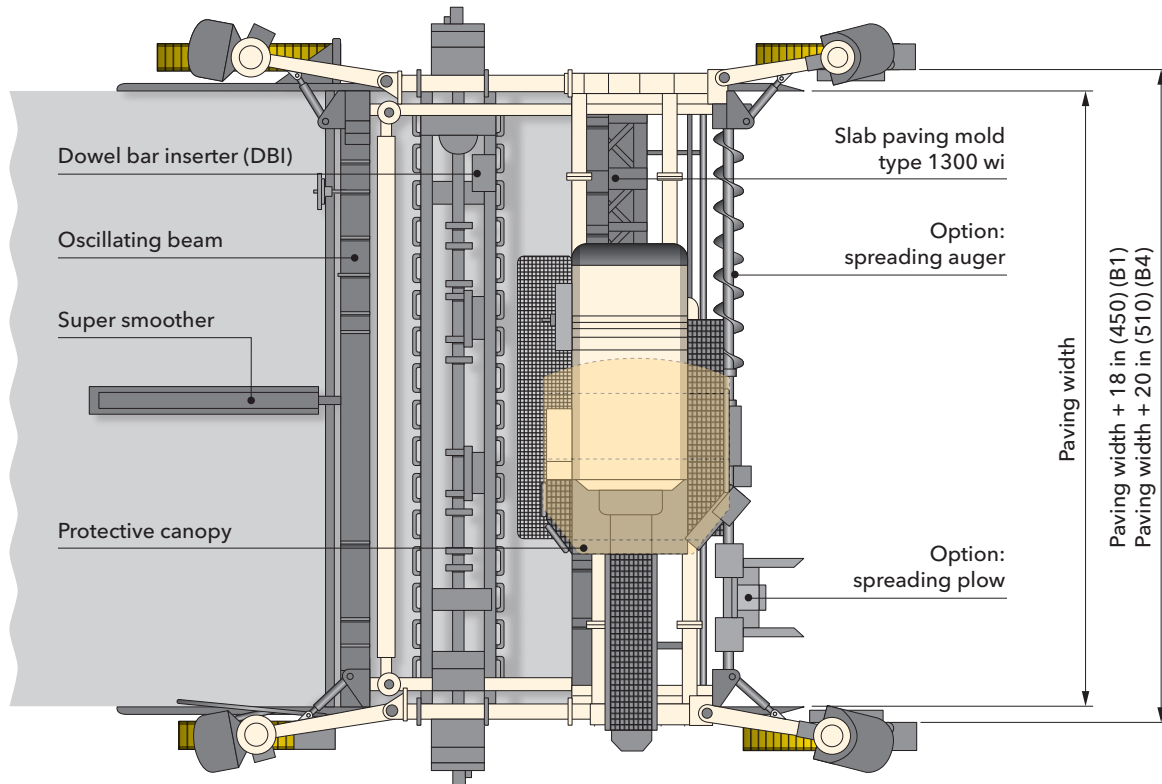

Side tie bar inserter not included in illustration

Dimensions in American standard and mm

\*<sup>2</sup> = Applies to standard longitudinal joint tie bar inserter (non-pivotable)

# Dimensions

## SP 94i

20  
21

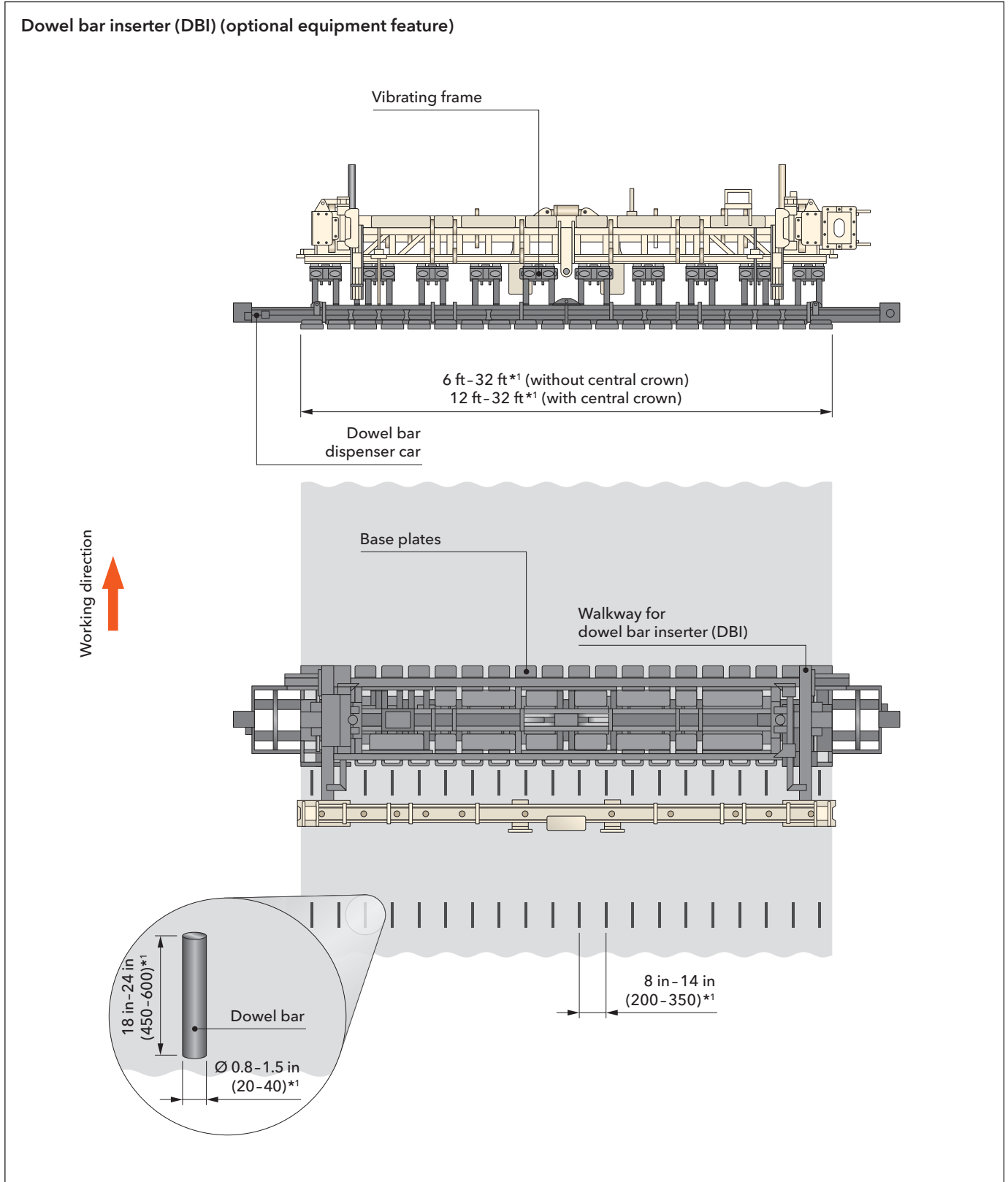

Dimensions in American standard and mm

\*<sup>1</sup> = Applicable for the range of dowel bar dimensions specified; for other dimensions, please consult factory. The dowel bar inserters will be customized in accordance with preselected customer requirements.



Transport situation: slipform paver SP 94i equipped with spreading auger or spreading plow, slab paving mold type 1300 wi, and super smoother

Transport situation: slipform paver SP 94i equipped with spreading auger or spreading plow, slab paving mold type 1300 wi, dowel bar inserter (DBI), oscillating beam, and super smoother

**Option A\*<sup>2</sup>:**

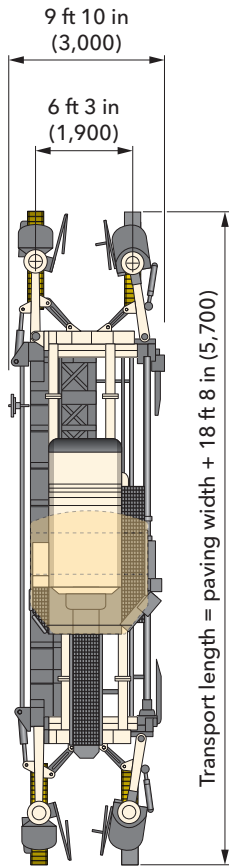

Transport height:  
10 ft 2 in (3,100)

- To be removed\*<sup>3</sup>:**
- Super smoother carriage
  - Linkage of hydraulic pivoting legs, front

**Option B\*<sup>2</sup>:**

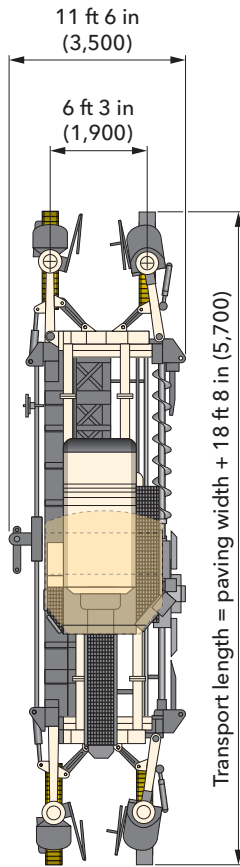

Transport height:  
10 ft 2 in (3,100)

- To be removed\*<sup>3</sup>:**
- Screed plate of super smoother

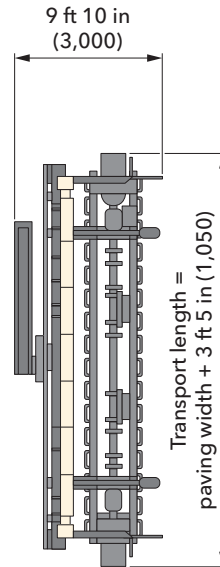

Transport height:  
8 ft 4 in (2,550)

- Transport unit comprising\*<sup>3</sup>:**
- Dowel bar inserter (DBI)
  - Oscillating beam
  - Super smoother

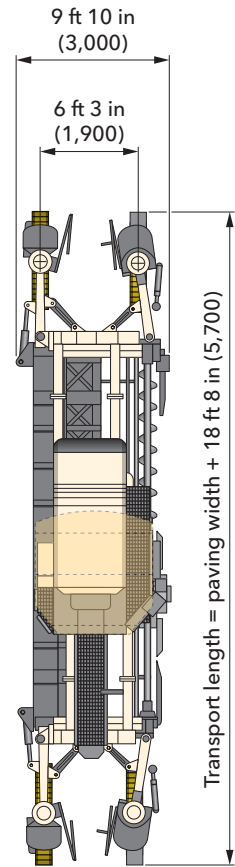

Transport height:  
10 ft 2 in (3,100)

- Transport unit comprising\*<sup>3</sup>:**
- Machine tractor
  - Slab paving mold
  - Concrete spreading unit
  - Removed: linkage of hydraulic pivoting legs, front

Dimensions in American standard and mm

\*<sup>2</sup> = Longitudinal joint tie bar inserter not included (additional transport unit)

\*<sup>3</sup> = Removal of additional components may be necessary depending on machine configuration

# Standard Equipment

## SP 94i

22  
23

Basic Machine	
Hydraulic system including an adequately sized hydraulic oil tank and a pump transfer gearbox with four output shafts and the pumps required for the machine's basic equipment package	■
Cooling system with temperature-controlled fan speed	■
Electrical system (24 V)	■
Fuel tank 132 gal (500 l)	■
Main Frame and Height Adjustment	
Heavy-duty steel frame, telescoping in stages by total 9 ft (2.75 m) on both sides, can be optionally extended by fixed extension pieces	■
The machine frame is pre-fitted with multiple mounting points for the modular addition of a variety of equipment features	■
Four hydraulic leveling cylinders with a stroke of 3 ft 3 in (1.00 m)	■
Frame elements for mechanical telescoping in increments to working widths of up to 20 ft 6 in (6.25 m)	□
Crawler Units and Chassis Linkage	
Four height-adjustable B4 track units, 14 in (350 mm) wide, including cylinder drives	□
Machine Control, Leveling, and Steering	
WI-CONTROL - high-quality control system ensuring perfect interaction between all machine features	■
Error messages are displayed on the machine's control screen	■
The existing CAN bus system can be expanded to customer specifications	■
ECO mode: performance-optimized engine management system for reduced diesel consumption and low noise emissions	■
Proportional electrohydraulic leveling and steering by means of a PLC system including four leveling sensors and two steering sensors	■
Sensor mounting brackets, adjustable in height and range	■
Vibration	
Hydraulic vibrator drive for max. 12 vibrators	□
Ten curved vibrators D66, hydraulically driven	□

- = Standard equipment
- = Standard equipment, can be replaced with optional equipment if desired
- = Optional equipment



Concrete Equipment for Slab Paving	
Paving mold series 1300 wi, without crown – basic width 12 ft	<input type="checkbox"/>
One-piece side header for mold series 1300 wi/1310 wi	<input type="checkbox"/>
Flat inserts for the outer edges of the mold series 1300 wi	<input type="checkbox"/>
Operator's Platform	
Ergonomically designed operator's platform providing a perfect view of the paving process	<input checked="" type="checkbox"/>
Three control panels with clear, language-independent labeling for ergonomic operation	<input checked="" type="checkbox"/>
Control panel 1 for machine setup according to site requirements	<input checked="" type="checkbox"/>
Control panel 2 with multifunctional control screen providing the operator with all relevant machine parameters and allowing settings to be made via a menu	<input checked="" type="checkbox"/>
The control panel can be adjusted to all directions of travel and paving configurations	<input checked="" type="checkbox"/>
Control panel 3 for controlling the concrete equipment	<input checked="" type="checkbox"/>
Two control panels can be stored in the engine compartment; the third control panel can be protected against vandalism and weather by means of a lockable cover	<input checked="" type="checkbox"/>
Automatic recognition of each machine configuration provides easy orientation for the machine operator	<input checked="" type="checkbox"/>
Miscellaneous	
Paving Plus package: pivot angle display, speed indicator, and fully digital Ackermann steering	<input checked="" type="checkbox"/>
Comprehensive toolkit in lockable toolbox	<input checked="" type="checkbox"/>
Comprehensive safety package with EMERGENCY STOP switches	<input checked="" type="checkbox"/>
Filling of the machine's hydraulic system with mineral hydraulic oil	<input checked="" type="checkbox"/>
Pre-fitting for installing the WITOS FleetView control unit	<input checked="" type="checkbox"/>
Standard painting in RAL 9001 (cream)	<input type="checkbox"/>
WITOS FleetView - professional telematics solution for machine operation and service optimization	<input type="checkbox"/>
Lighting system including four halogen working lights, 24 V	<input type="checkbox"/>

- = Standard equipment
- = Standard equipment, can be replaced with optional equipment if desired
- = Optional equipment

# Optional Equipment

## SP 94i

Main Frame and Height Adjustment	
Frame elements or mechanical telescoping in increments to working widths of up to 26 ft 3 in (8.00 m)	<input type="checkbox"/>
Frame elements for mechanical telescoping in increments to working widths of up to 32 ft (9.50 m)	<input type="checkbox"/>
Frame elements for continuous hydraulic telescoping to working widths of up to 20.5 ft (6.25 m), including extension elements	<input type="checkbox"/>
Frame elements for continuous hydraulic telescoping to working widths of up to 26 ft 3 in (8.00 m)	<input type="checkbox"/>
Frame elements for continuous hydraulic telescoping to working widths of up to 32 ft (3.66 m)	<input type="checkbox"/>
Crawler Units and Chassis Linkage	
Four height-adjustable B4 track units, 14 in (350 mm)wide, including hydraulic rotational drives	<input type="checkbox"/>
Machine Control, Leveling, and Steering	
Cross-slope sensor for machine	<input type="checkbox"/>
Automatic crown adjustment	<input type="checkbox"/>
Two slab tracers	<input type="checkbox"/>
Four slab tracers	<input type="checkbox"/>
Control console for manual track unit steering	<input type="checkbox"/>
Preliminary equipment for 3-D leveling with Leica Topcon or Trimble	<input type="checkbox"/>
Additional slope sensors for 3-D leveling	<input type="checkbox"/>
Concrete Spreading Equipment for Slab Paving	
Spreading auger without crown - basic width 12 ft	<input type="checkbox"/>
Split spreader auger with/without crown - basic width 12 ft	<input type="checkbox"/>
Spreading plow - basic width 12 ft	<input type="checkbox"/>
Spreading auger - extension element 1.00 ft, right-hand pitch	<input type="checkbox"/>
Spreading auger - extension element 1.50 ft, right-hand pitch	<input type="checkbox"/>
Spreading auger - extension element 2.00 ft, right-hand pitch	<input type="checkbox"/>
Spreading auger - extension element 4.00 ft, right-hand pitch	<input type="checkbox"/>
Spreading auger - extension element 1.00 ft, left-hand pitch	<input type="checkbox"/>
Spreading auger - extension element 1.50 ft, left-hand pitch	<input type="checkbox"/>
Spreading auger - extension element 2.00 ft, left-hand pitch	<input type="checkbox"/>
Spreading auger - extension element 4.00 ft, left-hand pitch	<input type="checkbox"/>
Spreading plow - extension element 1.00 ft	<input type="checkbox"/>
Spreading plow - extension element 1.50 ft	<input type="checkbox"/>
Spreading plow - extension element 2.00 ft	<input type="checkbox"/>
Spreading plow - extension element 4.00 ft	<input type="checkbox"/>

- = Standard equipment
- = Standard equipment, can be replaced with optional equipment if desired
- = Optional equipment



Vibration	
Hydraulic vibrator drive for max. 18 vibrators	<input type="checkbox"/>
Hydraulic vibrator drive for max. 24 vibrators	<input type="checkbox"/>
Electric vibrator drive with 60 kVA generator for max. 12 vibrators	<input type="checkbox"/>
Electric vibrator drive with 60 kVA generator for max. 20 vibrators	<input type="checkbox"/>
Electric vibrator drive with 60 kVA generator for max. 28 vibrators	<input type="checkbox"/>
Ten curved vibrators D76, electrically driven	<input type="checkbox"/>
Tamper bar without crown - basic width 12 ft	<input type="checkbox"/>
Tamper bar with/without crown - basic width 12 ft	<input type="checkbox"/>
Curved vibrator D66, hydraulically driven	<input type="checkbox"/>
Curved vibrator D76, electrically driven	<input type="checkbox"/>
Tamper bar - extension element 1.00 ft	<input type="checkbox"/>
Tamper bar - extension element 1.50 ft	<input type="checkbox"/>
Tamper bar - extension element 2.00 ft	<input type="checkbox"/>
Tamper bar - extension element 4.00 ft	<input type="checkbox"/>
Concrete Equipment for Slab Paving	
Metering gate for molds without crown - basic width 12 ft	<input type="checkbox"/>
Split metering gate for molds with/without crown - basic width 12 ft	<input type="checkbox"/>
Automatic metering gate control for concrete paving mold	<input type="checkbox"/>
Paving mold series 1300 wi, with crown - basic width 12 ft - including hydraulic middle suspension	<input type="checkbox"/>
Two-piece side header for start of shift with mold series 1300 wi/1310 wi	<input type="checkbox"/>
Paving mold series 1300 wi - extension element 1.00 ft	<input type="checkbox"/>
Paving mold series 1300 wi - extension element 1.50 ft	<input type="checkbox"/>
Paving mold series 1300 wi - extension element 2.00 ft	<input type="checkbox"/>
Paving mold series 1300 wi - extension element 4.00 ft	<input type="checkbox"/>
ESC "Edge Slump Control" inserts for the outer edges of the mold series 1300 wi	
Profile insert for series 1300 wi/1310 wi	<input type="checkbox"/>
Automatic dowel bar inserter (DBI) for use without crown - basic width 12 ft - mechanically telescoping	<input type="checkbox"/>
Automatic dowel bar inserter (DBI) for use with crown - basic width 14 ft - mechanically telescoping	<input type="checkbox"/>
Base group for dowel bar inserter (DBI) for paving width up to 12 ft	<input type="checkbox"/>

- = Standard equipment
- = Standard equipment, can be replaced with optional equipment if desired
- = Optional equipment

# Optional Equipment

## SP 94i

Concrete Equipment for Slab Paving	
Base group for dowel bar inserter (DBI) for paving width up to 14 ft	<input type="checkbox"/>
Base group for dowel bar inserter (DBI) for paving width up to 18 ft	<input type="checkbox"/>
Base group for dowel bar inserter (DBI) for paving width up to 22 ft	<input type="checkbox"/>
Base group for dowel bar inserter (DBI) for paving width up to 26 ft	<input type="checkbox"/>
Base group for dowel bar inserter (DBI) for paving width up to 30 ft*	<input type="checkbox"/>
Frame extension + electrical control for dowel bar inserter (DBI)	<input type="checkbox"/>
Dowel bar inserter (DBI) - extension element 1.00 ft	<input type="checkbox"/>
Dowel bar inserter (DBI) - extension element 1.50 ft	<input type="checkbox"/>
Dowel bar inserter (DBI) - extension element 2.00 ft	<input type="checkbox"/>
Dowel bar inserter (DBI) - extension element 4.00 ft	<input type="checkbox"/>
Load brackets as modification aid for altering the width of the dowel bar inserter (DBI)	<input type="checkbox"/>
DBI self-loading device including diesel-powered hydraulic unit	<input type="checkbox"/>
Oscillating beam without crown - basic width 12 ft	<input type="checkbox"/>
Oscillating beam with /without crown - basic width 12 ft	<input type="checkbox"/>
Oscillating beam - extension element 1.00 ft	<input type="checkbox"/>
Oscillating beam - extension element 1.50 ft	<input type="checkbox"/>
Oscillating beam - extension element 2.00 ft	<input type="checkbox"/>
Oscillating beam - extension element 4.00 ft	<input type="checkbox"/>
Super smoother - basic width 12 ft	<input type="checkbox"/>
Super smoother - extension element 1.00 ft	<input type="checkbox"/>
Super smoother - extension element 1.50 ft	<input type="checkbox"/>
Super smoother - extension element 2.00 ft	<input type="checkbox"/>
Super smoother - extension element 4.00 ft	<input type="checkbox"/>
One side tie bar drive-in device for straight tie bars, max. $\varnothing$ $\frac{3}{4}$ " , length 2.50 ft	<input type="checkbox"/>
Two side tie bar drive-in devices for straight tie bars, max. $\varnothing$ $\frac{3}{4}$ " , length 2.50 ft	<input type="checkbox"/>
Transport frame for oscillating beam and super smoother as transport unit	<input type="checkbox"/>

- = Standard equipment
- = Standard equipment, can be replaced with optional equipment if desired
- = Optional equipment

\* = Please consult factory for special paving widths

Operator's Platform	
Weather canopy for operator's platform, hydraulically telescoping in height	<input type="checkbox"/>
Weather canopy for operator's platform, hydraulically telescoping in height, with LED lighting	<input type="checkbox"/>
Extension of walkway allowing the operator to pass from one side of the machine to the other	<input type="checkbox"/>
Miscellaneous	
Painting in one special color (RAL)	<input type="checkbox"/>
Painting in two special colors (RAL)	<input type="checkbox"/>
Painting in maximum two special colors with the lower part of the machine painted in special color (RAL)	<input type="checkbox"/>
Model without WITOS FleetView	<input type="checkbox"/>
High-performance lighting system including eight LED working lights, 24 V	<input type="checkbox"/>
Hydraulic high-pressure water cleaning system with 145 gal (550 l) plastic tank	<input type="checkbox"/>
Two hydraulic high-pressure water cleaning systems with two 145 gal (550 l) plastic tanks	<input type="checkbox"/>
Additional electrical water pump, 24 V, with 32 ft 10 in (10.00 m) hose and spray gun with handle	<input type="checkbox"/>
Additional plastic water tank, 145 gal (550 l)	<input type="checkbox"/>
Self-leveling feature for transport mode	<input type="checkbox"/>
Rotating beacon, halogen 24 V, with magnetic base	<input type="checkbox"/>
Two flashing beacons, 24 V, with magnetic base	<input type="checkbox"/>
Two LED floodlights including power generator (230 V)	<input type="checkbox"/>
Two LED floodlights including power generator (110 V)	<input type="checkbox"/>
Stringline tensioning system, complete with 3,280 ft (1,000 m) steel wire rope	<input type="checkbox"/>
Additional tensioning winch for stringline tensioning system	<input type="checkbox"/>
Stringline tensioning system, complete with 4 x 984 ft (4 x 300 m) nylon rope	<input type="checkbox"/>
Machine commissioning (day rate)	<input type="checkbox"/>
Export packaging	<input type="checkbox"/>

- = Standard equipment
- = Standard equipment, can be replaced with optional equipment if desired
- = Optional equipment





WIRTGEN AMERICA Inc.  
6030 Dana Way · Antioch, TN 37013, USA  
Phone: (615) 501-0600 · Fax: (615) 501-0691  
Internet: [www.wirtgen-group.com/america](http://www.wirtgen-group.com/america)

