

Efficient removal and granulation of road surfaces.

The World of Wirtgen Cold Milling Machines





State-of-the-art milling technology meets all of the requirements for cost-effective and environmentally friendly road rehabilitation. Our vision to use innovative milling technology to quickly and effectively remove road surfaces marked the beginning of the era of cold milling technology. Since then, WIRTGEN has been regarded as the global market leader in this highly complex field. Fascinated by the unimagined possibilities of the process, we are the driving force behind continuous advancement, ensuring that our innovative solutions will continue to revitalize the road network for decades to come.

Cutting-edge technology

for better roads.



Keeping Traffic Moving with Cold Milling Machines

04
05

AN EFFICIENT PROCESS

Cold milling machines are used to remove asphalt and concrete surfaces quickly and efficiently. In doing so, they create a level foundation with the specified width and depth that is required for paving new surface layers of uniform thickness. This is important, because the condition of the milled surface has a major impact on the quality of the new surface layers, their performance characteristics, and on the cost-effective completion of further construction work. When pavements are milled in layers, the milled material can be separated and selectively recovered according to mix type.

1 | *Milled material is generally reused as a valuable recyclable construction material.*

In cold milling, a distinction is made between maintenance (minor construction measures to preserve the structural integrity of the surface), repair (major construction measures to preserve the structural integrity of the surface and improve its properties), and rehabilitation (complete restoration).

As the market leader in the field of cold milling machines, WIRTGEN has been the key driver of numerous innovations and pioneering technologies. Today WIRTGEN offers by far the most comprehensive product range in the industry.

1 |



2 | Both the entire thickness of the road surface and individual, thin layers can be removed.

3 | The cold milling method is used in a wide variety of applications worldwide and is unmatched from both an economic and environmental point of view.



From Service Provider to Global Market Leader

06
07

1971

The first prototype of a hot milling machine successfully removes damaged asphalt surfaces.



1979

The first cold milling machine, the 3800 C, is a rear loader with hydraulic milling drum drive.



1984

The first front loader, the 2000 VC, permanently changes job site logistics.



1988

The DC series with working depths up to 300 mm extends the range of applications considerably.



2001

The FCS quick-change system for milling drums increases the flexibility of the machines.



2005

WIRTGEN LEVEL PRO leveling technology makes cold milling extremely precise.



2010

The new generation of large milling machines - the W 200 to W 250 - sets new standards in milling performance.



2015

The W 50 Ri and W 100 CFI embody a new, highly effective method of operating small milling machines.



1980

The 500 C, the first half-meter cold milling machine, mills to a depth of 100 mm.



1992

The first bolted toolholder system increases cold milling machines' operational availability.



2009

The VCS extraction system reduces dust emissions during operation.



2019

The new F series of large milling machines, with MILL ASSIST and the Performance Tracker, set new standards of cost-effectiveness.



INNOVATIVE MILESTONES

Today's technologically advanced cold milling machines can load a 30-ton truck with asphalt granulate within a few minutes. The road to this point was a long one, however - WIRTGEN has always been instrumental in driving progress in this field.

WIRTGEN built the first of a total of 100 hot milling machines for its own service fleet in 1971. The idea to use the round shank bits used in mining with carbide tips made the technological transition from hot milling to cold milling possible in 1979.

From the first building block - the development of cold milling technology for road construction - to the present day, WIRTGEN has reached numerous innovative milestones along the road to this technology's success. Today, the name WIRTGEN is synonymous with high-performance cold milling technology throughout the world.

Features of a Rear-Loading Small Milling Machine

08
09

HEIGHT-ADJUSTABLE DISCHARGE
CONVEYOR THAT CAN SWING IN
BOTH DIRECTIONS



FOR MILLING FLUSH
TO THE EDGE

MILLING DRUMS OF DIFFE-
RENT WIDTHS WITH VARIA-
BLE TOOL SPACINGS

LOADING THE MILLED MATERIAL TO THE REAR

Small milling machines offer high mobility and flexibility. They are used for machining small surfaces and for precise milling in confined spaces and are equipped with a wheeled chassis. The milling drum is installed at the back of the machine.

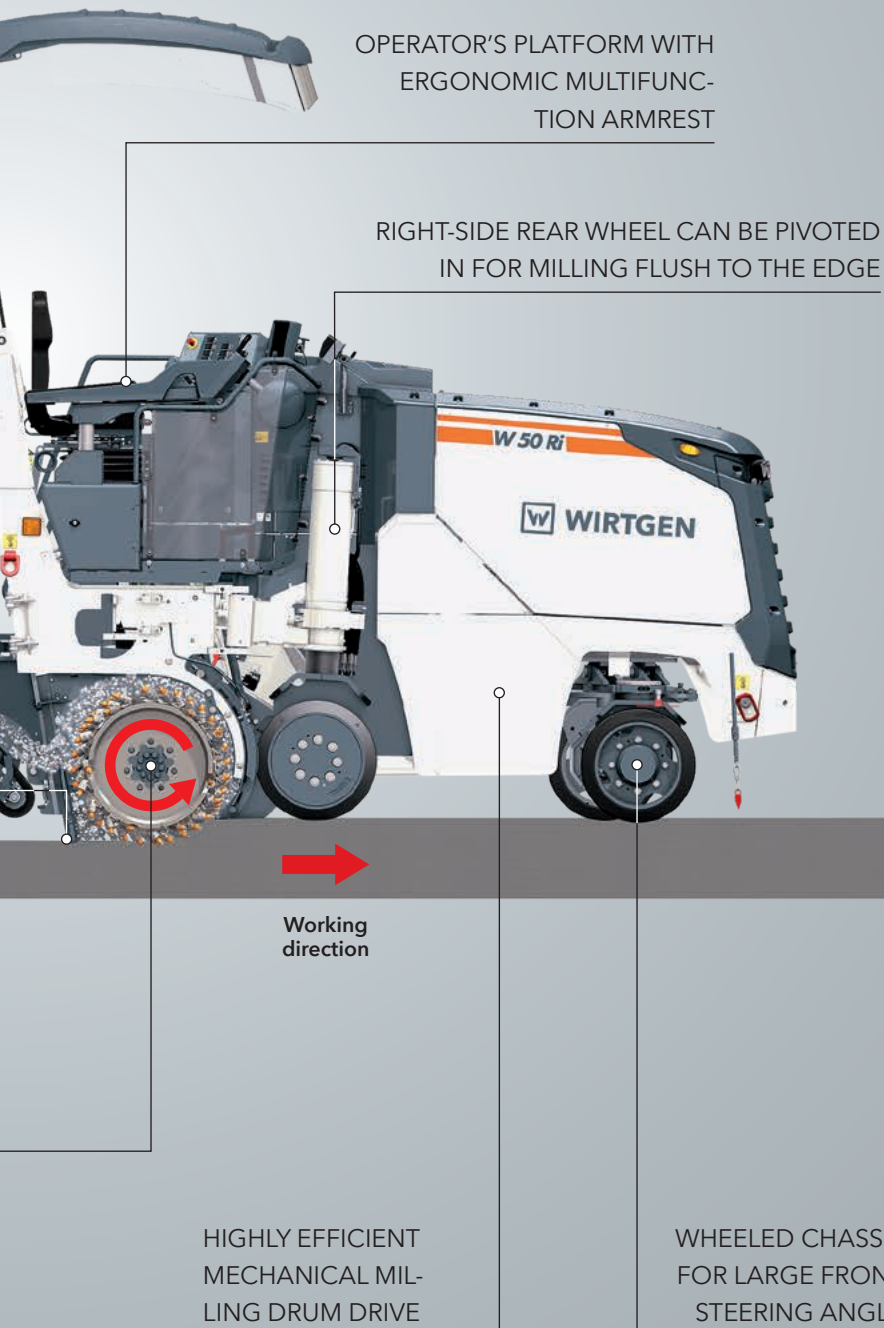

Features of a Front-Loading Compact Milling Machine

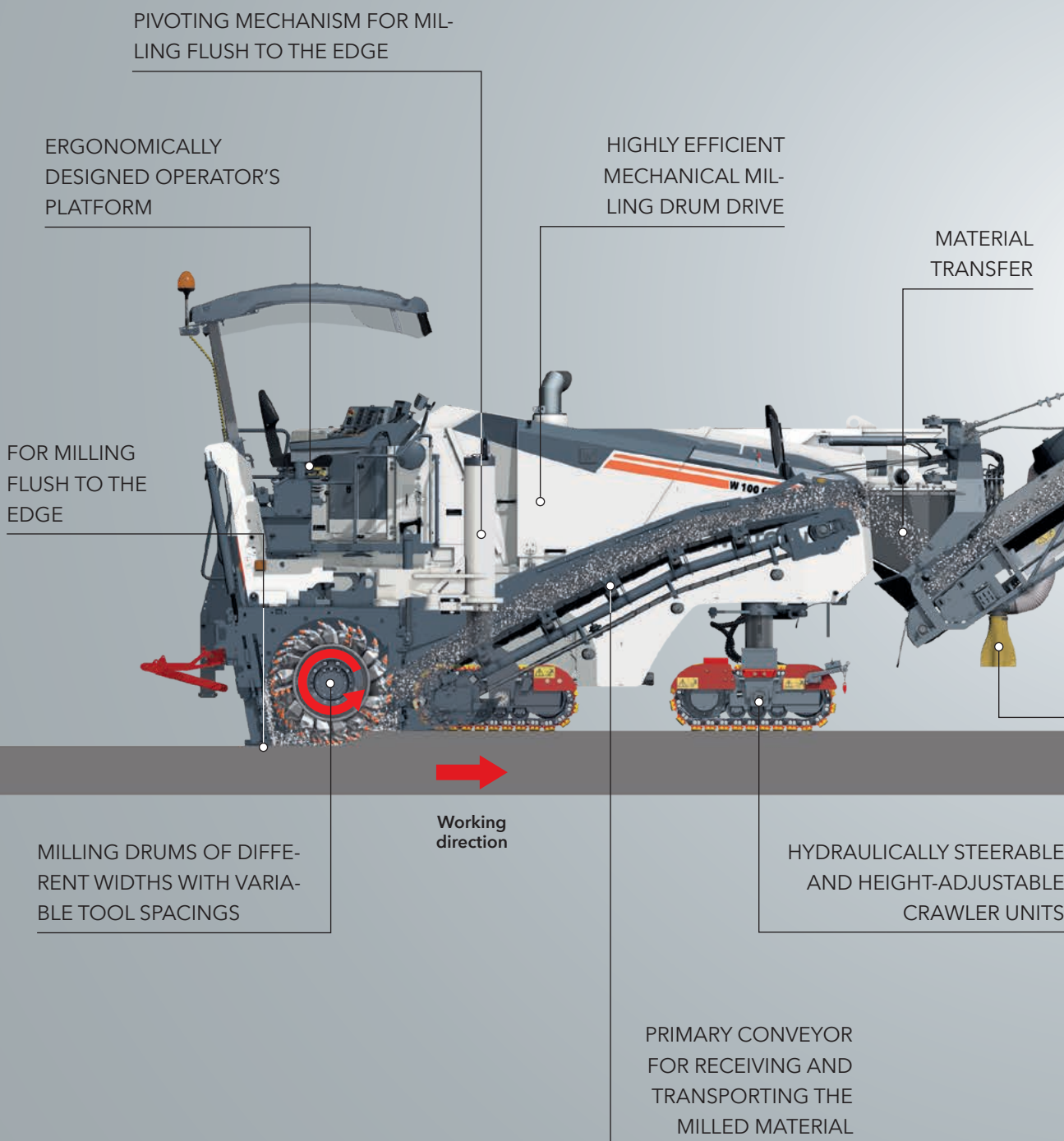

LOADING THE MILLED MATERIAL TO THE FRONT

The highly flexible compact milling machines combine the advantages of the small and large milling machine classes. The lightweight, maneuverable front loaders can be used in confined spaces and, thanks to their high level of performance, are suitable for a wide range of applications. They are equipped with a wheeled chassis or crawler units.



HEIGHT-ADJUSTABLE
DISCHARGE CONVEYOR
THAT CAN SWING IN
BOTH DIRECTIONS

VACUUM CUTTING SYSTEM
FOR THE EXTRACTION OF
FINE MATERIAL PARTICLES

Features of a Front-Loading Large Milling Machine

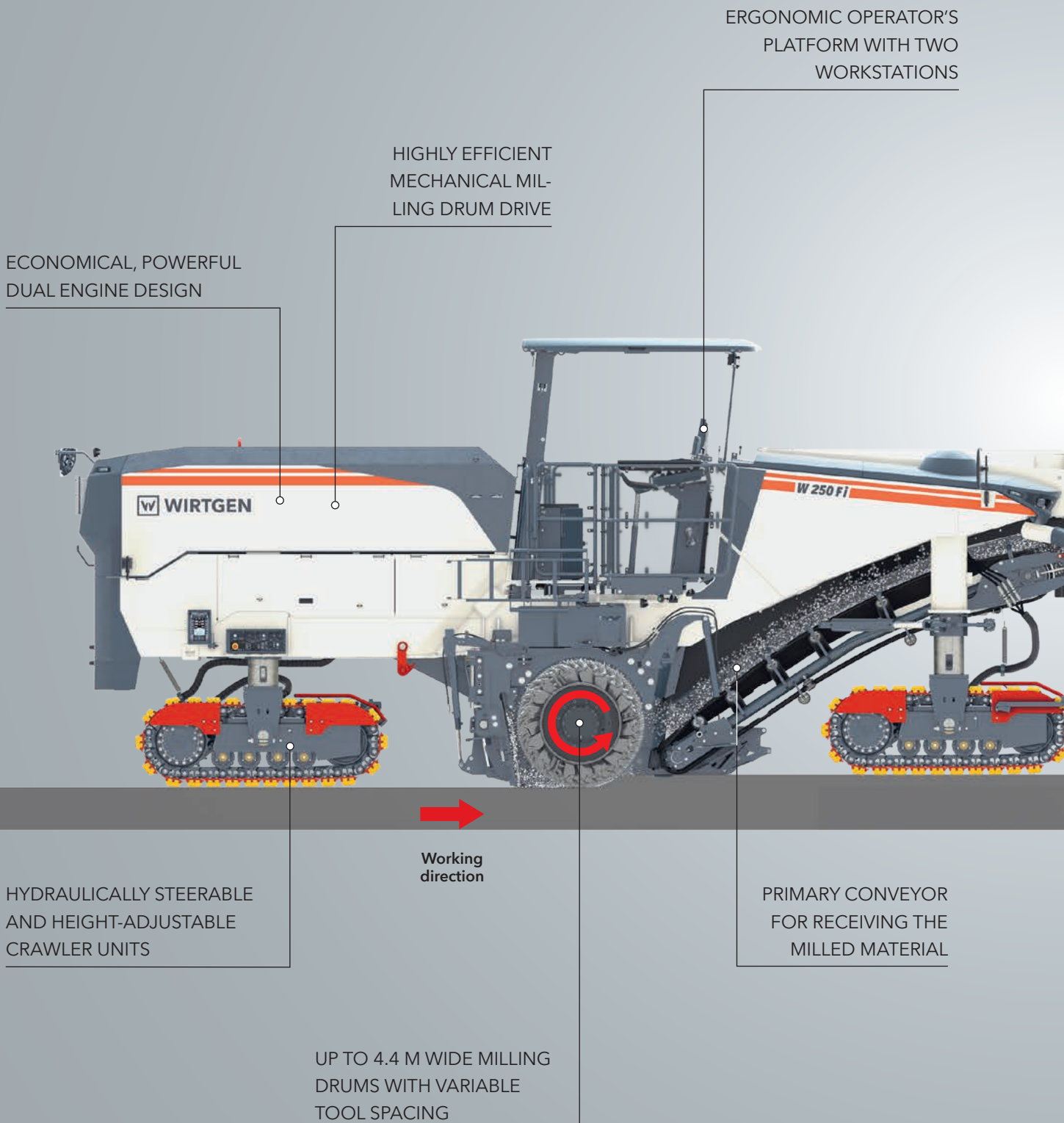

LOADING THE MILLED MATERIAL TO THE FRONT

Due to their high milling performance, large milling machines are particularly suitable for repair work on large areas. The front loaders are equipped with four hydraulically steerable and height-adjustable crawler units, with the milling drum positioned in the center beneath the machine. The proximity of the drum to the machine's center of gravity significantly increases milling performance.

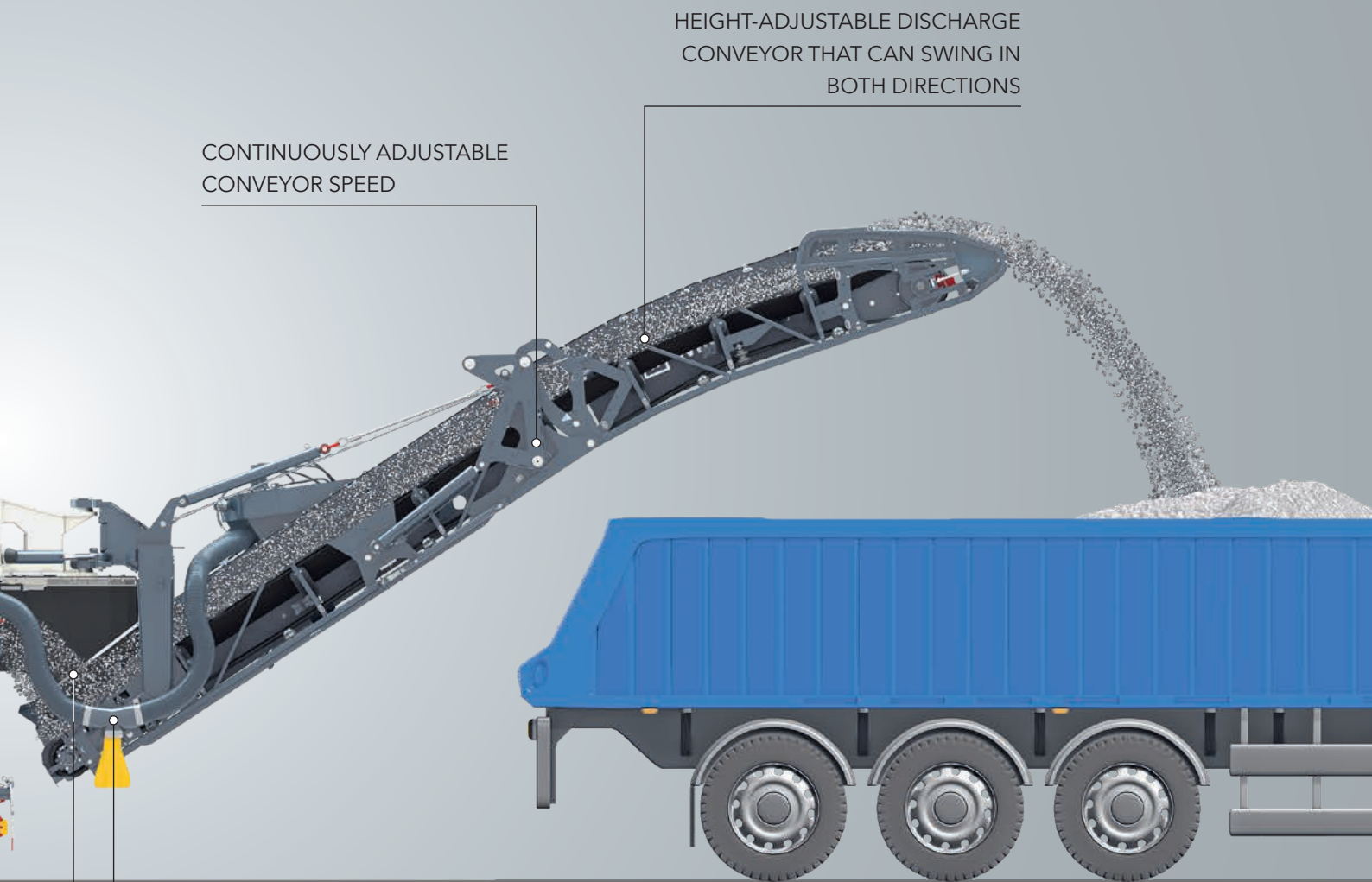

HEIGHT-ADJUSTABLE DISCHARGE
CONVEYOR THAT CAN SWING IN
BOTH DIRECTIONS

CONTINUOUSLY ADJUSTABLE
CONVEYOR SPEED

VACUUM CUTTING SYSTEM
FOR THE EXTRACTION OF
FINE MATERIAL PARTICLES

MATERIAL TRANSFER

Wirtgen Key Technology: Cutting Technology

14
15

HIGH-TECH IN ASPHALT

In order to efficiently remove pavement with precision, it is essential that the milling drum, pick holder, and round shaft pick work together perfectly. WIRTGEN is the market leader in cutting technology and offers customers high-performance cutting systems whose components are designed to be fully compatible. In addition, WIRTGEN continuously makes advancements to these cutting technology components, incorporating its practical experience and feedback from customers into the process.

The heavy-duty picks offer maximum wear resistance. This increases milling performance and extends the intervals between tool changes.

The rugged **HT22** toolholder system minimizes downtimes and increases the service life of the entire milling drum.

The **HT22 PLUS** toolholder upper part features innovative centering marks (Fig. 3) on the tool contact surface. In combination with the X² generation of round shaft picks, this reduces toolholder wear by up to 25% and also optimizes the rotation behavior of the picks. The upper part offers considerable benefits such as higher milled surface quality and longer intervals between changes.

1 | WIRTGEN milling drum units are the perfect combination of expertise acquired over more than 50 years and groundbreaking technologies.





2 | The unique slot profile with innovative centering function on the wear plate increases the service life of the generation X² picks by up to 25%.

3 | Detailed view of the generation X² HT22 Plus round shaft pick.

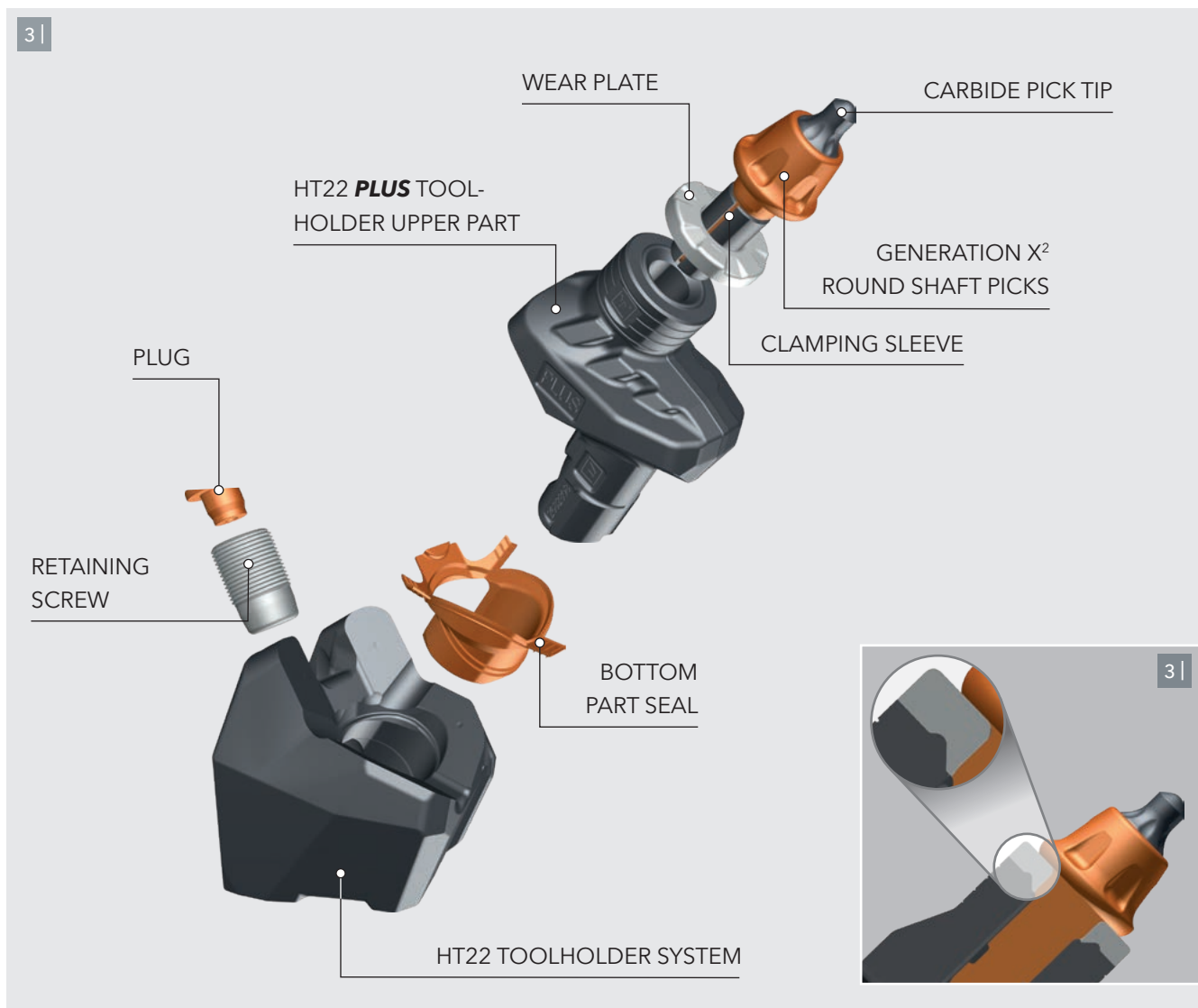

Wirtgen Key Technology: Machine Control

16
17

PRODUCTIVE INTELLIGENCE

State-of-the-art cold milling machines are efficient construction machines whose key success factor is their high milling performance. Intelligent, computer-assisted automatic functions assist the operator so that they need to intervene in the milling process as little as possible. With WIRTGEN high-performance cold milling machines, for example, the operator is supported by the innovative proprietary **MILL ASSIST** machine control system.

In automatic mode, **MILL ASSIST** always selects the operating strategy with the best balance between performance and costs. In doing so, the process optimization automatically adjusts the speed of the diesel engine and milling drum, the travel drive, the water system, and the machine's advance speed. This significantly reduces the operator's workload while improving machine performance and considerably reducing diesel consumption, CO₂ emissions, and noise.

1 | Intelligent computer control systems support the machine operator during their daily operations.





2 | The milling machine's intelligently designed visibility concept makes the operator's work much easier and results in precise milling results.

3 | The innovative MILL ASSIST machine control system helps the machine operator optimize the results of the milling process.

2 |

3 |



PRE-SELECTION OF AN OPERATING STRATEGY IN AUTOMATIC MODE

DUAL SHIFT POWERSHIFT TRANSMISSION

ENGINE SPEED

CONVEYOR SPEED

MACHINE ADVANCE SPEED

VARIABLE WATER INJECTION SYSTEM

MILLING DRUM SPEED

CLEAR PRE-SELECTION OF CONSTANT MILLING PATTERN QUALITY

MILL ASSIST is only available in F series machines

Wirtgen Key Technology: Leveling

18
19

SYSTEMS DEVELOPED COMPLETELY IN-HOUSE

When milling, it's important to remove the layers of asphalt at the specified depth.

WIRTGEN's intuitive **LEVEL PRO / LEVEL PRO PLUS / LEVEL PRO ACTIVE**

leveling technology can be relied on to precisely maintain the specified milling depth. The high-tech leveling system developed in-house at WIRTGEN with software specially programmed for cold milling machines is fully integrated into the control system of the entire machine. **LEVEL PRO / LEVEL PRO PLUS / LEVEL PRO ACTIVE** constantly compares the current milling depth with the preset target value.

If the system detects deviations, they are dynamically and proportionally corrected. The actual milling depth is determined via optical or mechanical sensors that continuously scan a reference surface.

The WIRTGEN leveling system can not only be operated with a wide variety of sensors, but can also be extended as required - for example with the multiplex system, laser leveling, or thanks to a preinstalled interface, with 3D leveling.

1 | WIRTGEN's leveling technology adjusts height, depth, and pitch for extremely accurate results and reduces the operator's workload.



2 | LEVEL PRO/
LEVEL PRO PLUS/
LEVEL PRO ACTIVE
stands for perfect
leveling quality
at high working
speeds.

3 | Scanning in front
of the milling drum.

4 | Telescoping
leveling boom on
the right or left.

5 | Multiplex system
with up to four
ultrasonic sensors.

6 | 3D leveling/
laser leveling.

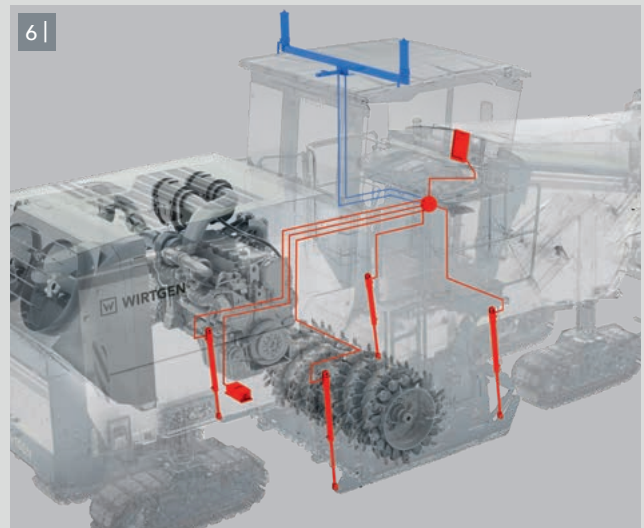
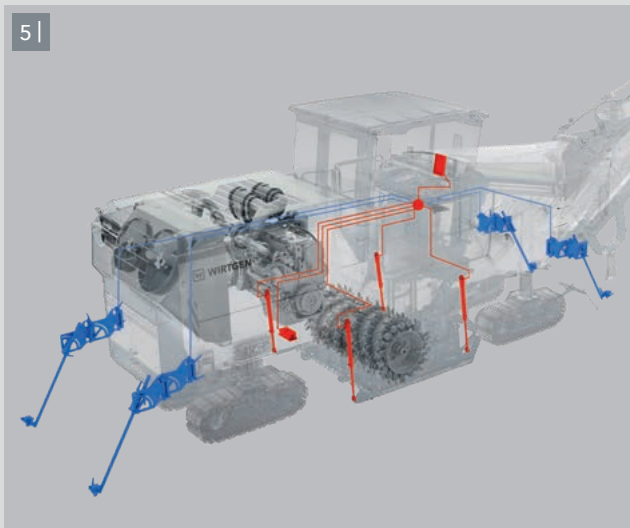
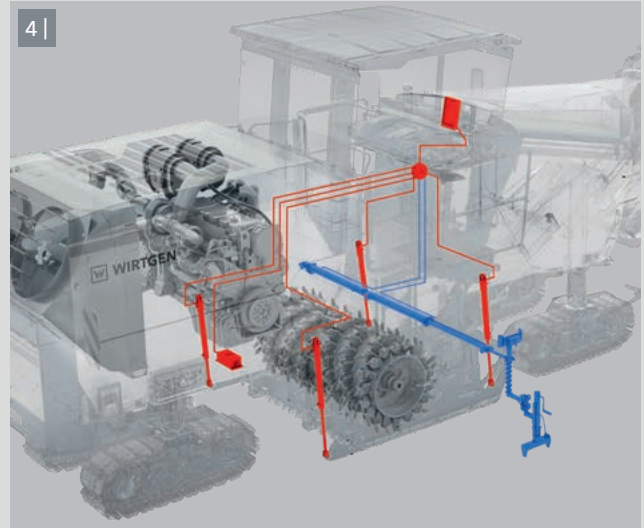
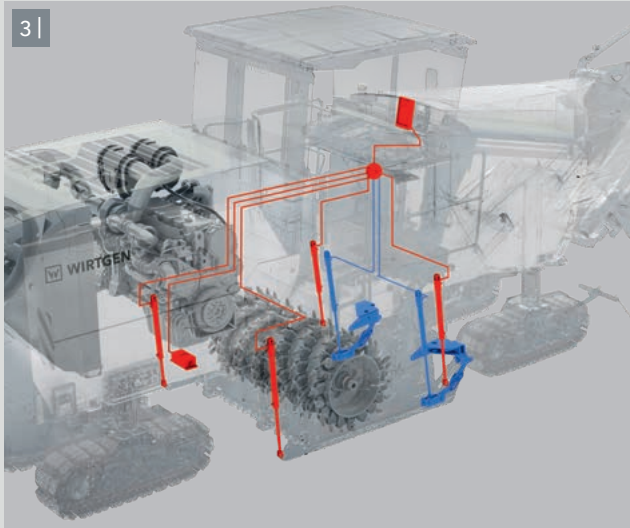

The largest range of

machines worldwide.



THE PERFECT SOLUTION FOR EVERY APPLICATION

WIRTGEN offers by far the widest range of cold milling machines worldwide. The standard range already covers the entire milling width spectrum from 14 mm to 4.4 m. The selection of machines extends from the extremely compact W 35 Ri cold milling machine - which is also suitable for indoor applications - to the W 250 Fi, which is capable of completing major projects on highway or airport job sites in record time.

Our delivery range leaves nothing to be desired. It offers a customized, state-of-the-art solution for every customer-specific application. From additional milling drums to the optional VCS dust extraction system to the hydraulically adjustable and rotating operator's cabin (OCS) - to name just a few options - customers can generally select from a large number of equipment options for their cold milling machines to ensure that they always achieve maximum performance, even under complex job site conditions.



W 35 Ri



W 35 X Ri



W 50 R



W 50 Ri



W 50 H



W 55 H



W 60 R



W 60 Ri



W 100 R



W 100 Ri



W 120 R



W 120 Ri

SMALL MILLING MACHINES

Milling width up to 1,300 mm

Milling depth to 300 mm



W 100 H



W 130 H



W 100 CF



W 100 CFi



W 100 X Fi



W 120 CF



W 120 CFi



W 120 X Fi



W 120 XTi



W 130 CF



W 130 CFi



W 130 X Fi



W 150 CF



W 150 CFi

COMPACT MILLING MACHINES

Milling width up to 1,800 mm

Milling depth to 330 mm



W 150 X Fi



W 195



W 200 F



W 200 Fi



W 200 Hi



W 205



W 207 Fi



W 210 Fi



W 210 XP



W 215



W 220 Fi



W 250 Fi

LARGE MILLING MACHINES

Milling width up to 4,400 mm

Milling depth to 350 mm

A Wide Range of Applications: Small Milling Machines

22
23

MILLING IN EXTREMELY TIGHT SPACES

WIRTGEN's small milling machines stand out particularly for their outstanding versatility and flexibility. Thanks to their maneuverability, they are the ideal solution for milling jobs where space is at a premium. Their compact dimensions also make it easier to transport them.

The machines' minimal milling radius is ideal for milling around road installations and obstacles as well as around tight curves. In addition, special milling drums and ancillary equipment make it easy to mill rumble strips, slots, and tie-ins.

Small milling machines are also the best choice for the rehabilitation of industrial spaces and production hall floors due to their small size. The same applies to patching specific sections of road or adding and removing road surface markings.



1 | *The optional road sweeper can be used to sweep the area to be milled ahead for a better view.*

2 | *The Rumble Strip is used to mill in rumble strips along the edge of the road, which cause vibrations and tire noise when driving over them.*



3 | Milling a sidewalk.

4 | Milling operation in buildings with low ceiling heights and on surfaces with limited bearing capacity.

5 | Removing road surface markings.

6 | Exact exposure of road installations without requiring any additional work.

7 | Milling tie-ins in a residential area.



A Wide Range of Applications: Compact Milling Machines

24
25

MAXIMUM FLEXIBILITY

Compact milling machines from WIRTGEN combine the benefits of small and large milling machines and therefore offer tremendous flexibility. The machines, which are operated as front loaders, are particularly maneuverable on the one hand, but also offer a high level of performance on the other.

As a result, the compact class is suitable for milling jobs in tight spaces, for example, but also for removing entire road surfaces. Original WIRTGEN fine milling drums can be used to produce specific surface structures.

Compact milling machines can also be used for spot road repairs and the removal of road pavements in layers, as well as for smoothing out irregularities in the surface layer.

11



2 |



1 | The high-performance W 150 CFI is also suitable for larger milling jobs.

2 | To install fiber-optic cables, deep and narrow slots are milled into the asphalt with the deep milling unit.

3 |



3 | Steep gradient milling with the W 100 CFI.

4 |



4 | Removal of entire road pavements.

5 |



5 | Their tremendous maneuverability also makes compact milling machines suitable for milling parking lots.

6 |



6 | Performing spot road repairs with the W 130 CF in India.

A Wide Range of Applications: Large Milling Machines

26
27

FOR HIGH-PERFORMANCE MILLING OPERATIONS

WIRTGEN's most powerful class of milling machines is particularly suitable for the rehabilitation of large areas. Their impressive milling performance means that large milling machines can complete construction projects much faster, thereby minimizing traffic disruptions. Front loading ensures that the milled material is optimally loaded, and keeps the milling process flowing by continuously filling the trucks on the fly. In addition, this allows the trucks to move in and out smoothly in the direction of traffic.

Large milling machines' countless applications include the removal of road pavements in layers or the complete removal of road surfaces at milling depths of up to 35 cm.

Special milling drums can also be used to produce specific surface structures (fine milling) and improve grip. Large milling machines are also the first choice for smoothing out irregularities in the surface layer.



1 | The 3.8 m wide milling drum unit is perfect for the wide roads found in the United States.



2 | Our large milling machines are also used in tight and congested urban areas.



3 | The high-performance large milling machines are perfect for milling rural roads and highways.

4 | Tunnel milling in a confined space.

5 | High-performance milling using three large milling machines at an airport in Finland.

6 | High-precision milling over the entire surface of a cinder sports field.

7 | Concrete milling with the W 250 CFi.



The Worldwide Leader in Milling

ONE-OF-A-KIND PRODUCTS

- > Thanks to our decades of experience in the cold milling business, our machines are the most innovative on the market.
- > Cold milling machines from WIRTGEN are renowned for their consistently high performance, excellent quality, and maximum reliability.

A CLOSE RELATIONSHIP WITH CUSTOMERS

- > Your opinion is important to us, which is why our sales team - with its excellent knowledge of our products - engages in a dialog with every customer and always puts your needs first.
- > With its comprehensive technical expertise, our service team ensures that your WIRTGEN cold milling machines will have a long service life - we remain your reliable partner long after the sale.



As the global market leader in road construction, we have a responsibility to the environment which we take extremely seriously. For example, the selectively milled material is completely reused as a valuable recyclable construction material. In addition, we constantly strive to reduce machine emissions through groundbreaking advancements and environmentally friendly engines.

WE at WIRTGEN

30
31



As the global market leader, here at WIRTGEN we strive to meet our own high standards each and every day. This is why we are particularly proud of the fact that all of our machines are fully developed and manufactured in-house. From the idea to the design and production through to sales and service, our products are supported exclusively by extremely well-trained WIRTGEN employees.

In the process, our customers' opinions and interests play a particularly valuable role. This is because in addition to providing excellent after-sales service after the purchase of a machine, receiving feedback from customers - which we incorporate into the development of new products - is extremely important to us.





WIRTGEN GmbH
Reinhard-Wirtgen-Str. 2 · 53578 Windhagen · Germany
Phone: +49-26-45-131-0 · Fax: +49-26-45-131-392
Internet: www.wirtgen.de · E-mail: info@wirtgen.de

