

Technical information

SUPER 2100-5(i)



Tracked paver SUPER 2100-5(i)
Highway Class

TECHNICAL HIGHLIGHTS

- > Maximum pave width 14 m
- > Maximum laydown rate 1,100 t/h
- > Transport width 2.55 m
- > Engine output: 187 kW at 2,000 rpm

SUPER 2100-5(i) - The new generation

With the SUPER 2100-5(i) tracked paver, VÖGELE is taking two steps into the future at once: new operator ergonomics, more automated processes and faster set-up times, together with reduced noise and exhaust emissions.

The sum of further developments and new features make the SUPER 2100-5(i) a paver to equip our customers perfectly for the future. In addition to its technical features, the paver is also forward-looking in terms of sustainability - thanks to its economical consumption and low emissions.



TECHNICAL DATA	SUPER 2100-5i	SUPER 2100-5
Power unit		
	for EU and EFTA countries / USA / Canada / Japan / India / South Korea / Turkey	for all other countries
Engine	liquid-cooled 6-cylinder diesel engine	
> Version	John Deere	
> Manufacturer	John Deere	
> Type	6.8L PVS	6.8L PVN
Output		
> Nominal	187 kW at 2,000 U/min	
> ECO mode	178 kW at 1,700 U/min	
Emissions information		
> Exhaust emissions standards	European exhaust emissions standard EU Stage 5, US standard EPA Tier 4f, India CEV 5, South Korea KMOE 5	R96 Stage IIIa, Brazil MAR1
> Exhaust gas after-treatment	DOC, DPF, SCR	Exhaust silencer
> Guaranteed sound power level	L _{WA} = 108 dB(A) (2000/14/EG, EN ISO 3744; EN 500-6)	
> Sound pressure level at the operator's stations	L _{PA} ≤ 85 dB(A) (EN ISO 11201; EN 500-6)	
Fuel tank	400 litres	
Undercarriage		
Crawler tracks		
> Version	with rubber pads	
> Ground contact	3,060 x 305 mm	
> Track tension adjuster	spring assembly	
> Lubrication of track rollers	lifetime	
Traction drive	electronically controlled separate hydraulic drive provided for each crawler track	
Speeds		
> Paving	up to 25 m/min., infinitely variable	
> Travel	up to 4.5 km/h, infinitely variable	
Material hopper		
Hopper capacity	14 t	
Width	3,280 mm	
Feed height	590 mm	
Push-rollers		
> Standard	oscillating	
> Position	can be displaced forwards by 100 mm	
> Option	sprung and oscillating (PaveDock), displaceable longitudinally by 100 mm	

Conveyors and augers

Conveyors

> Version	2, with replaceable feeder bars, direction of conveyor temporarily reversible
> Drive	separate hydraulic drive provided for each conveyor
> Speed	up to 45 m/min., infinitely variable (manual or automatic)

Augers

> Version	2, with replaceable auger blades and reversible direction of rotation
> Diameter	480 mm / 420 mm / 340 mm
> Drive	separate hydraulic drive provided for each auger
> Speed	up to 80 rpm, infinitely variable (manual or automatic)
> Height	infinitely variable hydraulically up to 15 cm

Lubrication centralized lubrication system with electrically driven grease pump

Screed options	AB 500	AB 600	SB 300	SB 300 HD	SB 350
Basic width	2.55 m to 5 m	3 m to 6 m	3 m	3 m	3.5 m
Maximum width (TV/TP1/TP2)	8.75 m	9.75 m	13 m	10 m	14 m
Maximum width (TP2 Plus)	8 m	9 m	-	-	-
Compacting systems	TV, TP1, TP2, TP2 Plus	TV, TP1, TP2, TP2 Plus	TV, TP1, TP2	TV	TV, TP1, TP2

Layer thickness up to 40 cm (SB 300 / SB 350)

Screed heating

> Version	electric by heating rods*
> Power supply	three-phase AC generator

Dimensions (transport) and weights

Length

> Version	tractor unit and screed
> AB500/600	TV: 6.72 m / TP1, TP2, TP2 Plus: 6.85 m
> SB 300/350	TV, TP1, TP2: 6.57 m
> SB 300 HD	TV: 6.57 m

Weights

> Version	tractor unit and screed
> AB 500 TV	pave widths up to 5 m: 23,300 kg / pave widths up to 8.75 m: 28,700 kg

Key: DOC = Diesel Oxidation Catalyst, DPF = Diesel Particulate Filter, SCR = Selective Catalytic Reduction, AB = Extending Screed, SB = Fixed-Width Screed, HD = Heavy-Duty, TV = with tamper and vibrators, TP1 = with tamper and 1 pressure bar, TP2 = with tamper and 2 pressure bars, TP2 Plus = with special tamper, 2 pressure bars and additional weights, * not for SB 300 HD

SIDE AND FRONT VIEW

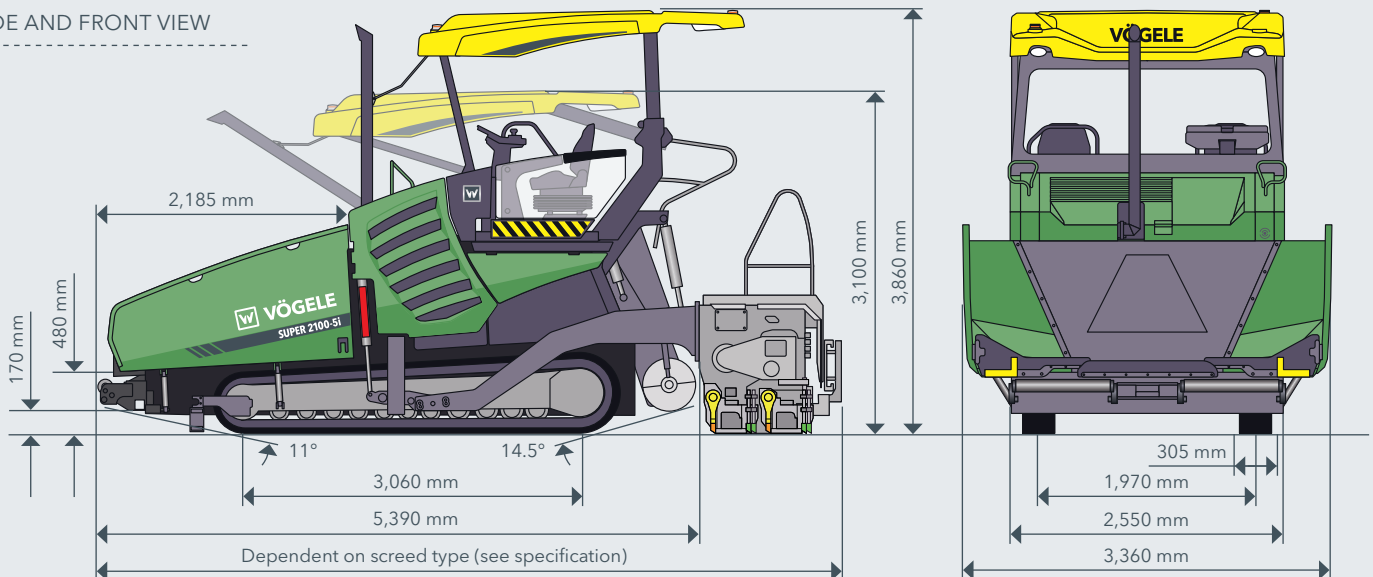

THE HIGHLIGHTS OF THE OF THE SUPER 2100-5(i)

- > Tracked paver of the latest generation with a large range of applications and pave widths up to 14 m
- > Powerful JOHN DEERE engine and thus one-stop service
- > The VÖGELE EcoPlus low-emissions package significantly reduces fuel consumption and noise emissions
- > ErgoPlus 5 - the next evolutionary step in the proven operating concept from VÖGELE
- > Equipped for the future with ErgoPlus 5 Premium Touch
- > Optimum material feed thanks to the large material hopper, the PaveDock sprung push-rollers, and the PaveDock Assistant communication
- > Greater safety and reduced set-up time at night-working job sites thanks to Light Package and Light Package Plus
- > Paver Access Control makes the paver ready for operation and transport more quickly
- > Niveltronic Plus Assist automated grade and slope control for automated roof profile and transverse profile paving
- > New generation screeds with Dual Shift Tamper for rapid tamper-stroke adjustment

FEATURES	SUPER 2100-5i	SUPER 2100-5
> Powerful oil-cooled generator	■	■
> VÖGELE EcoPlus low-emissions package	■	□
> ErgoPlus 5 paver operator's platform with fixed roof	■	■
> Paver operator's console Premium	□	□
> Windscreen with windscreen wipers	□	□
> Convenience Package für paver operator's platform	□	□
> AutoSet Plus for simple repositioning and saving of paving programs	□	□
> Light Package and Light Package Plus	□	□
> PaveDock Assistant communication system	□	□
> PaveDock sprung push-rollers	□	□
> Large receiving hopper holding 14 tonnes	■	■
> Hydraulic hopper front	□	□
> Sonic sensor to control augers	■	■
> Auger tunnel illumination	■	■
> Niveltronic Plus and Niveltronic Plus Assist for automated grade and slope	□	□
> Ventilation system	□	□
> VÖGELE RoadScan comprehensive asphalt temperature measuring system	□	□
> WITOS Paving Docu records paver and paving data	□	□
> WITOS Paving Plus process management solution	□	□
> Telematics System Operation Center	□	□

This list is just an extract of the scope of supply.
Standard features and options may differ by sales region.

■ Standard feature □ Option

JOSEPH VÖGELE AG

Joseph-Vögele-Str. 1
67075 Ludwigshafen
Germany

T: +49 621 8105-0
F: +49 621 8105-461
M: marketing@voegele.info

www.voegele.info

