

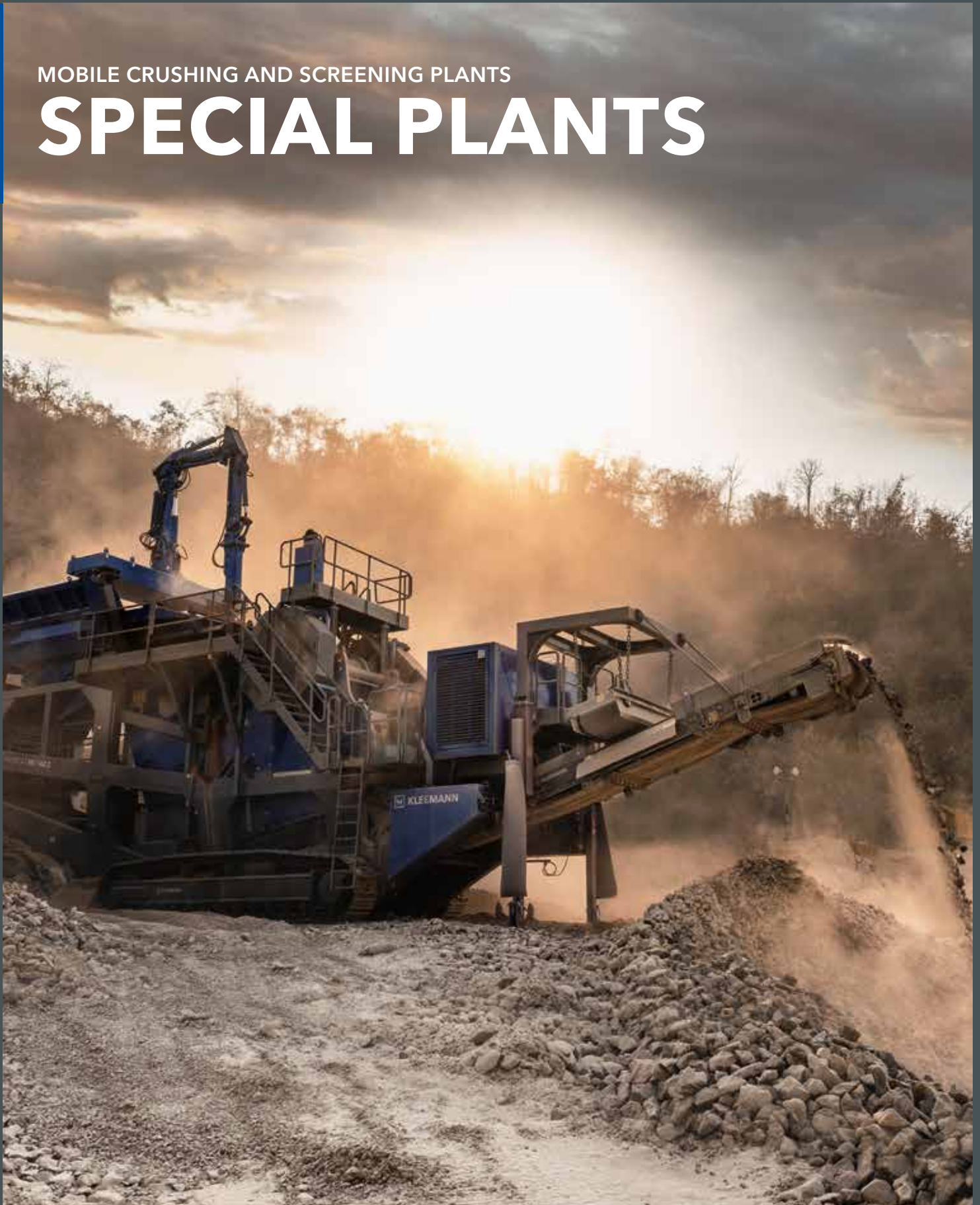

MOBILE CRUSHING AND SCREENING PLANTS

# SPECIAL PLANTS



 **KLEEMANN**

# A LONG TRADITION OF EXPERTISE.

For the past 100 years, KLEEMANN GmbH has been developing and manufacturing machines and plants for the natural stone and recycling industry.

High levels of performance and innovative details, simple handling and maximum safety for the operator - this is what KLEEMANN crushing and screening plants stand for.

**Over 100 years of**  
history

**A WIRTGEN GROUP Company**  
an internationally active group of companies



**with more than 200**  
subsidiaries and dealers at home and abroad



MOBILE  
JAW CRUSHERS



**MOBICAT**



**MOBIREX**

MOBILE  
IMPACT CRUSHERS



**MOBISCREEN**

MOBILE  
SCREENING PLANTS



**MOBICONE**

MOBILE  
CONE CRUSHERS





## THE QUARRY

Supplier of natural raw materials.

Natural rock deposits can be found in many places around the world. Quarries are an important source of raw materials which are used in our everyday lives.

A distinction is generally made between two types of quarry materials: solid rock, i.e.

natural stone, and loose rock such as sand, ballast and gravel.

Extraordinary forces and maximum plant capacity utilisation are required to process these large rock masses.

# PROCESSING ROCK AND STONE

The right solution for every requirement.

 **Up to 1200 t/h**  
for high production quantities

 **High flexibility**  
thanks to mobile plants

 **Professional planning**  
to suit the specific application

The demands made on crushing and screening plants in the quarry are special and challenging.

For processing natural stone, individual solutions are often required in order to optimally process the different material with its special features. With the experts from KLEEMANN, the various projects are professionally planned and the machines are adapted to the respective application.

## Special plants:

- Jaw and cone crushers with material compressive strengths of up to 300 MPa (depending on the crushing ratio)
- Impact crushers with material compressive strengths of up to 150 MPa (depending on the crushing ratio)
- For large to maximum batch sizes
- Solutions for use in soft, medium-hard and hard natural stone



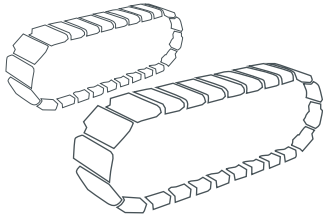

# MOBILE TECHNOLOGY

For maximum economic efficiency.

**High efficiency**  
through prescreening

**Easy to maintain**  
thanks to good accessibility

**Powerful**  
for large batch sizes



## Loading and handling costs can be significantly reduced with the mechanical treatment at the extraction site.

Compared to the stationary technology, mobile processing technology has many advantages. Depending on the demolition progress, it is ideal where fast and simple moving of the plant is required.

In large quarries, decentralised mobile processing plants can complement centralised stationary solutions (e.g. as primary crushers) or often even replace them. Mobile plants are also able to reliably process the material into the desired final grain sizes with corresponding high product quality, even in difficult material conditions. And they can do this at feed capacities of up to 1200 t/h.

In companies with stationary technology, additional production capacities can also be made available at very short notice with the help of mobile plants. The machines can be just as quickly dismantled and transported to the next site.

This is what distinguishes mobile crushers and screening plants:

### High availability guarantees versatile applications

- Flexible and rapid deployment (no long project periods)
- Simple manoeuvrability within the quarry
- Fast adaptation to changing conditions
- Short set-up times

### Efficiency throughout entire treatment process

- Diesel-electric drive concept (fuel saving + external power supply)
- High production output thanks to optimal process design, e.g. prescreening

### Easy to maintain

- Excellent accessibility for maintenance work
- Large platforms allow access to key components

### As opposed to stationary plants, mobile plants allow access to all demolition areas.

Since stationary plants sit firmly on the deposit, access to large demolition areas is often not possible or only possible with high costs and takes a long time. Mobile plants, on the other hand, can be moved directly to the quarry face or the desired demolition area, therefore allowing the mining of rock at every point in the quarry.

# MOBILE TECHNOLOGY

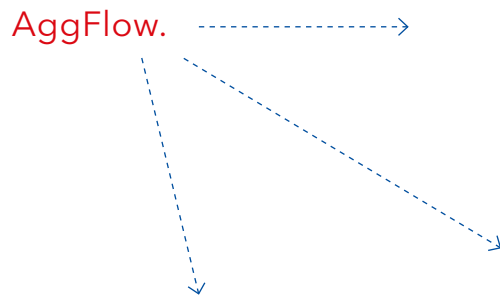

**Material streams are prepared by KLEEMANN process engineers in theoretical preliminary work.**





**With the help of AggFlow or process engineering simulations, the optimal machine combination and design can be simulated in the planning phase.**

**EXAMPLE: PROCESSING BASALT**

KLEEMANN  
MOBICAT MC 140 Z K061

KLEEMANN  
MOBICONE MCO 11 S K064-1 KX300 S/C

KLEEMANN  
MOBICONE MCO 13 K042-1 KX400 S/F

KLEEMANN  
MOBISCREEN MS 20 D K057

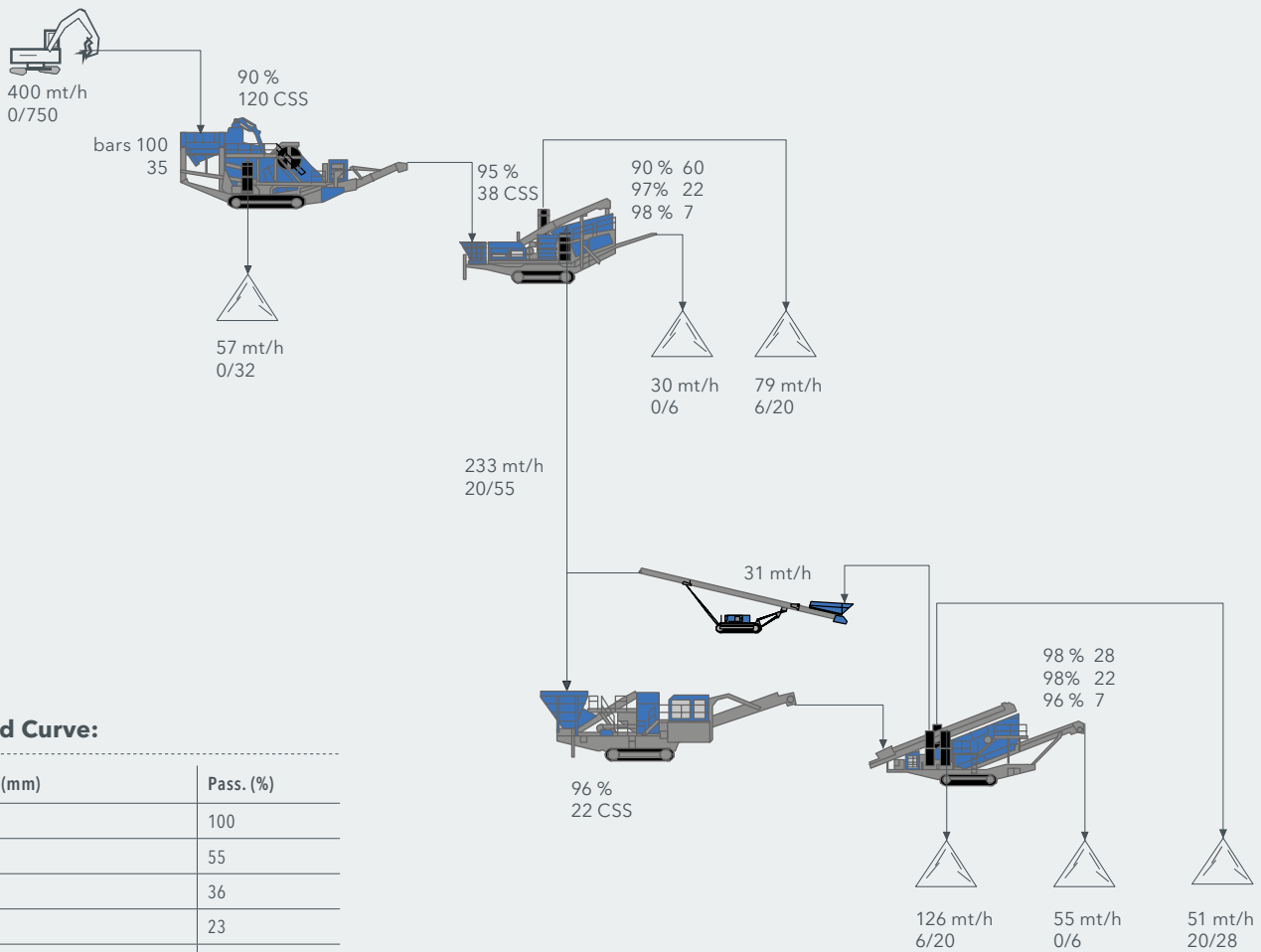

**Feed Curve:**

Size (mm)	Pass. (%)
750	100
256	55
128	36
64	23
32	15
16	9.5
8	6.5
4	4.0
2	3.0
1	2.0

Flowsheet shows peak performance, not taking into account any efficiency calculations.

**Assumed Feed Material:**

- ❑ Basalt 0-750 mm coarse
- ❑ Max. single grain dimensions 1200x750x450mm
- ❑ LA > 19
- ❑ Crushability > 35 %
- ❑ Bulk Density 1.6 t/m<sup>3</sup>



# EFFICIENT DRIVE CONCEPT

For more power.

**KLEEMANN crushing and screening plants for the quarry are equipped with efficient, powerful diesel-electric drives.**

They are optimally equipped to take on the tough demands in the quarry day after day. They can also be fitted with another electrical connection to supply power to downstream machines such as a screening plant or stockpile conveyor.

- > Efficient and powerful diesel-electric drive **A** for low fuel consumption (crusher and all conveyor belts are driven electrically)
- > External power supply **B** for even more efficient use in quarries

## KLEEMANN PROCESS KNOWLEDGE

### Protects the environment and easy on the wallet

With the diesel-electric drive concept, the crusher and all conveyor belts are driven electrically. This means that the oil lines typically found in hydraulic drives whose hoses are prone to leaks can be avoided. Lower oil quantities and longer change intervals reduce costs time, while protecting the environment.

Energy costs, exhaust emissions and noise emissions are also reduced with the option of fully electric operation.

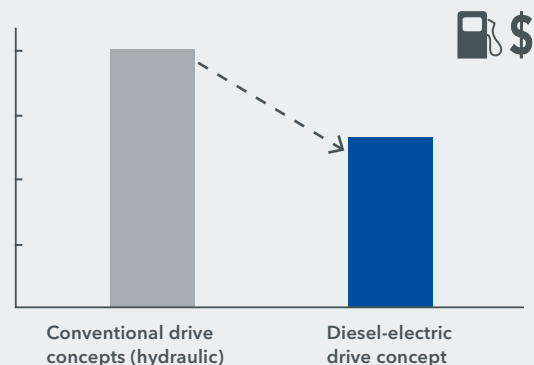

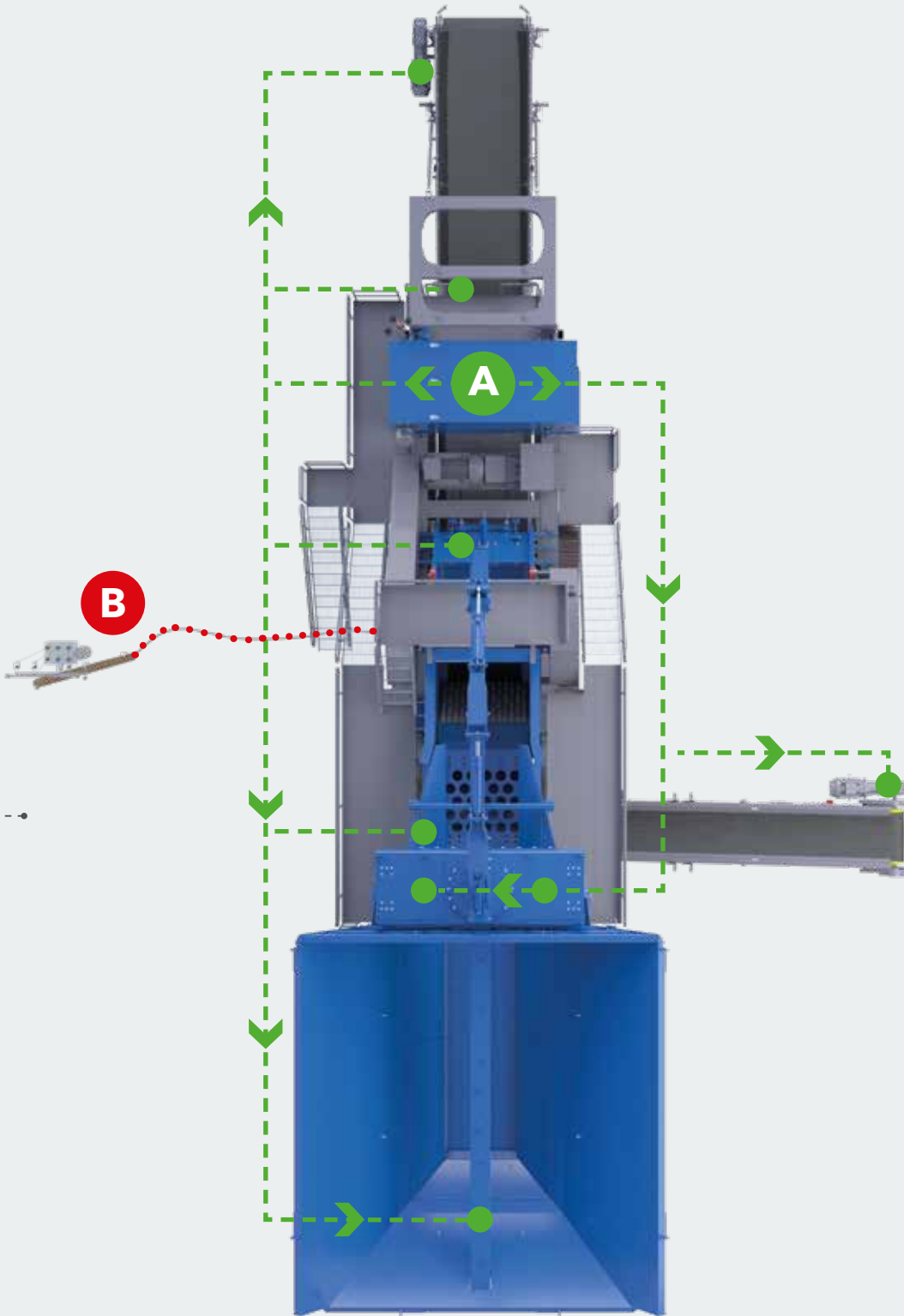

Example: MOBICAT MC 140 Z

# EFFECTIVE SCREENING

Often makes all the difference.

## The special plants from KLEEMANN are well equipped.

The plants in the MC and MR series have an active double-deck prescreen with slotted grate or perforated plate. Fines in the feed material can be screened effectively, which significantly increases the product quality.

Moreover, the feed material is largely freed of sticky or cohesive material and incrustation in the crusher or the discharge chute is prevented, therefore minimising wear.

The MCO 11 S and MCO 13 S are both equipped with a large triple-deck screen so that large material quantities can be easily screened, qualified final grain sizes can be produced and the crusher wear is reduced.





### Roll screen as prescreening

In natural stone processing, workers are confronted time and again with rocks that place special requirements on optimal processing. Individual solutions are required here. This is why many plants can be equipped with a special roll screen (instead of a double-deck prescreen) in order to screen sticky and clayey feed material thoroughly and efficiently.

The material is cleaned on the two-stage roll screen and effective separation of the fines from extremely contaminated aggregate material is achieved.

Thanks to the elliptic lifting movements of the rollers, the material is evenly distributed and also freed of cohesive elements.

Fines in the feed material fall through the rollers onto a side discharge conveyor and are effectively discharged.

Possible gap widths: up to 100 mm

#### Prescreening is responsible for:

- > Preseparating fines, which reduce the final grain quality and load the crusher unnecessarily
- > Distributing the material stream evenly in front of the crusher in layer height and width -> continuous crusher loading
- > Freeing the feed material from sticky and cohesive material -> avoiding incrustation in the crusher

# MOBICAT

## Mobile jaw crushers

The quarrying of natural stone types is associated with the use of machines that crush material with high compressive strengths systematically and effectively.

Thanks to the high quality and excellent performance of the jaw crushers from the MOBICAT series, they are ideal for tough use in quarries.

The MOBICAT plants can be equipped with numerous options such as a hopper extension, magnet, spray system and lighting.

➤ Jaw crushers are mainly used as primary crushers.

➤ Apart from the high productivity, easy maintenance also plays a decisive role.

- Low maintenance
- Quick exchange of key wear elements
- High productivity

### Optimised results with correct crusher loading:

- > The optimum filling level of the jaw crusher up to the bevelling of the crusher jaws should not be exceeded.
- > Continuous overfilling leads to premature wear, reduced service life of bearings and damage to the prescreen.
- > Continuous underfilling leads to uneven wear, a poor grain shape and reduced plant performance.
- > The maximum feed size of 90% of the feed opening should be observed.

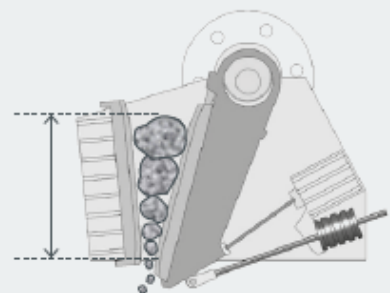

> Optimum filling level



Made for large chunks: the MC 125 Z processes pieces with an edge length of up to 1125 mm.

## MOBICAT MC 125 Z



### TECHNICAL INFORMATION

- Feed capacity: 650 t/h
- Crusher inlet: 1250 x 1000 mm
- Crusher weight: 49,000 kg
- Total weight: 130,000 kg (depending on equipment)

### PROPERTIES

- 10 m<sup>3</sup> feed hopper, hopper extension resulting in total hopper volume of up to 30 m<sup>3</sup>
- Frequency-controlled vibrating feeder
- Continuous Feed System (CFS) for continuous crusher feed
- Independently vibrating double-deck prescreen
- Diesel-electric drive concept, option of an external power supply
- Rock chisel for loosening adhering material (option)
- RR variant: with roll screen instead of prescreen, for use in cohesive material



### RECOMMENDED USE

- Processing natural stone (e.g. limestone, granite, basalt)
- Compressive strengths up to 300 MPa
- In mining applications
- For large batch sizes
- For even better results: in conjunction with the MOBICONE secondary cone crusher and a MOBISCREEN screening plant

Large feed size, impressive feed capacity, robust 54 ton crusher: high annual production volumes can be achieved with the MC 140 Z.



## MOBICAT MC 140 Z



### TECHNICAL INFORMATION

- Feed capacity: 750 t/h
- Crusher inlet: 1400 x 1130 mm
- Crusher weight: 54,000 kg
- Total weight: 160,000 kg (depending on equipment)

### PROPERTIES

- 12 m<sup>3</sup> feed hopper, hopper extension resulting in total hopper volume of up to 35 m<sup>3</sup>
- Frequency-controlled vibrating feeder
- Continuous Feed System (CFS) for continuous crusher feed
- Independently vibrating double-deck prescreen, equipped with stage for additional circulation of feed material
- Diesel-electric drive concept, option of external power supply
- Rock chisel for loosening adhering material (option)



### RECOMMENDED USE

- Processing natural stone (e.g. limestone, granite, basalt)
- Compressive strengths up to 300 MPa
- In mining applications
- For very large batch sizes
- Can be used as a single plant or as a perfectly tailored complete solution with the MOBICONE cone crusher and/or the MOBISCREEN screening plant



With a feed capacity of up to 1200 tons per hour, the MC 160 PRR is a true workaholic.



## MOBICAT MC 160 PRR



### TECHNICAL INFORMATION

- Feed capacity: 1200 t/h
- Crusher inlet: 1600 x 1250 mm
- Crusher weight: 77,000 kg
- Total weight: 400,000 kg (depending on equipment)

### PROPERTIES

- Two units: feeding unit with apron conveyor, main unit with roll screen
- Each unit has a separate crawler chassis
- Feeding with dump trucks (45 t load capacity) possible



### RECOMMENDED USE

- Processing natural stone (e.g. limestone, granite, basalt)
- Compressive strengths up to 300 MPa
- In mining applications
- For maximum batch sizes

# MOBIREX

## Mobile impact crushers

The mobile impact crushers in the MOBIREX series are used in soft to medium-hard stone. The performance of the plant systems is impressive - not just in terms of pure volume reduction. Cost and environmental awareness, availability, versatility and, above all, the quality of the end product to be produced are important aspects that speak for the MOBIREX impact crushers from KLEEMANN.

The MOBIREX impact crushers crush stone so efficiently that the grain shape, grain size distribution and cleanness comply with the strict standards for concrete and asphalt aggregates.

The MOBIREX plants can be equipped with numerous options such as a magnet, spray system and lighting.

### KLEEMANN PROCESS KNOWLEDGE

#### Optimised results with correct crusher loading:

- > The optimal fill level of the impact crusher should be guaranteed.
- > Continuous overfilling results in increased wear and can cause frequent activation of the overload protection, therefore leading to material congestion.
- > The maximum feed size of 80% of the feed opening must be observed.
- > The gap setting ratio of the impact toggles should be set correctly.

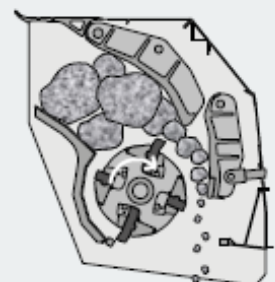

> Optimum filling



Powerful, no compromise in the design and continuously improved performance: MR 122 Z

## MOBIREX MR 122 Z



### TECHNICAL INFORMATION

- Feed capacity: 475 t/h
- Crusher inlet: 1270 x 1000 mm
- Engine power: 371 kW
- Total weight: 64,000 kg (depending on equipment)

### PROPERTIES

- Hydraulically folding feed hopper, frequency-controlled vibrating feeder
- Independently vibrating double-deck prescreen
- Crusher extractor channel
- Diesel-electric drive concept, option of external power supply
- RR variant: with roll screen instead of prescreen, for use in cohesive material



### RECOMMENDED USE

- Processing soft stone, such as limestone, in the 1st crushing stage
- Processing soft and medium-hard stone in the 2nd crushing stage
- Use in recycling
- Compressive strengths up to 150 MPa
- For medium batch sizes

Robust design and high throughput:  
the MR 150 Z with effective  
double-deck prescreen



## MOBIREX MR 150 Z



### TECHNICAL INFORMATION

- Feed capacity: 550 t/h
- Crusher inlet: 1520 x 1000 mm
- Engine power: 480 kW
- Total weight: 75,000 kg  
(depending on equipment)

### PROPERTIES

- Hydraulically folding hopper walls
- Hydraulically folding feed hopper, frequency-controlled vibrating feeder
- Independently vibrating double-deck prescreen
- Diesel-electric drive concept, option of external power supply



### RECOMMENDED USE

- Processing soft stone, such as limestone, in the 1st crushing stage
- Processing soft and medium-hard stone in the 2nd crushing stage
- Use in recycling
- Compressive strengths up to 150 MPa
- For large batch sizes



The MR 170 Z is optimally adapted to the needs of its user and ideal for longer term use.

## MOBIREX MR 170 Z



### TECHNICAL INFORMATION

- ✔ Feed capacity: 700 t/h
- ✔ Crusher inlet: 1660 x 1000 mm
- ✔ Engine power: 480 kW
- ✔ Total weight: 93,000 kg (depending on equipment)

### PROPERTIES

- ✔ Hydraulically folding hopper walls
- ✔ Hydraulically folding feed hopper, frequency-controlled vibrating feeder
- ✔ Independently vibrating double-deck prescreen
- ✔ Diesel-electric drive concept
- ✔ Feed size up to max. 1300 x 800 mm



### RECOMMENDED USE

- ✔ Processing soft stone, such as limestone, in 1st crushing stage
- ✔ Processing soft and medium-hard stone in the 2nd crushing stage
- ✔ Compressive strengths up to 150 MPa
- ✔ For large batch sizes

# MOBICONE

## Mobile cone crushers

The MOBICONE mobile cone crushers are used in medium-hard to hard, as well as abrasive natural stone, and in mining applications.

The cone crushers delivery top-quality cubic final grain sizes in the 2nd and 3rd crushing stages. The MOBICONE plants are available in different sizes and versions and for various applications.

Numerous equipment options such as a magnetic remover or metal detector, camera monitoring at the crusher, as well as a spray system and lighting, are available.

They really demonstrate their strengths in connection with the MOBICAT jaw crushers and the screening plants from the MOBISCREEN series.

### KLEEMANN PROCESS KNOWLEDGE

#### Material flow MCO 11 S/MCO 13 S

- > The material is fed to the hopper from where the material is transported to the screening unit via the feeding conveyor. Then prescreening takes place in the triple-deck screening unit (2). The oversize grain in the upper deck is fed directly to the cone crusher and back to the feed hopper via the return conveyor (3). Then another screening and/or crushing cycle will start.
- > The screen overpass in the middle and lower decks falls onto a side discharge conveyor and is transported onto a stockpile (4).
- > Fines which pass through the entire screening unit are taken away via the wide fine grain conveyor (5).

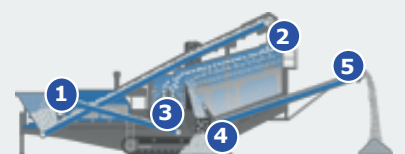



Robust and reliable - the MCO 11 S with highly effective triple-deck screening unit.

## MOBICONE MCO 11 S



### TECHNICAL INFORMATION

- Feed capacity: 450 t/h
- Crusher system size:  $d=1120$  mm
- Max. feed size: 200 mm
- Screen size (W x L): 2050 x 5455 mm
- Weight: 75,000 kg  
(depending on equipment)

### PROPERTIES

- Closed material loop for production of three defined final grain sizes with highly effective triple-deck classifying screen
- Diesel-electric drive concept, option of external power supply
- Option to connect with with other KLEEMANN plants



### RECOMMENDED USE

- Secondary and tertiary crushing (mainly) of medium-hard to hard, as well as abrasive natural stone
- In mining applications
- Compressive strengths up to 300 MPa
- For large batch sizes

For maximum feed sizes of  
up to 330 mm - the MCO 13.



## MOBICONE MCO 13



### TECHNICAL INFORMATION

- Feed capacity: 590 t/h
- Crusher system size:  $d=1320$  mm
- Max. feed size: 330 mm
- Weight: 76,000 kg  
(depending on equipment)

### PROPERTIES

- Cone crusher with bearings and automatic circulation lubrication for high output and long service life
- Diesel-electric drive concept, option of external power supply
- Option to connect with other KLEEMANN plants



### RECOMMENDED USE

- Secondary and tertiary crushing (mainly) of medium-hard to hard, as well as abrasive natural stone
- In mining applications
- Compressive strengths up to 300 MPa
- For very high hourly output



With its generously dimensioned triple-deck screening unit, the MCO 13 S is designed for large quantities of material.



## MOBICONE MCO 13 S



### TECHNICAL INFORMATION

- Feed capacity: 650 t/h
- Crusher system size:  $d=1320$  mm
- Max. feed size: 280 mm
- Screen size (W x L): 2350 x 6600 mm
- Weight: 115,000 kg  
(depending on equipment)

### PROPERTIES

- Closed material loop for production of three defined final grain sizes with triple-deck classifying screen
- Diesel-electric drive concept, option of external power supply
- Option to connect with other KLEEMANN plants



### RECOMMENDED USE

- Secondary and tertiary crushing (mainly) of medium-hard to hard, as well as abrasive natural stone
- In mining applications
- Compressive strengths up to 300 MPa
- For very high hourly output

# MOBISCREEN

## Mobile screening plants

The MS 20 D and MS 23 D mobile screening plants are designed so that they meet the tough conditions in everyday use in the quarry. Their efficient diesel-electric drives make them productive and ideal for connecting with crushing plants from KLEEMANN.

Thanks to their large screening surfaces, high throughput is also guaranteed with small final grain sizes. With the use of a classifying screen, the crushing and screening process can be designed even more efficiently.

In order to achieve a high-quality end product, the screening plant should be individually adapted to the application.

The MS 20 D and MS 23 D mobile screening plants are fed either from an upstream crusher or a corresponding stockpile conveyor.

In order to achieve optimal utilisation of the screening surface and excellent productivity results, it is necessary to ensure continuous feeding here.

### Highly effective screening

The two MS 20 D and MS 23 D special plants are equipped with a banana screen, which is up to 10% more effective than conventional screening units. The screen surface resembles the shape of a banana.

The upper part is relatively steep, flat at the bottom and then goes into a slight incline again. The material remains on the screening surface longer and is screened more systematically and effectively. This screen type is used at high power.

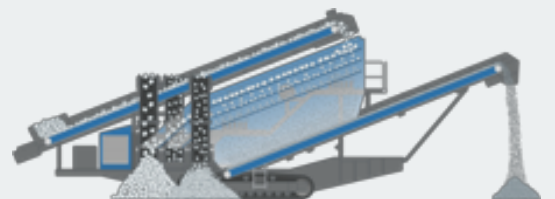

The mobile classifying screens  
for up to 4 final grain sizes.



## MOBISCREEN MS 20 D



### TECHNICAL INFORMATION

- Feed capacity: 650 t/h
- Screen size (W x L): 2050 x 6000 mm
- Engine power: 226 kW
- Weight: 56,000 kg  
(depending on equipment)

### PROPERTIES

- Mobile triple-deck screening unit
- Diesel-electric drive concept, option of external power supply
- Spray system and lighting available as optional equipment
- Maximum feed size 100 x 160 mm



### RECOMMENDED USE

- In natural stone applications
- For large batch sizes
- For a complete process: can be combined with KLEEMANN crushing plants

The MOBISCREEN MS 23 D stands out with its highly effective triple-deck screening unit with twin-shaft drive.



## MOBISCREEN MS 23 D



### TECHNICAL INFORMATION

- Feed capacity up to approx. 800 t/h
- Screen size (W x L): 2300 x 8000 mm
- Engine power: 226 kW
- Weight: 93,000 kg (depending on equipment)

### PROPERTIES

- Mobile triple-deck screening unit with twin-shaft drive
- Diesel-electric drive concept, option of external power supply
- Spray system and lighting available as optional equipment
- Maximum feed size 100 x 160 mm



### RECOMMENDED USE

- In natural stone applications
- For maximum batch sizes
- For a complete process: can be combined with KLEEMANN crushing plants



**01** MC 140 Z in Thailand

**02** MCO 11 S in Sweden

**03** Granite quarry in Germany

**04** MS 20 D in Ireland

**05** MR 122 Z in USA

**06** MC 140 in Ireland

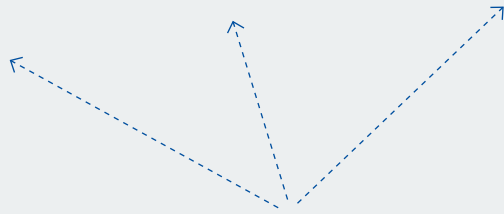

## BROUGHT INTO LINE

For perfect combination versatility.

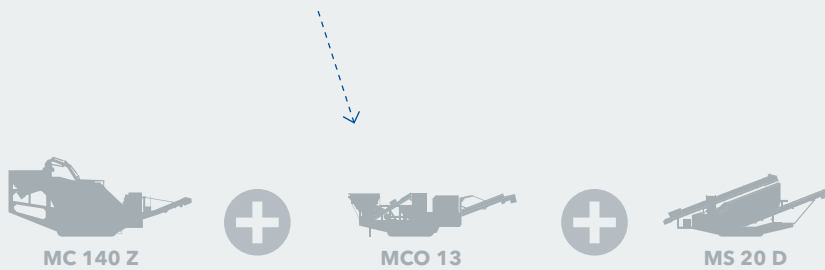

### Technical expertise.

The line coupling option allows special Kleemann plants to be coupled with one another. The crushing process between the crushing plants is automatically controlled so that material is always conveyed with maximum efficiency through the machines.

A probe is installed at the crusher discharge conveyor of the upstream machine, which monitors the filling level of the feeding unit of the downstream machine. When the filling level reaches a defined height, the output of the upstream plant is temporarily reduced or feeding is switched off, therefore effectively reducing the overfilling of individual machines and ensuring that machine utilisation is always ideal.

For safety reasons, the crushing and screening plants are connected physically with each other by a cable. If an emergency stop button is pressed on the plant train in the event of an emergency, all machines are safely stopped.



Depending on the end product, various plant combinations are suitable for the production of standard grain sizes.



# YOUR KLEEMANN SERVICE

From the WIRTGEN GROUP.

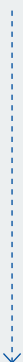

**Reduced downtimes, minimal wear costs,  
maximum customer proximity.**



## Service network

Our local contact partners provide you with comprehensive support for all applications and questions related to our products. Thanks to our closely-knit, global WIRTGEN GROUP network, we guarantee short response times and quick solutions.

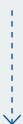

## Training courses

An essential element of the successful use of our plants is knowledge of their operation. In order to communicate the necessary technical knowledge to your employees, KLEEMANN offers a wide range of training courses.



## Parts and accessories

Original parts and accessories from KLEEMANN can assure the high reliability and availability of the machines in the long term. An overview of all parts is available at [www.partsandmore.net](http://www.partsandmore.net)







## MOBICAT



### MC 125 Z

Feed size up to max. (depending on material)	1125 x 700 mm
Crusher inlet (W x H)	1250 x 1000 mm
Feed capacity up to approx.	650 t/h
Weight* approx.	130,000 kg



### MC 140 Z

Feed size up to max. (depending on material)	1260 x 790 mm
Crusher inlet (W x H)	1400 x 1130 mm
Feed capacity up to approx.	750 t/h
Weight* approx.	160,000 kg



### MC 160 PRR

Feed size up to max. (depending on material)	1440 x 900 mm
Crusher inlet (W x H)	1600 x 1250 mm
Feed capacity up to approx.	1200 t/h
Weight* approx.	400,000 kg

## MOBICONE

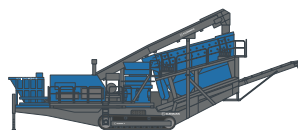

### MCO 11 S

Feed size up to max. (depending on material)	200 mm
Crusher system size: d=	1120 mm
Feed capacity up to approx.	450 t/h <sup>1)</sup>
Weight* approx.	75,000 kg



### MCO 13

Feed size up to max. (depending on material)	330 mm
Crusher system size: d=	1320 mm
Feed capacity up to approx.	590 t/h
Weight* approx.	76,000 kg

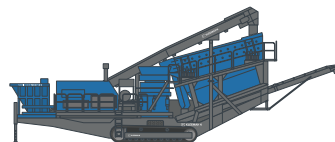

### MCO 13 S

Feed size up to max. (depending on material)	280 mm
Crusher system size: d=	1320 mm
Feed capacity up to approx.	650 t/h <sup>1)</sup>
Weight* approx.	115,000 kg

## MOBIREX



### MR 122 Z

Feed size up to max. (depending on material)	1000 x 625 mm
Crusher inlet (W x H)	1270 x 1000 mm
Feed capacity up to approx.	475 t/h
Weight* approx.	64,000 kg

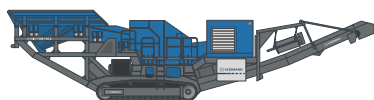

### MR 150 Z

Feed size up to max. (depending on material)	1220 x 760 mm
Crusher inlet (W x H)	1520 x 1000 mm
Feed capacity up to approx.	550 t/h
Weight* approx.	75,000 kg



### MC 170 Z

Feed size up to max. (depending on material)	1380 x 830 mm
Crusher inlet (W x H)	1660 x 1000 mm
Feed capacity up to approx.	700 t/h
Weight* approx.	93,000 kg

## MOBISCREEN

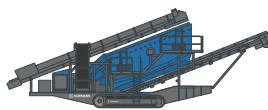

### MS 20 D

Type	Triple-deck screening plant
Classification of	up to 4 fractions
Screen decks	3
Screen casing size (W x D)	2050 x 6000 mm
Feed capacity up to approx.	650 t/h
Feed size up to max.	100 x 160 mm
Weight* approx.	56,000 kg

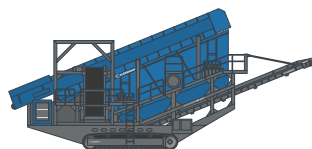

### MS 23 D

Type	Triple-deck screening plant
Classification of	up to 4 fractions
Screen decks	3
Screen casing size (W x D)	2300 x 8000 mm
Feed capacity up to approx.	800 t/h
Feed size up to max.	100 x 160 mm
Weight* approx.	93,000 kg

\* Minimum weight without options, exact weight specifications upon request

1) closed circuit



**KLEEMANN GmbH**

Germany

Manfred-Wörner-Str. 160  
73037 Göppingen

Tel.: +49 7161 206-0

E-mail: [info@kleemann.info](mailto:info@kleemann.info)

 [www.kleemann.info](http://www.kleemann.info)